

# Perry Nuclear Power Plant (PNPP)

License Renewal (60 Year) Application Pre-Submittal Meeting

# Opening Remarks and Introductions

---

## Opening Remarks

- NRC
- Energy Harbor

## Speakers

- Mark Bensi (Energy Harbor, LR Team, Project Manager)
- Theodore Hilston (Energy Harbor, LR Team, Technical Lead)

## Participants

- Douglas Reeves (Energy Harbor, Director of Site Engineering, Project Sponsor)
- Paul Roney (Energy Harbor, LR Team, Mechanical)
- Mohammed Alvi (Energy Harbor, LR Team, Structural)
- Barry Schneidman (Energy Harbor, LR Team, Mechanical)
- George Kyle (Energy Harbor, LR Team, Electrical)
- Benjamin Spiesman (Energy Harbor, LR Team, ER/SAMA and OE)
- Stuart Thickman (Energy Harbor, LR Team, TLAA)
- Steven Dort (Energy Harbor, LR Team, LRA Author)
- Justin Truxall (Energy Harbor, AMP implementation Coordinator)
- Ryan Lighty (Morgan Lewis, Legal Support)

# Agenda

---

- Background
- General Plant Information
- Application Preparation Approach
  - Scoping and Screening
  - Aging Management Review (AMR)
  - Aging Management Program (AMPs)
  - Time-Limited Aging Analyses (TLAA)
  - Operating Experience
- Topics of Interest/Unique PNPP Aspects
  - PNPP Unit 2 impact on LR
  - PNPP Property Boundaries
  - PNPP Flooding LAR
  - Pre-PEO LR implementation
- Schedule and Closing Remarks
- Questions and Answers

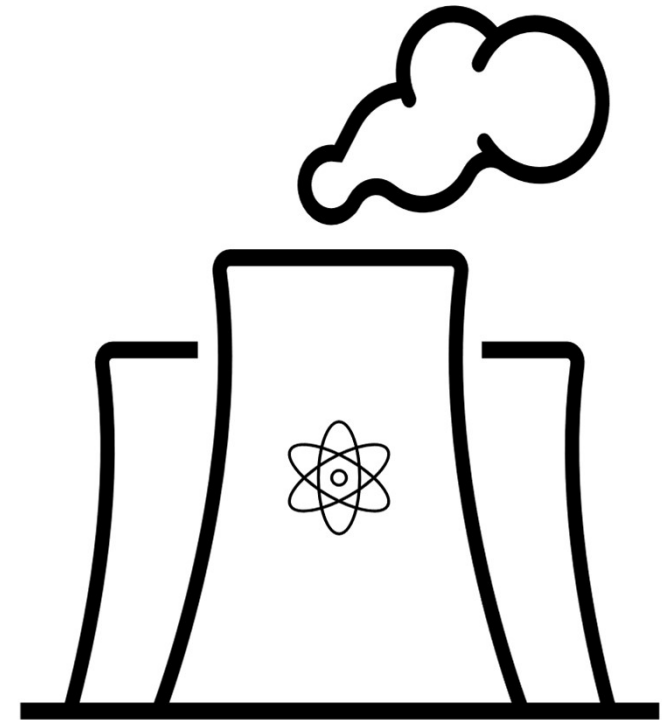

# Background

---

## Energy Harbor Nuclear Corp.

- In March of 2020, the Perry Nuclear Power Plant (PNPP) staff implemented License Amendment 187 that revised the Operating License to reflect a direct transfer of operating authority for the facility from FirstEnergy Nuclear Operating Company (FENOC) to Energy Harbor Nuclear Corp. (EHNC), a direct transfer of ownership of the facility from FirstEnergy Nuclear Generation, LLC (FENGen) to Energy Harbor Nuclear Generation LLC and an indirect transfer of ownership of the facility to Energy Harbor Corp.

## Perry's License Renewal Application

- Perry's current operating license expires at midnight on 11/07/2026.
- Perry was granted an exemption from specific requirements of Title 10 of the *Code of Federal Regulations* (10 CFR), 10 CFR 54.17(a)'s requirement that an application for a renewed license be in accordance with Subpart A of 10 CFR Part 2, and, more specifically, 10 CFR 2.109(b). Section 2.109(b) provides timely renewal protection to licensees that submit sufficient license renewal applications at least five years before the expiration of the existing license. Thus, this exemption allows EHNC to submit a license renewal application for PNPP at least three years prior to the expiration of its existing license and, if the application is sufficient, to still receive timely renewal protection.

# General Plant Information

---

## Perry Nuclear Power Plant, PNPP Unit 1

- General Electric BWR-6, Mark III Containment
- Located in northeast Ohio, 35 miles northeast of Cleveland
- Current rated core thermal power of 3,758 MWt
  - Original licensed core thermal power of 3,579 MWt
  - Power Uprate completed in 2000 (Amendment 112, 105% Uprate)
- Current gross electrical output of 1,327.6 MWe, net output of 1,277 MWe
- Plant Operating License issued 11/13/1986

## Perry Nuclear Power Plant, PNPP Unit 2

- Intended to be nearly identical to Unit 1
- Some PNPP structures originally intended to serve as common between both units
- Construction activities formally terminated in 1994
- Some Unit 2 Structures, Systems and Components (SSCs) support Unit 1 operation
  - Some Unit 2 SSCs therefore in Unit 1 LR scope

# General Plant Information

## Major Plant Structures

1. Unit 1 Reactor Building
2. Unit 2 Reactor Building
3. Unit 1 Turbine Building
4. Unit 2 Turbine Building
5. Control Complex
6. Diesel Generator Building
7. Unit 1 Off-Gas Building
8. Unit 1 Turbine Power Complex
9. RadWaste Building
10. Emergency Service Water Pumphouse
11. Service Water Pumphouse
12. Water Treatment Building
13. Lake Erie (UHS)
14. Switchyard
15. Unit 2 Heater Bay

### Not visible in image

- Unit 1 Auxiliary Building
- Unit 2 Auxiliary Building
- Intermediate Building
- Fuel Handling Building
- Unit 2 Turbine Power Complex
- Unit 1 Heater Bay
- Unit 2 Off-Gas Building



# License Renewal Application Approach

---

## Regulatory Guidance

- The License Renewal Application format and content is based on:
  - NUREG 1800 “Standard Review Plan for Review of License Renewal Applications for Nuclear Power Plants,” Revision 2
  - NUREG 1801 “Generic Aging Lessons Learned (GALL) Report,” Revision 2;
  - Regulatory Guide 1.188 “Standard Format and Content for Applications to Renew Nuclear Power Plant Operating Licenses” Revision 2.

## Perry’s First License Renewal Application

- This License Renewal Application is limited to the first 20-year period of extended operation and does not address operation beyond 60 years.
  - Regulatory guidance that addresses subsequent license renewal is considered from the perspective of operating experience.

# LR Scoping and Screening

- Nuclear Safety Related Structures, Systems and Components, *10CFR54.4(a)(1)*
- Non-Safety Related Structures, Systems and Components whose failure could affect Safety-Related SSCs, *10CFR54.4(a)(2)*
- NRC Regulated Events, *10CFR54.4(a)(3)*
  - Fire Protection (10CFR50.48)
  - Environmental Qualification (10CFR50.49)
  - Pressurized Thermal Shock (10CFR50.61)
    - Not applicable to PNPP
  - Anticipated Transient Without Scram (10CFR50.62)
  - Station Black Out (10CFR50.63)

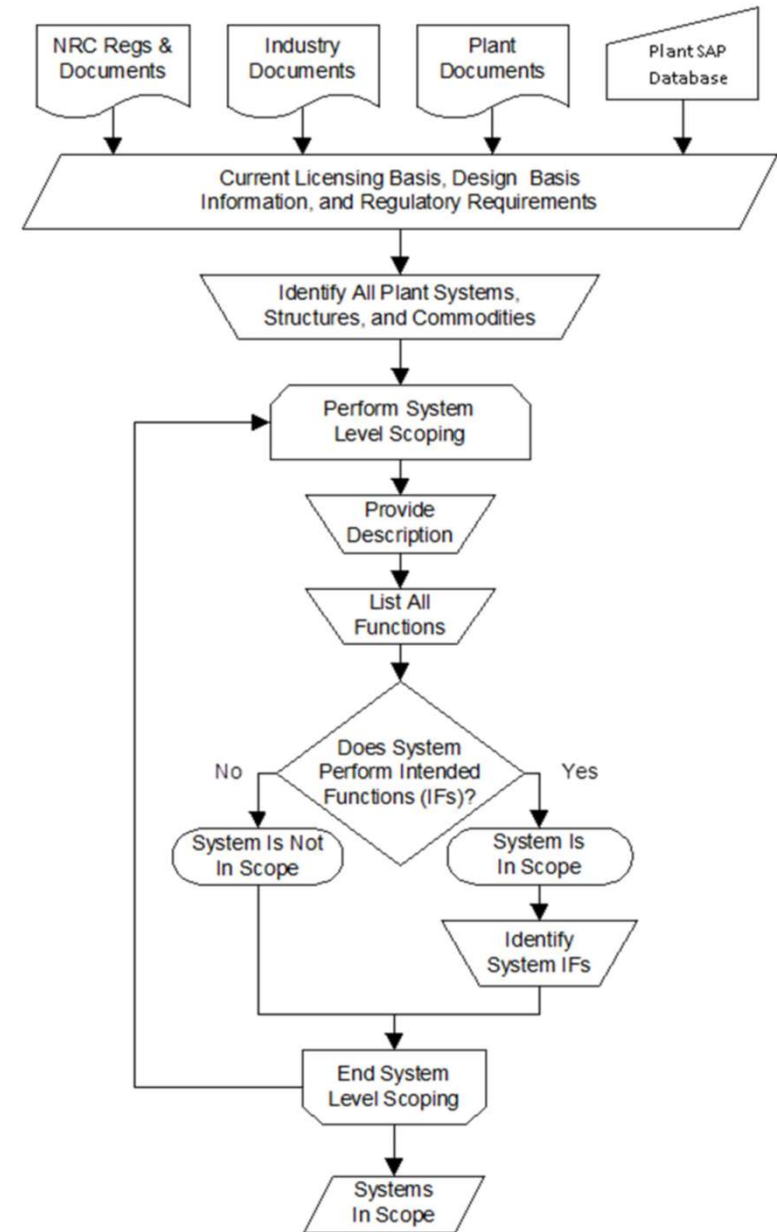



# LR Scoping and Screening

Credited by CLB for performing an intended function per 10CFR54.4(a)(1), (a)(2) or (a)(3)

In scope for 10CFR54.4(a)(2) spatial concerns, not credited in CLB

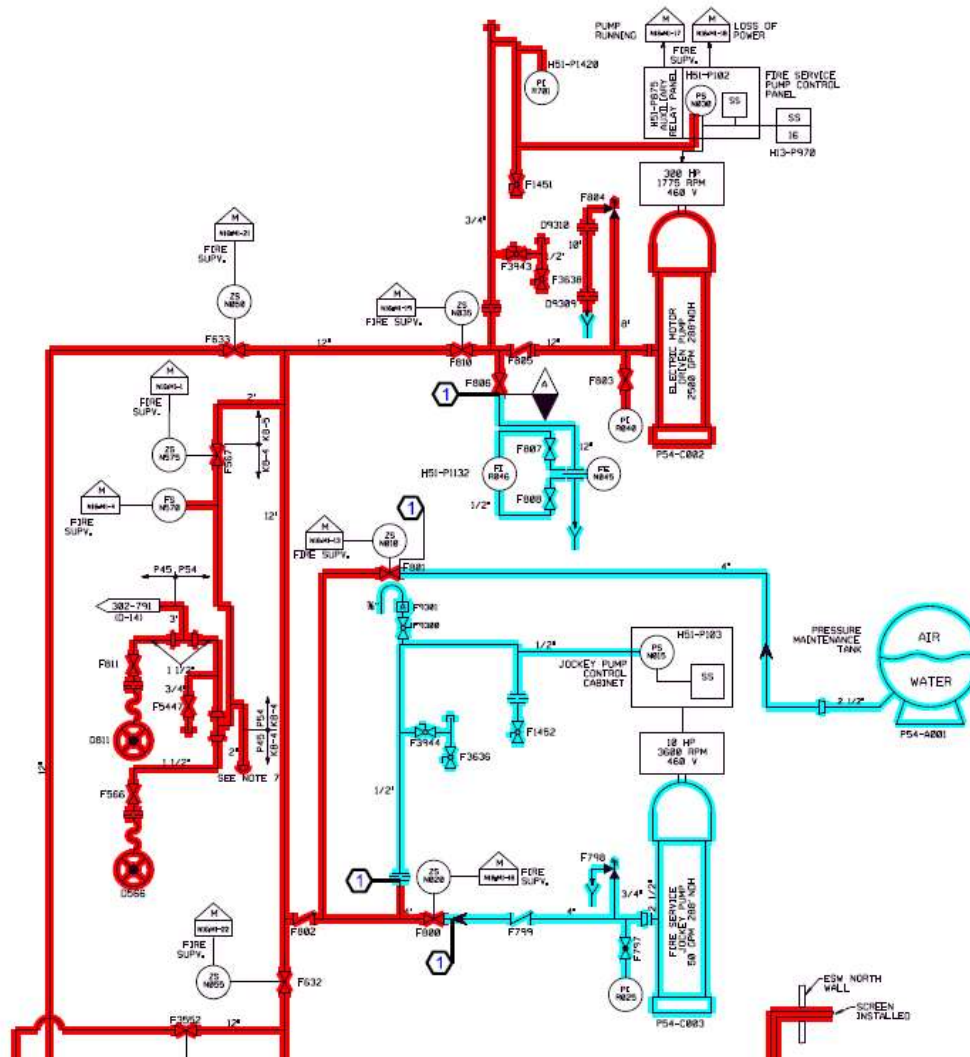

Example (Partial) of Mechanical Scoping Drawing

# Aging Management Reviews

---

## AMR Process Highlights

- Identification of Component Materials
- Identification of Component Operating Environments
- Aging Management Review
  - Identification of Potential Aging Effects
  - Identification of Aging Effects Requiring Management
  - Review of Operating and Maintenance History
  - Identification of Aging Management Programs
- Comparison of Aging Management Review Results with the GALL Report
- Results documented consistent with NEI 95-10 (9-column tables)
  - Generic Notes document level of consistency with NUREG-1801

Component Type	Intended Function(s)	Material	Environment	Aging Effect Requiring Management	Aging Management Program	NUREG-1801 Item	Table 1 Item	Notes

# Aging Management Programs

---

## AMPs Applicable to PNPP<sup>(1)</sup>

- PNPP will have 43 AMPs
  - 32 are existing programs
  - 13 existing programs will be enhanced for LR purposes
  - 11 new programs
  - No programs will contain exceptions to NUREG-1801
  - No site-specific AMPs

## AMPs Not Applicable to PNPP <sup>(1)</sup> (PWR-Specific AMPs not listed)

- X.S1, Concrete Containment Tendon Prestress
- XI.M12, Thermal Aging Embrittlement of Cast Austenitic Stainless Steel (CASS)
- XI.M22, Boraflex Monitoring
- XI.M25, BWR Reactor Water Cleanup System
- XI.S5, Masonry Walls
- XI.E4, Metal Enclosed Bus

(1) – Preliminary Information

# TLAA and Exemptions Identification

---

## Assessment Method

- Keyword search of selected licensing documents to identify potential TLAA's
  - Updated Safety Analysis Report (USAR)
  - Facility Operating License
  - NRC Safety Evaluation Reports (SERs)
  - 10 CFR 50.12 Exemption Requests
  - EPRI BWRVIP documents (incorporated by reference in the CLB)
- Comparison of the identified potential TLAA's to the TLAA's in industry documents
  - NUREG-1800, Rev. 2
  - NUREG-1801, Rev. 2
  - NEI 95-10, Rev. 6
  - Electric Power Research Institute (EPRI) Report TR-105090
- Comparison of identified potential TLAA's to other LR applicants
- Review of current exemptions to identify potential TLAA's involved with these exemptions
- Review of BWRVIP documents referenced in the PNPP BWRVIP implementing procedure

## Evaluation Method

- Verify TLAA is valid for Period of Extended Operation
- Verify TLAA can be projected through Period of Extended Operation
- Verify aging effects evaluated in the TLAA will be adequately managed through Period of Extended Operation

# Operating Experience

---

## Industry (External) OE Review

- Review period from GALL Rev. 2 issuance (December 2010 to January 2023)
- Includes generic communications such as Bulletins and Information Notices
- Ensures aging effects not identified in industry guidance documents are addressed by PNPP AMPs
- Will incorporate Nuclear Energy Institute (NEI) License renewal Task Force (LRTF) Working Group External OE results

## Site (Internal) OE Review (Condition Reports)

- Review ten-year period of January 2013 through January 2023
- Searches performed in EHNC CAP database (DevonWay)
- Provides representative set of plant-specific instances of age-related degradation
- 262 keywords used in extensive OE search
- Approx. 27,000 results from this search, approx. 6% relevant to LR

## Additional OE Information

- GALL-SLR and SLR-ISGs to be considered as Operating Experience
- Lessons learned from RAIs/RCIs and supplements to be incorporated into AMRs and AMPs

# PNPP Topics of Interest

## PNPP Unit 2

- Unit 2 construction formally terminated in 1994
- All Unit 2 structures and many systems and components completed
- Some Unit 2 SSCs support Unit 1 operation
- Some Unit 2 SSCs therefore in scope for PNPP Unit 1 LRA
  - Examples include portions of the Unit 2 Shield Building wall which serves as the wall for the Fuel Handling and Intermediate Buildings; Unit 2 Turbine Power Complex houses active equipment
- Previous initiatives have been implemented to positively delineate boundaries between active and abandoned/retired Unit 2 equipment

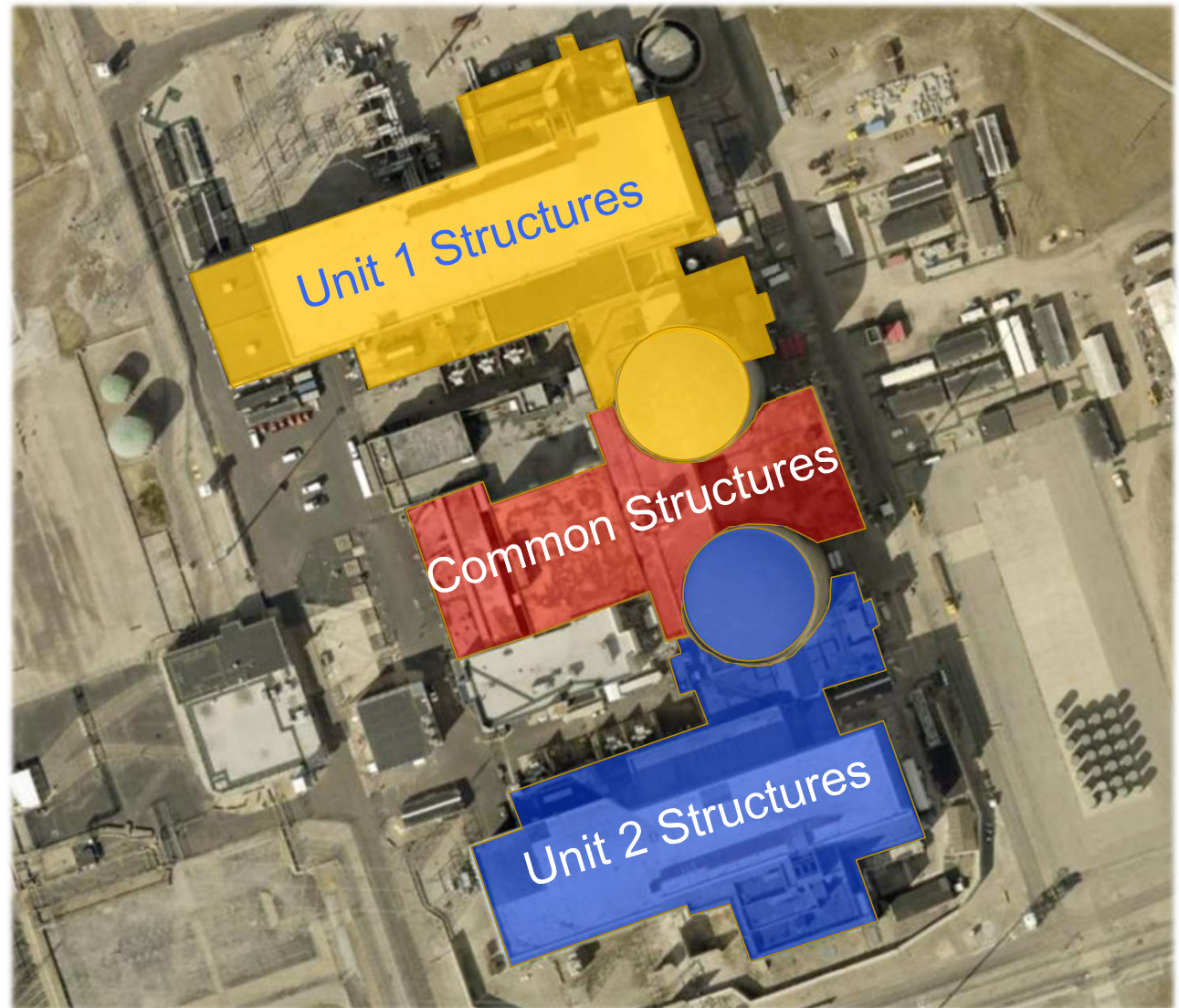

# PNPP Topics of Interest

## PNPP Property

- PNPP situated on approx. 1030 acres in NE Ohio
- All property previously owned by subsidiaries of previous parent company (FE)
- Several parcels retained by FE during Energy Harbor separation
  - PNPP Switchyard
  - Quincy Substation
  - Southwest area
- Energy Harbor working to reacquire southwest area and establish easements on switchyard and Quincy
- Expected to be resolved prior to PNPP LRA submittal
- Small parcel at southern boundary claimed under eminent domain
  - Easement being pursued, also on track for resolution



# PNPP Topics of Interest

## Flooding License Amendment Request

- In April 2021, PNPP submitted a License Amendment Request (LAR) reconstituting the site's external flood hazard design basis
- Five major aspects of the LAR
  - Methodology change for Local Intense Precipitation (LIP) domain (utilizing FLO-2D Pro computer program)
  - Use of Incorporated Barriers (as defined in RG 1.102) for mitigation of LIP effects
  - Use of deployable Incorporated Barriers (involves new Tech. Spec 3.7.11)
  - 50.12 Exemption for use of Non-Safety Related barriers
  - 50.12 Exemption for use of Non-Safety Related storm drain system
- Expected approval in Nov. 2022
  - LRA based on scope of LAR

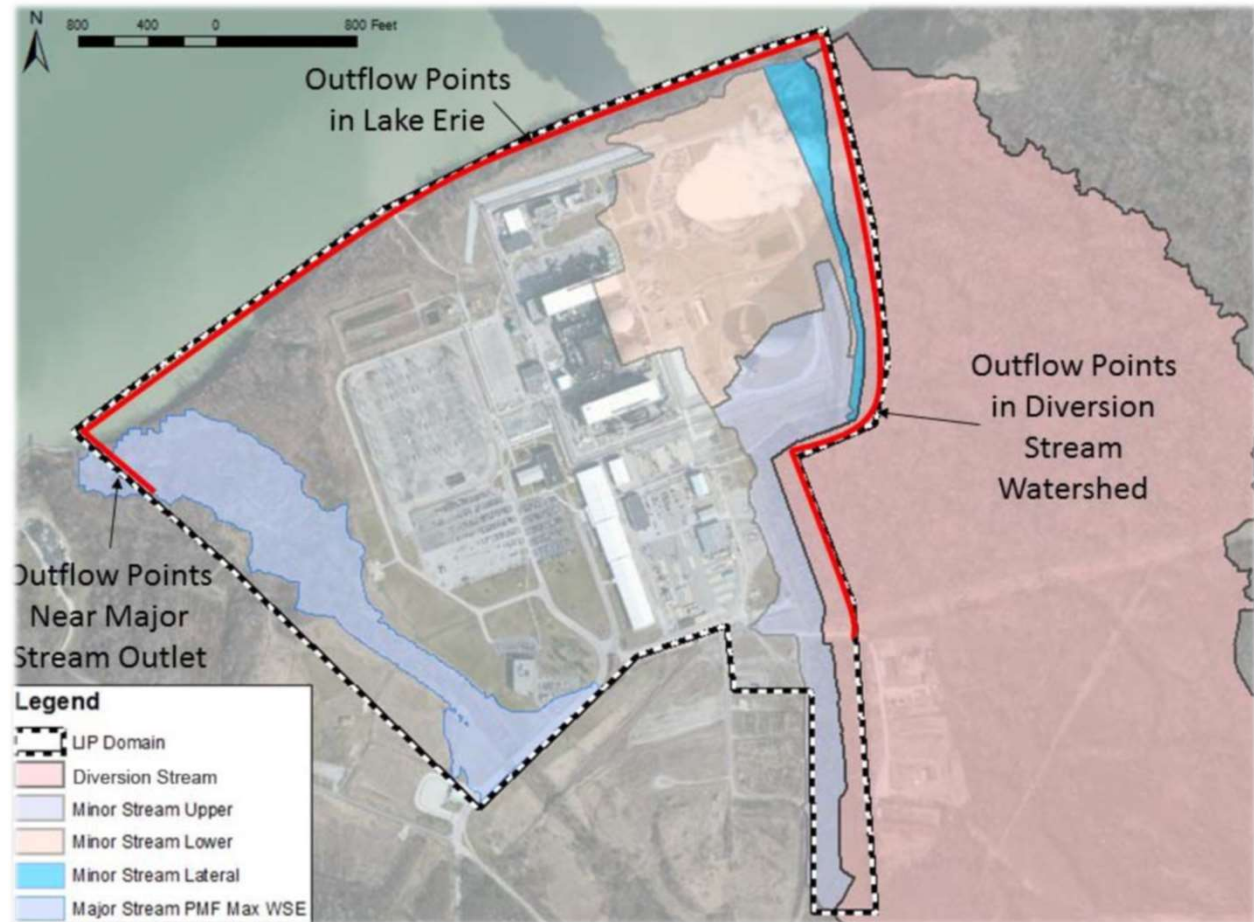



# PNPP Topics of Interest

---

## Pre-PEO Implementation Activities

- PNPP has a truncated Pre-PEO period due to the License Renewal Application (LRA) submittal date (July 2023) and license expiration (November 2026)
  - Requires LR Implementation activities in parallel with LR Application development
- One-Time Inspections
  - 39 of 203 Pre-PEO one-time inspections complete to date, more scheduled by end of year
  - PNPP will use the remaining two refueling outages to complete inspections
    - 1R19 in 2023, 1R20 in 2025
  - Approx. 50% of one-time inspections to be complete by end of the next refueling outage (1R19), with the remainder complete by end of the following refueling outage (1R20)
    - One-time Class 1 small bore piping inspections to be performed in 1R19
    - Portion of bolting integrity exams to be performed in 1R19
- AMP Program Owners identified; majority trained

# Scheduling and Closing Remarks

---

- PNPP is on track to submit the License Renewal Application in July 2023
- PNPP plans for the second Pre-Submittal Meeting in January 2023
- PNPP will submit a high-quality application which will support efficient Staff reviews
  - Highly knowledgeable team with significant LR experience
  - Participation in industry working groups and meetings
  - Industry Peer Reviews of LRA
  - Monitoring on-going applicant processes
  - Reviews of recent applicant RAIs, RCIs and Supplements
- PNPP's License Renewal Application will be consistent with NRC requirements for initial LRA, industry practices and recent precedent

# Questions and Answers

---

