

# SCALE/MELCOR Non-LWR Source Term Demonstration Project – High-Temperature Gas-Cooled Reactor

July 2021



# U.S. NRC

 **OAK RIDGE**  
National Laboratory



**Sandia**  
National  
Laboratories

# Outline

NRC strategy for non-LWR source term analysis

Project scope

High-temperature gas-cooled reactor fission product inventory/decay heat methods and results

High-temperature gas-cooled reactor plant model and source term analysis

Summary

Appendices

- SCALE overview
- VSOP
- ORIGEN library interpolation
- MELCOR overview
- MELCOR default radionuclide classes

# Integrated Action Plan (IAP) for Advanced Reactors

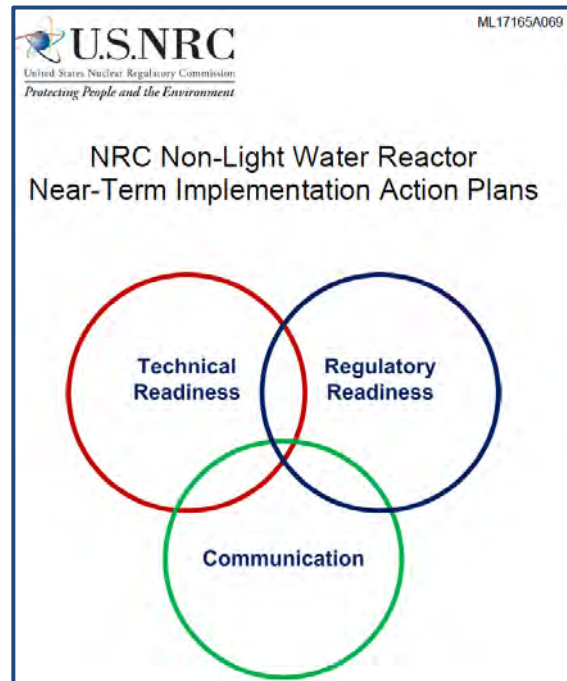

[ML17165A069](#)

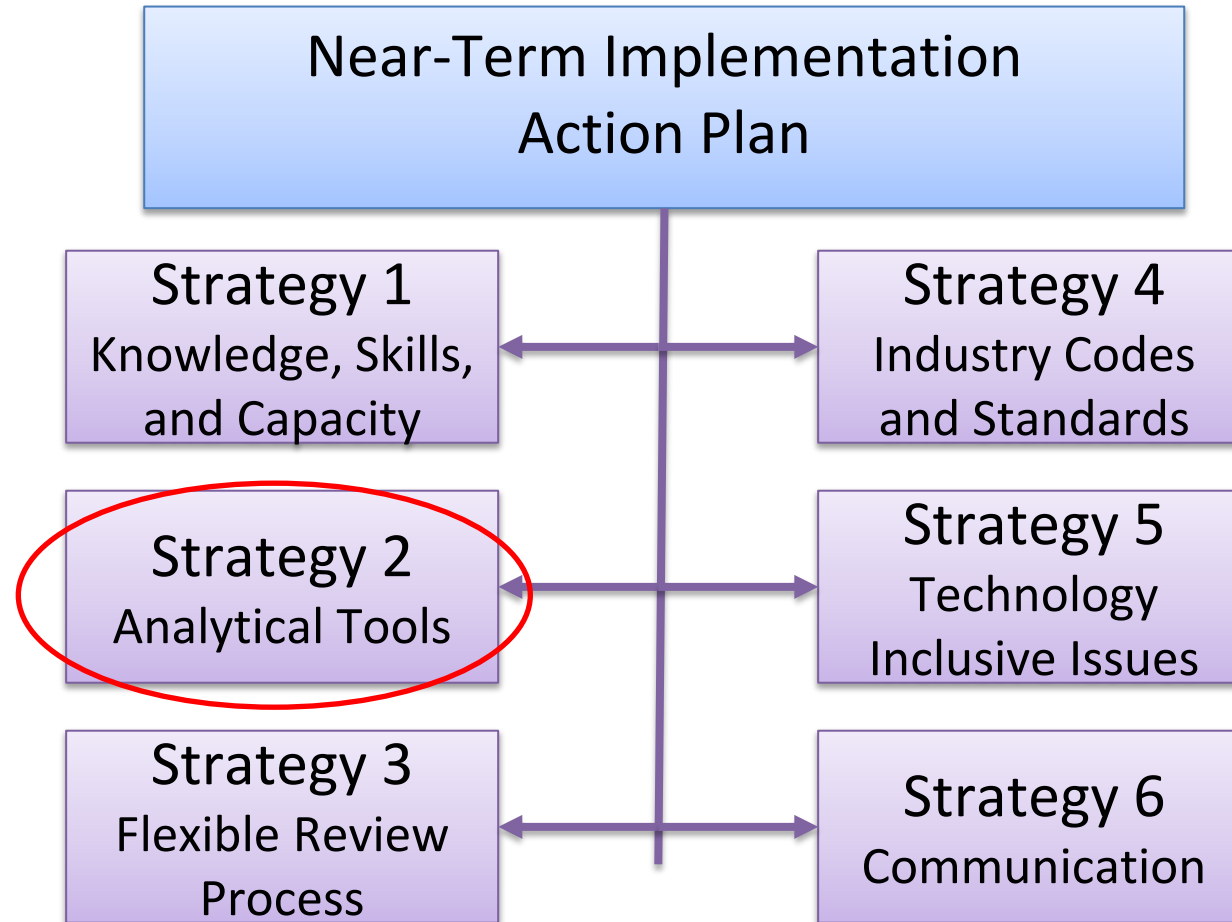

# IAP Strategy 2 Volumes

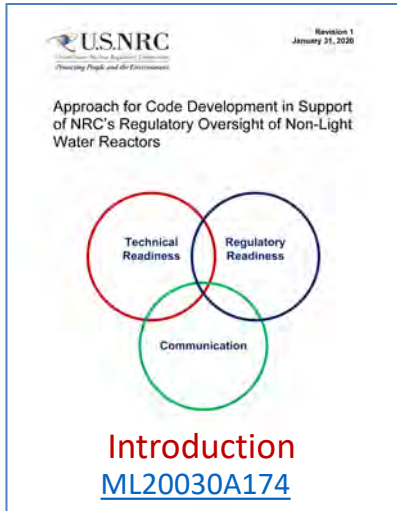

U.S. NRC  
Revision 1  
January 31, 2020

Approach for Code Development in Support of NRC's Regulatory Oversight of Non-Light Water Reactors

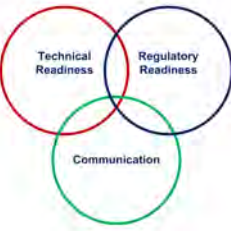

**Introduction**  
[ML20030A174](#)



U.S. NRC  
Revision 1  
January 31, 2020

NRC Non-Light Water Reactor (Non-LWR) Vision and Strategy, Volume 1 – *Computer Code Suite for Non-LWR Plant Systems Analysis*

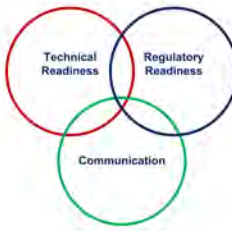

**Volume 1**  
[ML20030A176](#)



U.S. NRC  
Revision 1  
January 31, 2020

NRC Non-Light Water Reactor (Non-LWR) Vision and Strategy, Volume 2 – *Fuel Performance Analysis for Non-LWRs*



**Volume 2**  
[ML20030A177](#)



U.S. NRC  
Revision 1  
March 31, 2021

NRC Non-Light Water Reactor (Non-LWR) Vision and Strategy, Volume 4 – *Licensing and Siting Dose Assessment Codes*



**Volume 4**  
[ML21085A484](#)

These Volumes outline the specific analytical tools to enable independent analysis of non-LWRs, “gaps” in code capabilities and data, V&V needs and code development tasks.

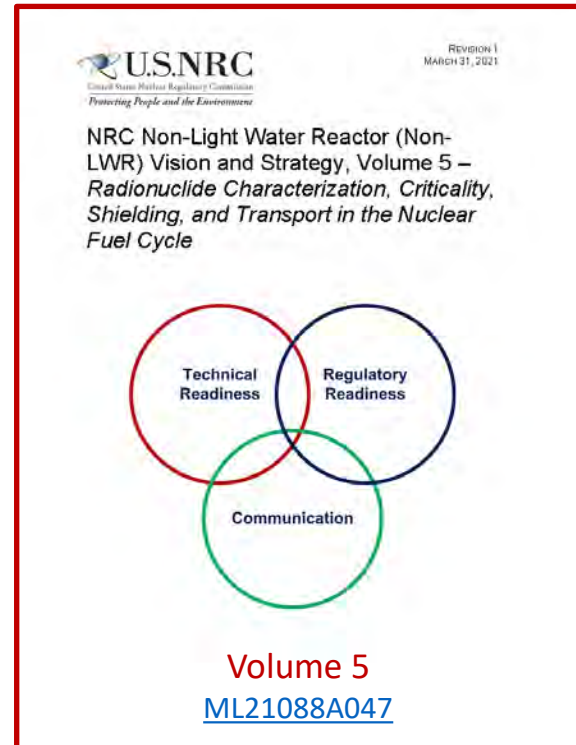

U.S. NRC  
Revision 1  
MARCH 31, 2021

NRC Non-Light Water Reactor (Non-LWR) Vision and Strategy, Volume 5 – *Radionuclide Characterization, Criticality, Shielding, and Transport in the Nuclear Fuel Cycle*

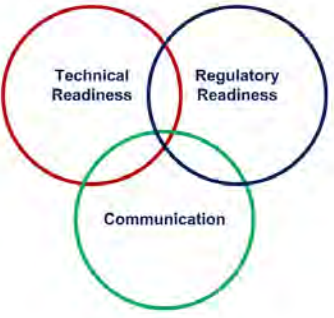

**Volume 5**  
[ML21088A047](#)

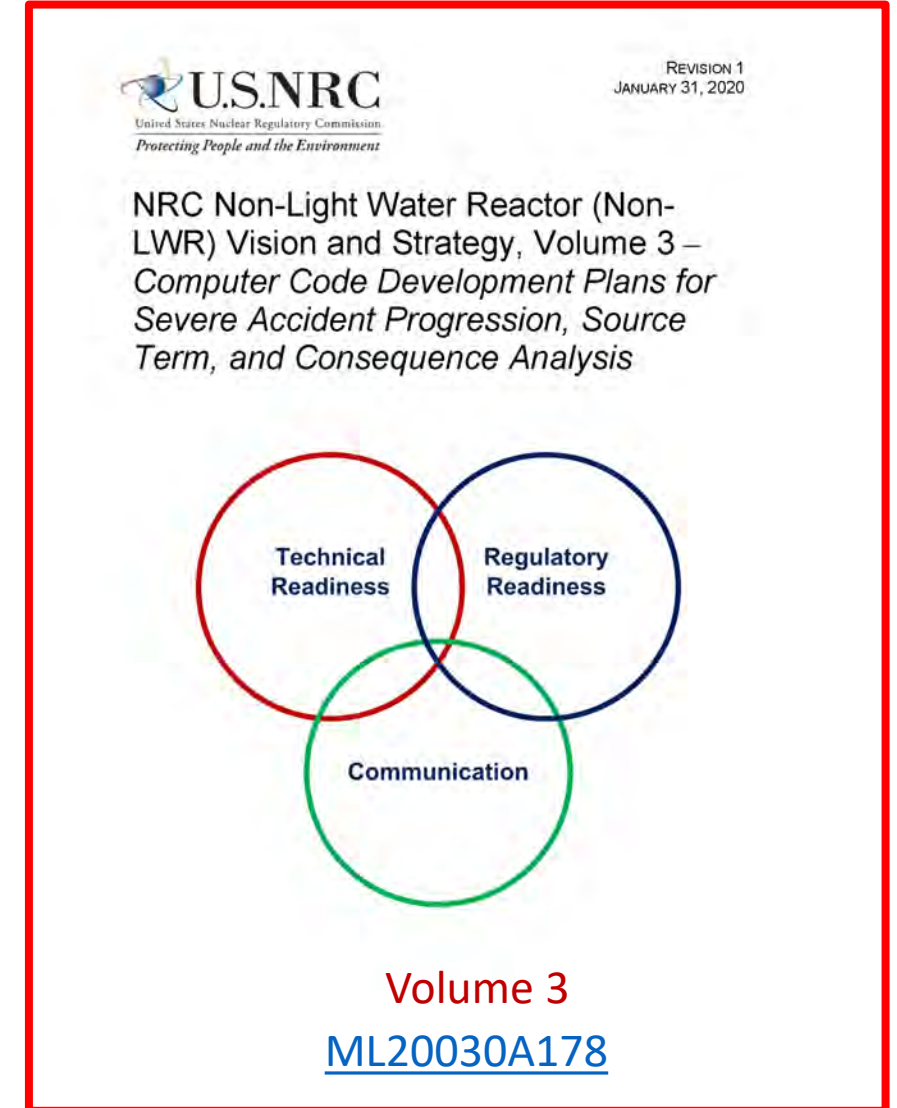

U.S. NRC  
United States Nuclear Regulatory Commission  
Protecting People and the Environment

REVISION 1  
JANUARY 31, 2020

NRC Non-Light Water Reactor (Non-LWR) Vision and Strategy, Volume 3 – *Computer Code Development Plans for Severe Accident Progression, Source Term, and Consequence Analysis*

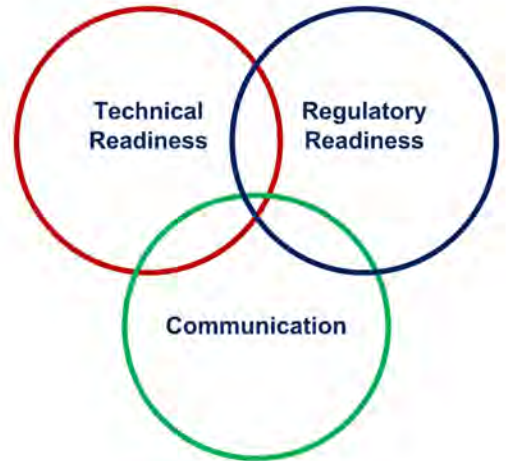

**Volume 3**  
[ML20030A178](#)

# NRC strategy for non-LWR analysis (Volume 3)

## Evaluation Model and Suite of Codes

Code strategy for source term  
 “NRC Non-Light Water Reactor Vision and Strategy, Volume 3 – Computer Code Development Plans for Severe Accident Progression, Source Term, and Consequence Analysis,” Revision 1, January 2020, ML20030A178

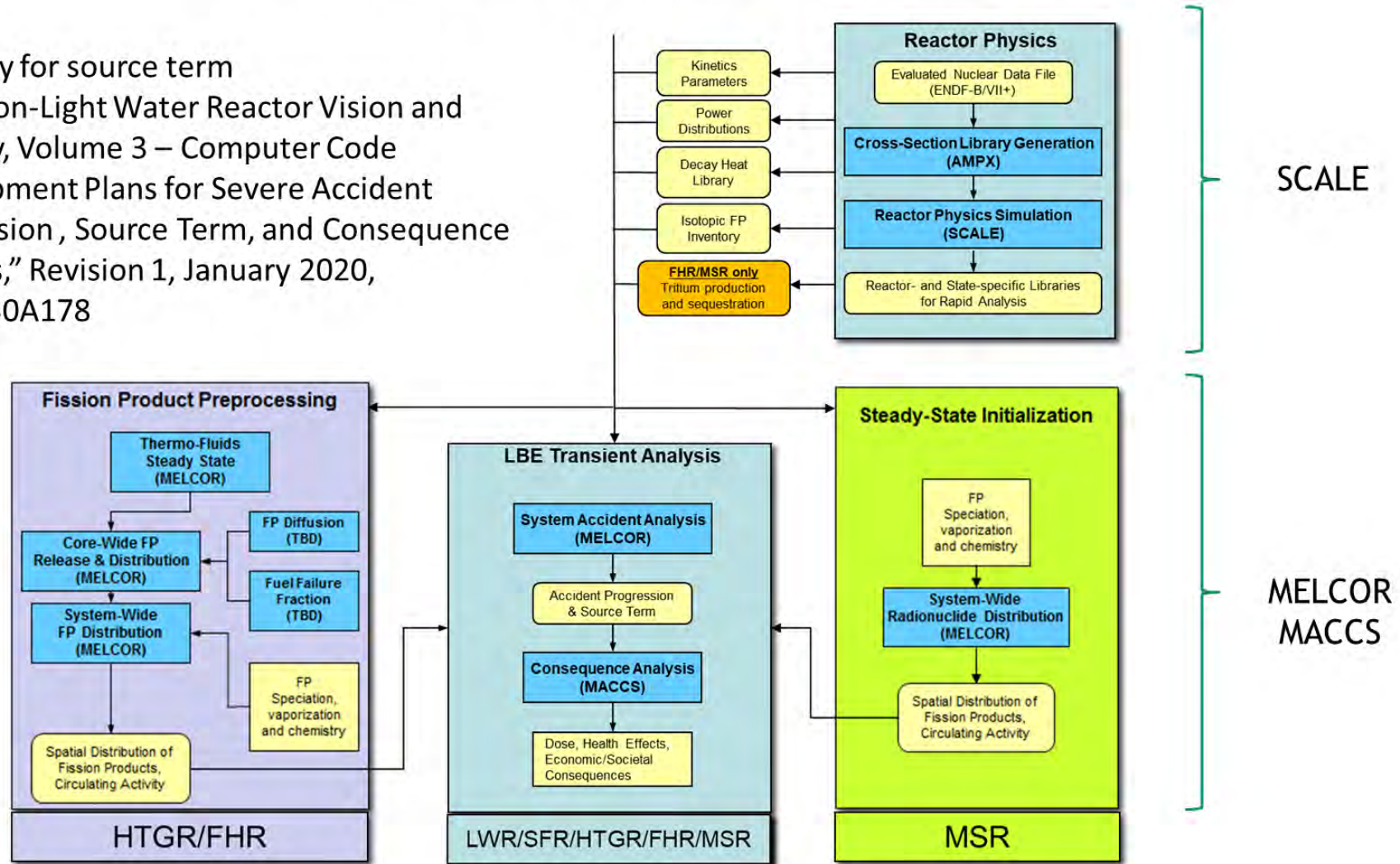

# Role of NRC severe accident codes

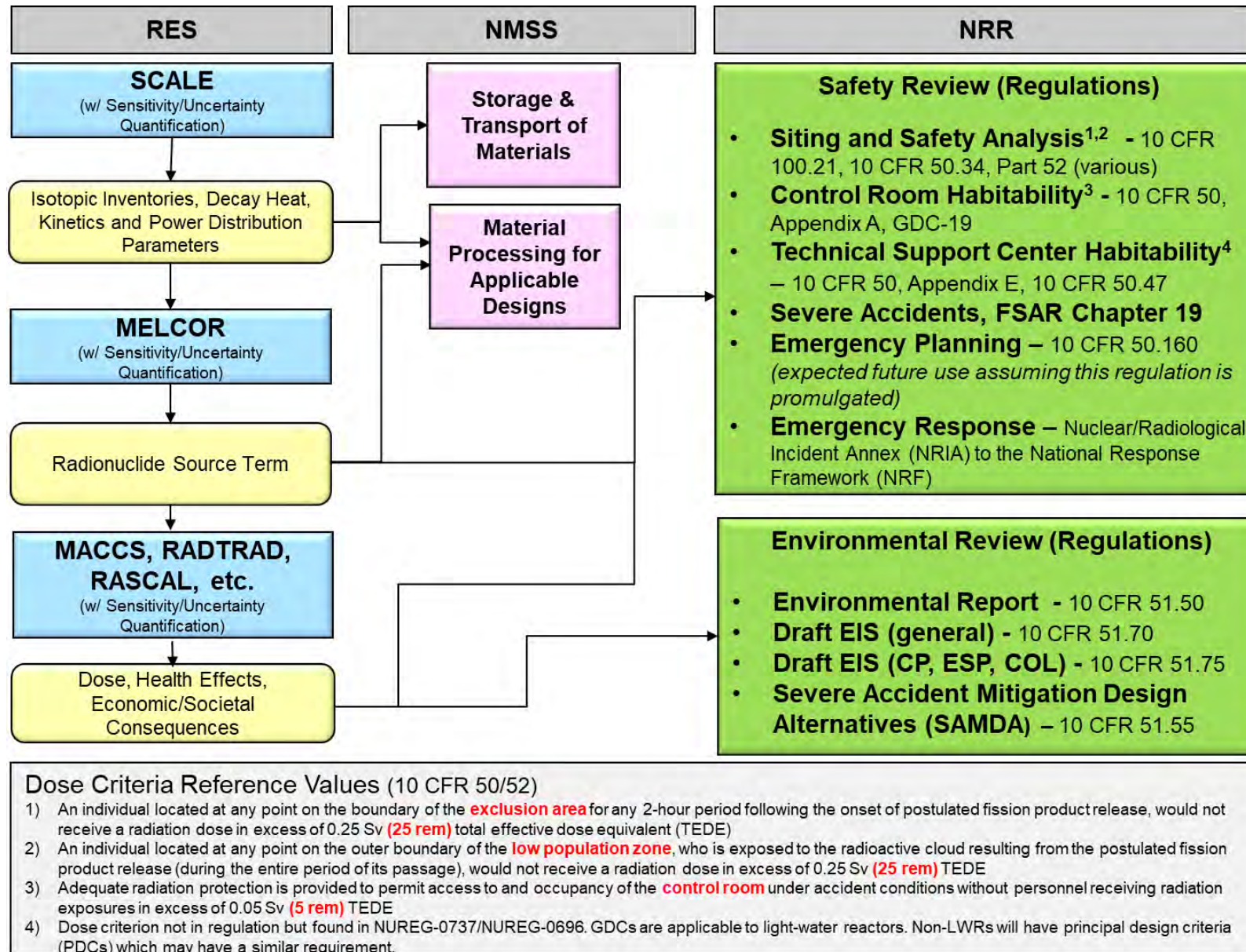

# Project Scope



**U.S. NRC**



# Project objectives

Understand severe accident behavior

- Provide insights for regulatory guidance

Facilitate dialogue on staff's approach for source term

Demonstrate use of SCALE and MELCOR

- Identify accident characteristics and uncertainties affecting source term
- Develop publicly available input models for representative designs



# Project scope

Full-plant models for three representative non-LWRs (FY21)

- Heat pipe reactor – INL Design A
- Pebble-bed gas-cooled reactor – PBMR-400
- Pebble-bed molten-salt-cooled – UC Berkeley Mark I

FY22

- Molten-salt-fueled reactor – MSRE
- Sodium-cooled fast reactor – To be determined

# Project approach

1. Build MELCOR full-plant input model
  - Use SCALE to provide decay heat and core radionuclide inventory
2. Scenario selection
3. Perform simulations for the selected scenario and debug
  - Base case
  - Sensitivity cases

# Advanced Reactor Designs

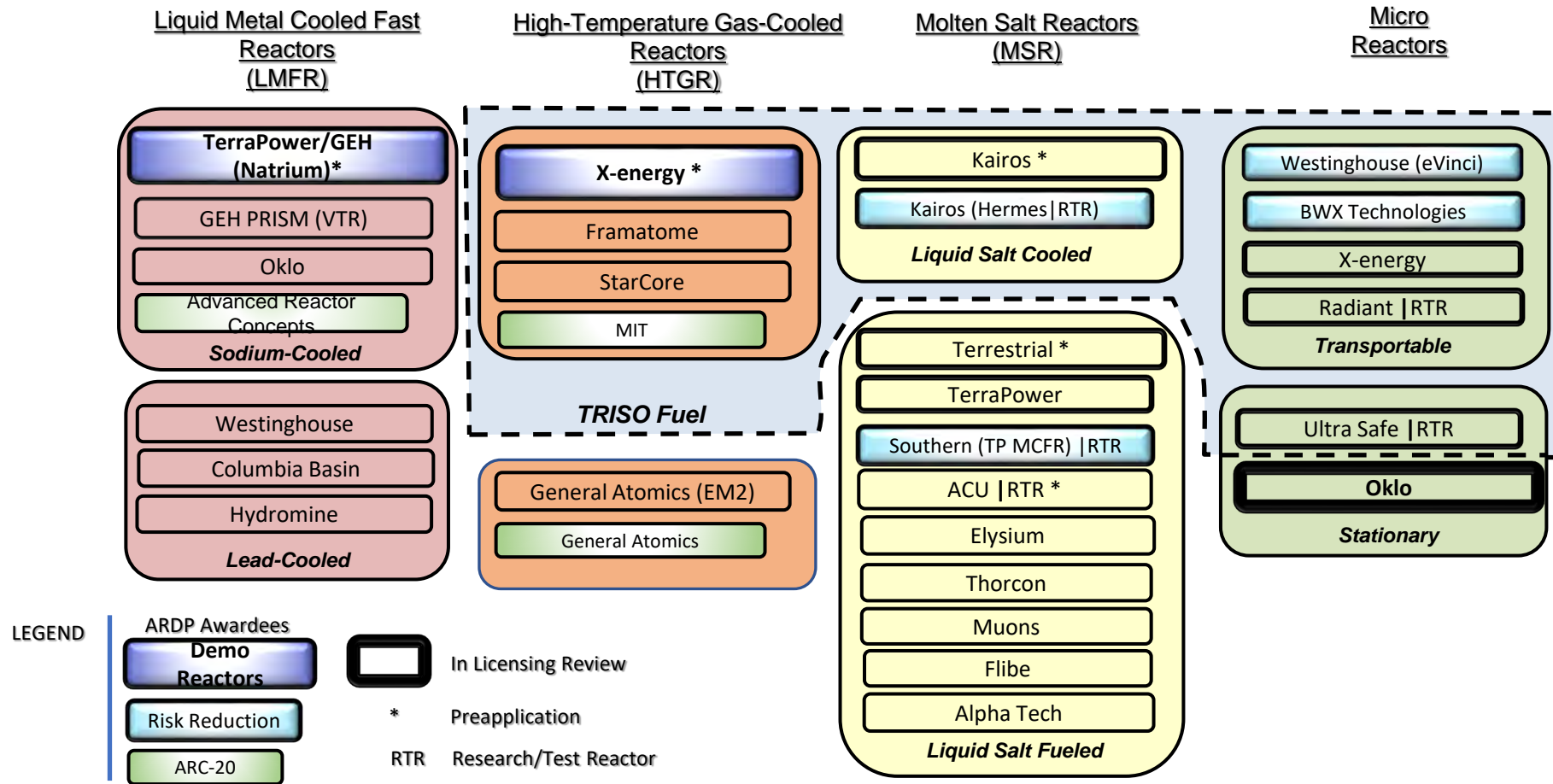

# High-Temperature Gas-Cooled Reactor



**U.S. NRC**



**Sandia  
National  
Laboratories**

# High-temperature gas-cooled reactor (1/2)

High-temperature high-pressure helium transfers heat from core to the secondary system

- Core outlet temperatures to 1000°C
- High temperature increases efficiency
- Fuel in a prismatic or a pebble bed core

## Peach Bottom Unit 1

- Operated 1966-1974
- 115 MW thermal power
- 37% efficiency, 88% availability

## Fort St. Vrain

- Operated 1979-1989
- 842 MW thermal power



**Peach Bottom Unit #1**

[[https://commons.wikimedia.org/wiki/File:Peach\\_Bottom\\_-\\_Aerial\\_View\\_1.jpg](https://commons.wikimedia.org/wiki/File:Peach_Bottom_-_Aerial_View_1.jpg)]

# High-temperature gas-cooled reactor (2/2)

## Department of Energy funded design of the Next Generation Nuclear Plant

- Project as established by Energy Policy Act of 2005
- Project started in 2007
- Initial focus on the PBMR-400 design
  - Pebble Bed Modular Reactor (Pty) Ltd
  - Focus of an Organization for Economic Cooperation and Development/Nuclear Energy Agency (OECD/NEA) neutronics benchmark study [NEA/NSC/DOC(2013)10]
- Areva SC-HTGR design was selected in 2012
- Department of Energy subsequently ended support

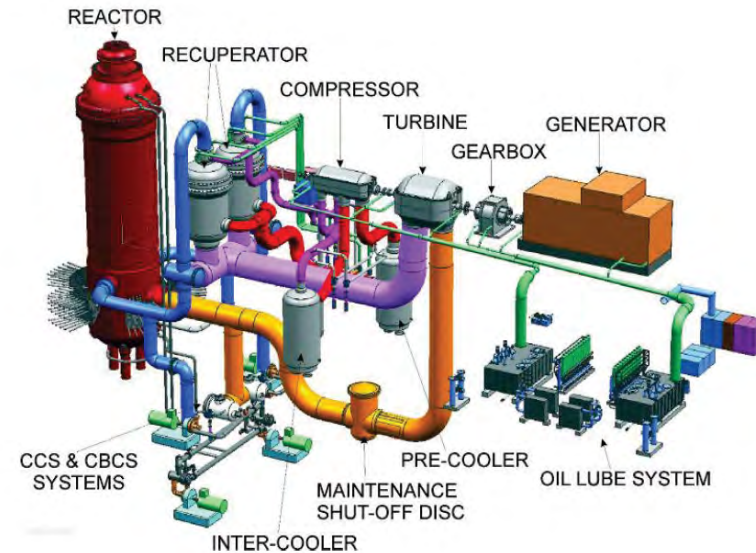

**PBMR-400**  
 [NEA/NSC/DOC(2013)10]

# Publicly available design

**PBMR-400** – Used for SCALE/MELCOR demonstration project

MELCOR model based on data from OECD/NEA neutronics benchmark project

- “Development of MELCOR Input Techniques for High Temperature Gas-cooled Reactor Analysis,” James Corson, Master’s thesis, Texas A&M University, 2010

No description of confinement or secondary system

- MELCOR confinement model based on NGNP schematics
- Simplified secondary system used to estimate steady-state conditions



# PBMR-400 (1/2)

400 MWt

Helium coolant

- Pressure – 9 MPa (1300 psi)
- Core inlet – 500°C
- Core outlet – 900°C
- Core flowrate (downward) – 192 kg/s

452,000 TRISO pebbles in an annular core

- Core inner diameter – 2.0 m
- Core outer diameter – 3.7 m
- Core height – 11 m

92 GWD/MTU target burn-up

Steel vessel with graphite reflectors

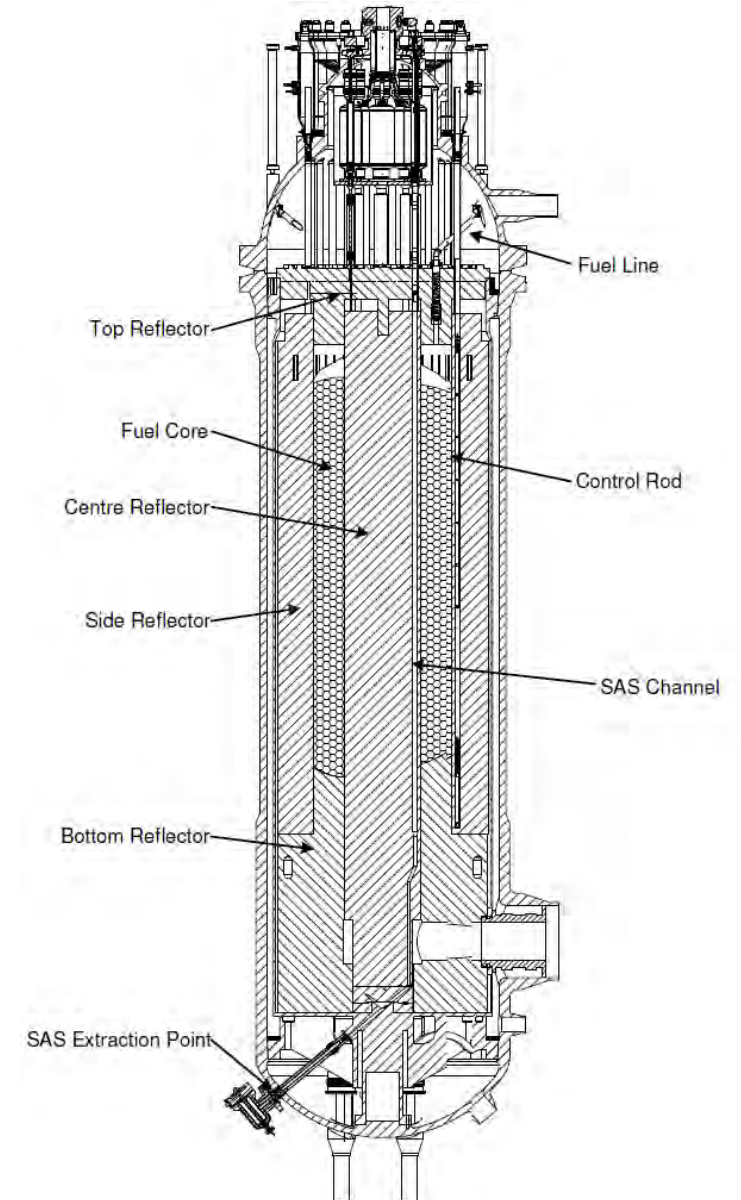



# PBMR-400 (2/2)

## TRISO particle

- TRISO is a portmanteau for **tr**istructural **i**sotropic
- Kernel – 1.5 g U; 250  $\mu\text{m}$  radius
- Porous carbon buffer layer
- 3 coatings to contain fission products

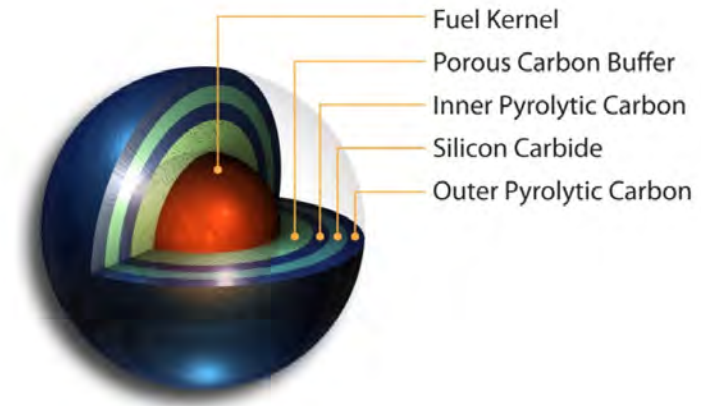

**TRISO particle**  
 [INL/EXT-08-14497]

## TRISO pebble

- Contains 14,500 TRISO particles
- 25 mm radius
- 5 mm graphite outer shell



**TRISO pebble**

[<https://www.energy.gov/ne/articles/x-energy-developing-pebble-bed-reactor-they-say-cant-melt-down>]

# HTGR Fission Product Inventory / Decay Heat Methods & Results



**U.S. NRC**



**Sandia  
National  
Laboratories**

# PBMR-400 benchmark used to represent PBR concepts

## Design features

- Fueled by graphite “pebbles” composed of  $\text{UO}_2$ -bearing TRISO fuel particles (5-10%  $^{235}\text{U}$ )
- Pebbles circulate multiple passes through the core to high discharge burnup ( $\sim 90$  GWd/MTIHM)

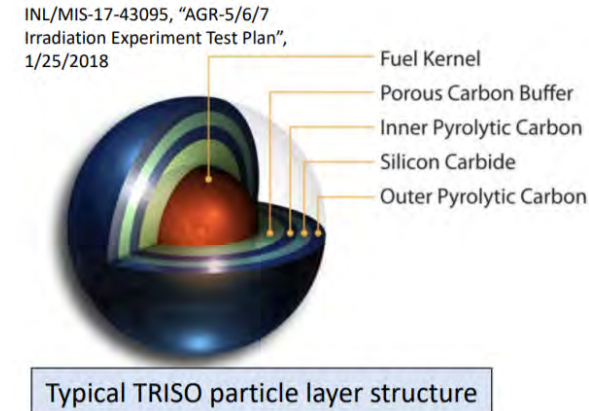

## Two cases evaluated

- **Startup core:** 1/3 fuel pebbles, 2/3 graphite “dummy” pebbles
- **Equilibrium core:** 110 material zones with pre-specified material compositions (100% fuel)

## References:

1. “Status and Prospects for Gas Cooled Reactor Fuels”, IAEA-TECDOC-CD-1614, April 2009
2. OECD/NEA, “PBMR Coupled Neutronics / Thermal-hydraulics Transient Benchmark I: The PBMR-400 Core Design,” NEA/NSC/DOC(2013)10, July 2010

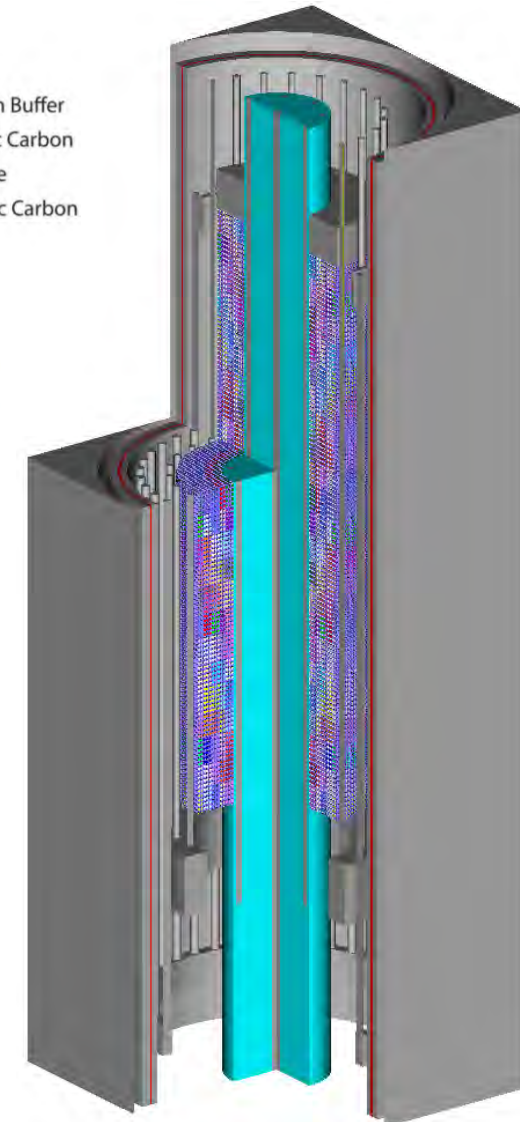

PBMR-400 SCALE geometry  
(S. Skutnik, ORNL)

# Prior SCALE validation for HTGR systems (1/2)

- **HTR-10 initial core critical benchmark**
  - Based on International Handbook of Evaluated Reactor Physics Benchmark Experiments (IRPhE) benchmark for HTR-10 initial core
  - Graphite-coated, spherical fuel elements with TRISO fuel particles
    - 3 cm fuel spheres at 17%  $^{235}\text{U}$  enrichment
  - SCALE 6.0 with ENDF/B-VIII.0 nuclear data
  - **Figure of merit:** System k-eigenvalue ( $k_{\text{eff}}$ )
    - SCALE consistent with MCNP to within  $-73 \pm 34$  pcm
    - MCNP and SCALE calculations both showed a moderate positive reactivity bias ( $1.4 \pm 0.4$ )%

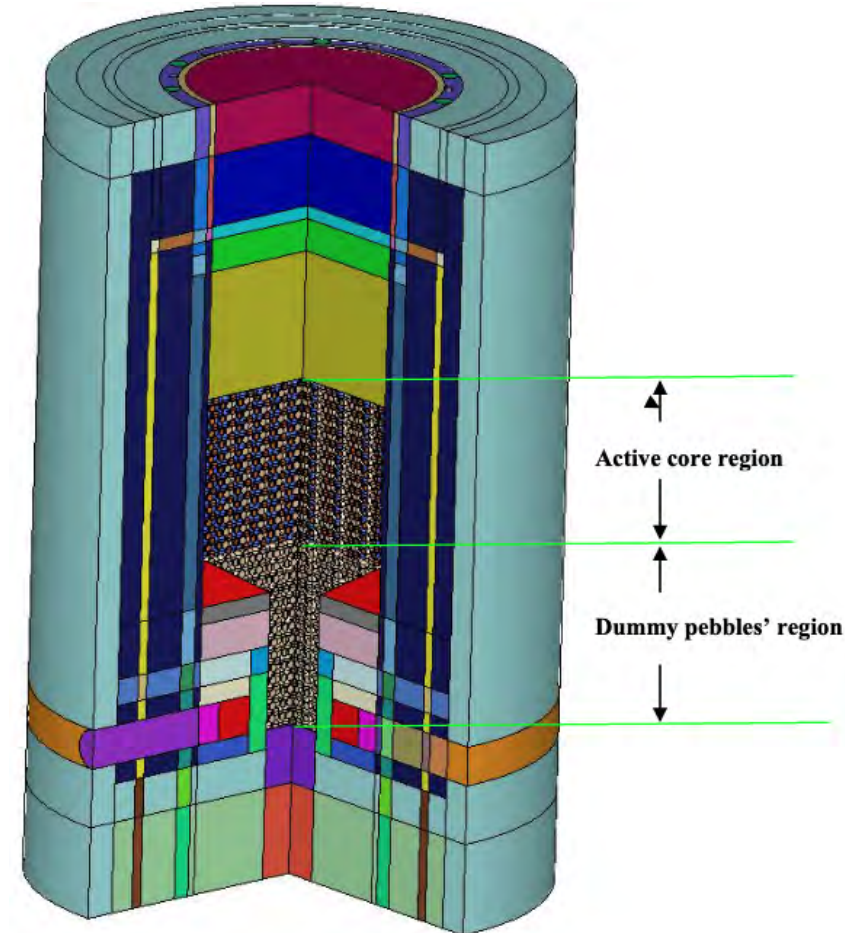

Image: NUREG/CR-7107

G. Ilas, D. Ilas, R. P. Kelly, and E. E. Sunny, "Validation of SCALE for High Temperature Gas-Cooled Reactor Analysis," NUREG/CR-7107(ORNL/TM-2011/161), Jul. 2012

# Prior SCALE validation for HTGR systems (2/2)

- **HTR-PROTEUS critical benchmark**

- IRPhE benchmark based upon critical experiments performed at PROTEUS facility (Paul Scherrer Institut, Switzerland)
  - 10 deterministic pebble packing arrangements with 3 random close-packed arrangements
  - Graphite-coated spherical fuel elements with TRISO fuel particles
  - 3 cm radius graphite spheres (2.35 cm fuel region radius), 16.7% <sup>235</sup>U enrichment
- **Figure of merit:** System k-eigenvalue ( $k_{\text{eff}}$ )

	<b>Difference with MCNP5 (pcm)</b>			
	ENDF/B-VI		ENDF/B-VII.0	
	<b>Average</b>	<b>Maximum</b>	<b>Average</b>	<b>Maximum</b>
Columnar hexagonal point-on-point (CHPOP)	422 ± 93	667 ± 82	804 ± 87	1302 ± 811
Hexagonal close-packed (HCP)	252 ± 93	353 ± 84	782 ± 95	801 ± 85

G. Ilas, D. Ilas, R. P. Kelly, and E. E. Sunny, "Validation of SCALE for High Temperature Gas-Cooled Reactor Analysis," NUREG/CR-7107(ORNL/TM-2011/161), Jul. 2012

# Workflow

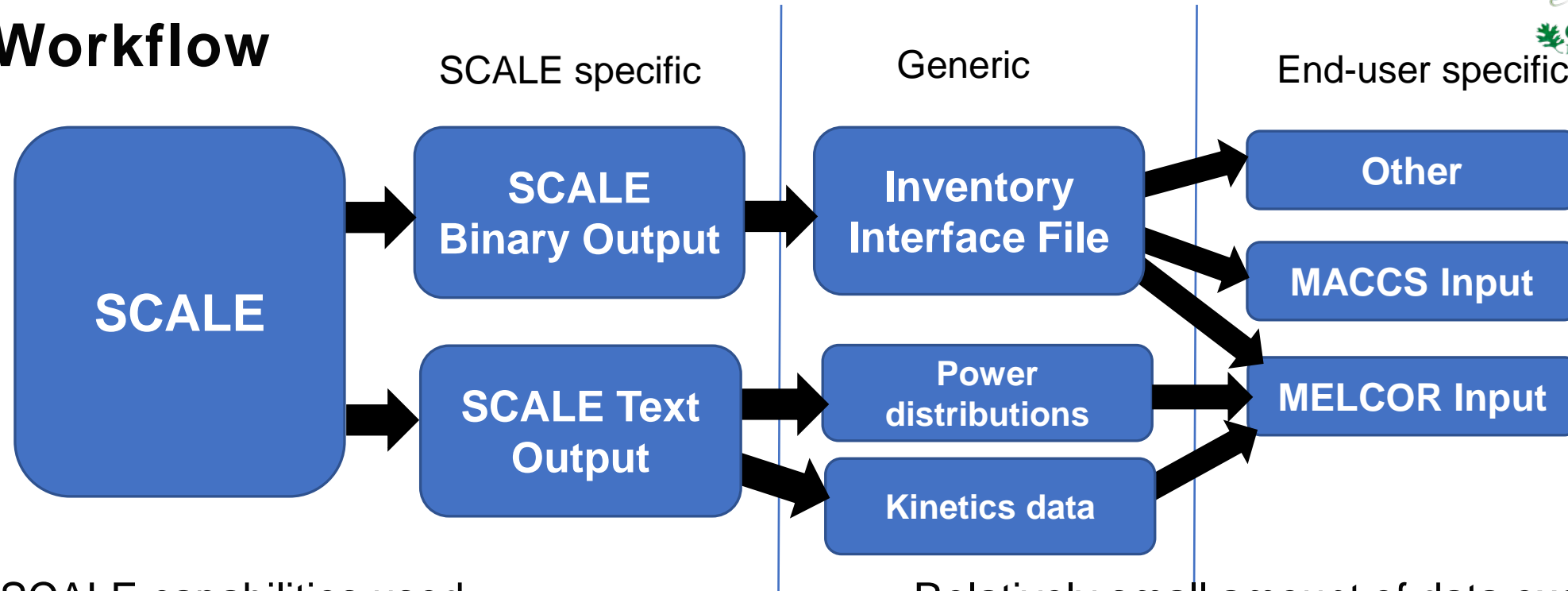

- SCALE capabilities used
  - KENO or Shift\* 3D Monte Carlo transport
  - ENDF/B-VII.1 continuous energy physics
  - ORIGEN for depletion
  - Sequences
    - CSAS for reactivity (e.g. rod worth)
    - TRITON for reactor physics & depletion

- Relatively small amount of data except for nuclide inventory
  - new interface file developed for inventory using standard JSON format
  - easily read in python and post-processed into MELCOR or MACCS input
  - contains nuclear data such as decay Q-value for traceability when performing UQ studies

\*To be released with SCALE 6.3

# General ORNL Methodology for Fuel Inventory

- ORNL has used a methodology with the Oak Ridge Isotope GENERation (ORIGEN) code to rapidly generate inventories using **ORIGEN reactor libraries**
- SCALE/ORIGEN use of fundamental nuclear data allows the following to be calculated from nuclide inventory (moles of each nuclide in a system)
  - mass
  - decay heat
  - activity
  - gamma emission
  - neutron emissions
- With SCALE 6.2 (2016), the sequence ORIGAMI was released which is the modern approach of using ORIGEN reactor libraries

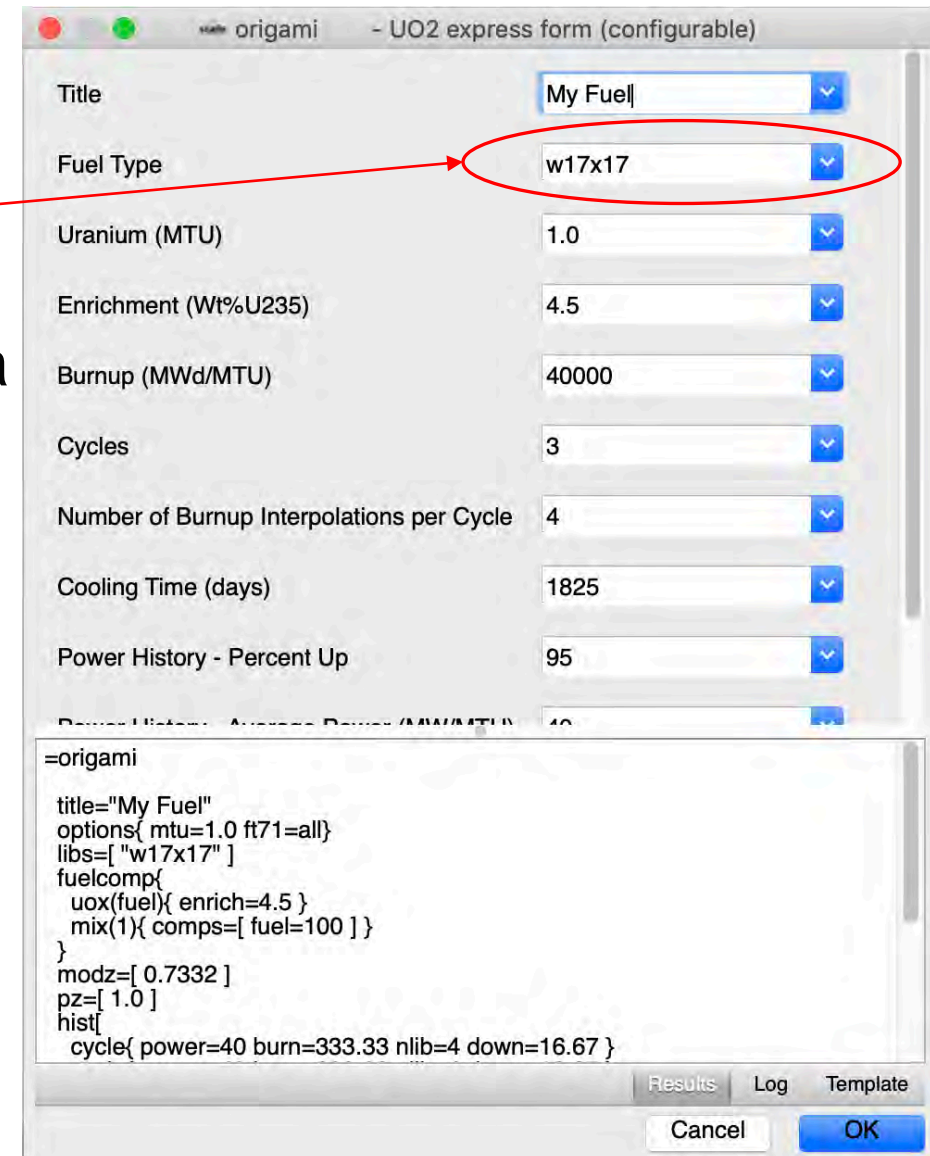

origami - UO2 express form (configurable)

Title	My Fuel
Fuel Type	w17x17
Uranium (MTU)	1.0
Enrichment (Wt%U235)	4.5
Burnup (MWd/MTU)	40000
Cycles	3
Number of Burnup Interpolations per Cycle	4
Cooling Time (days)	1825
Power History - Percent Up	95
Power History - Average Power (MW/MTU)	40

```

=origami
title="My Fuel"
options{ mtu=1.0 ft71=all}
libs=[ "w17x17" ]
fuelcomp{
  uox(fuel){ enrich=4.5 }
  mix(1){ comps=[ fuel=100 ] }
}
modz=[ 0.7332 ]
pz=[ 1.0 ]
hist[
  cycle{ power=40 burn=333.33 nlib=4 down=16.67 }

```

Results Log Template

Cancel OK

# Plans for SCALE/ORIGAMI and HTGR

- Soon ORIGAMI will have a new **PBMR-400 fuel type** and the ability to generate (in seconds)
  - fuel inventory for a PBMR-400 pebble
  - initial enrichment
  - specific power history
  - cooling time
- Generalizing what we learn for the PBMR-400 will enable future **HTGR fuel types**

Current Fuel Types

The screenshot shows the ORIGAMI software interface. The 'Fuel Type' dropdown menu is open, displaying a list of fuel types. The 'w17x17' option is circled in red. A red arrow points from the text 'Current Fuel Types' to this list. Below the form, a text area shows the generated XML configuration for the selected fuel type.

```

=origami
title="My Fuel"
options{ mtu=1.0 ft71=all}
libs=[ "w17x17" ]
fuelcomp{
  uox(fuel){ enrich=4.5 }
  mix(1){ comps=[ fuel=100 ] }
}
modz=[ 0.7332 ]
pz=[ 1.0 ]
hist{
  cycle{ power=40 burn=333.33 nlib=4 down=16.67 }
}
  
```

Results Log Template

Cancel OK

>50 different fuel types supported!



# HTGR analysis with SCALE: Overview

- **Key assumptions**

- License applications will specify pebble circulation strategy and equilibrium core
- Analyzing the equilibrium core is the limiting case from an inventory/decay heat standpoint

- **Main goals**

- Evaluate neutronic characteristics
- Generate inventory and decay heat for the MELCOR nodalization **which may differ** from how the application specifies their equilibrium core isotopics
- Generate individual pebble inventory within a core zone/batch (e.g., difference between fresh vs. once-through pebble in a single core zone)
- Generate discharge pebble inventory/decay heat with sensitivity/uncertainty analysis

**PBMR-400  
equilibrium core**

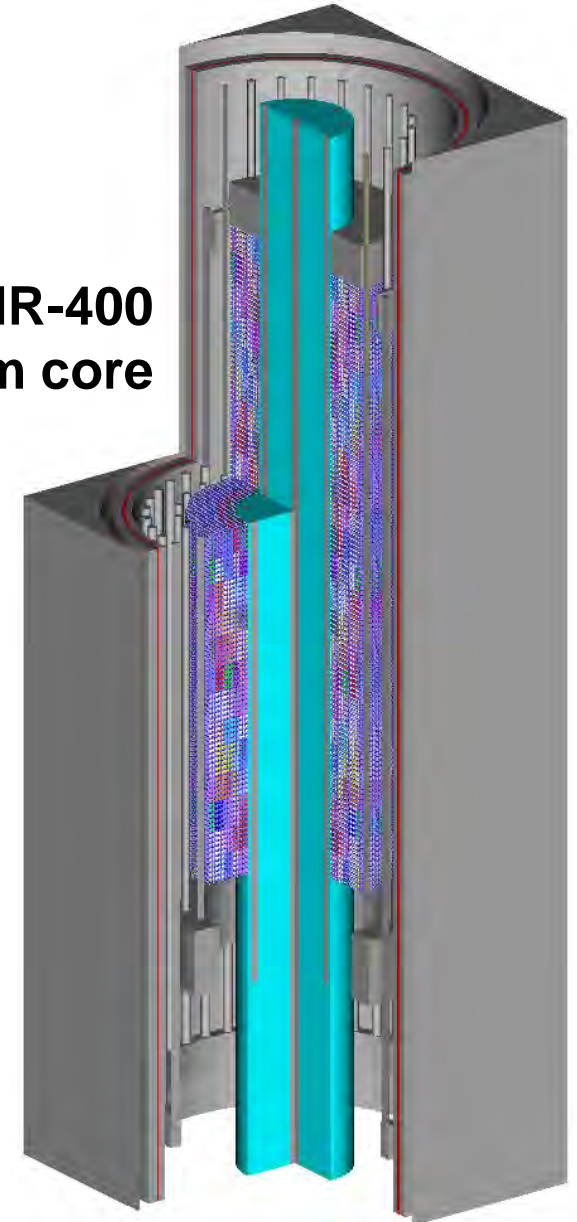

# Analysis areas

1. Pebble packing
2. Temperature feedback
3. Radial/axial spectral variation
4. Pebble flow
5. TRITON model scope for ORIGEN library generation
  - (i.e. what matters for producing one-group sections)

**PBMR-400  
equilibrium core**

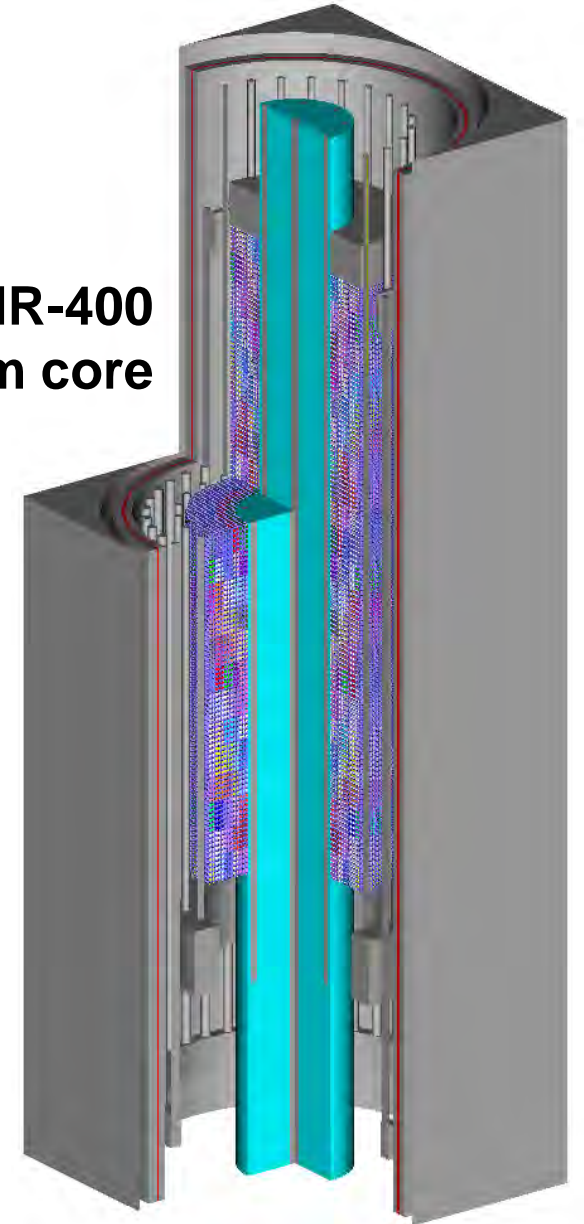

# 1. Pebble packing

PBMR-400 benchmark specifies ~452,000 fuel pebbles with a packing fraction of 61%

Can be achieved using a BCC lattice (dodecahedral) of unbroken spheres, however substantial negative bias in  $k_{\text{eff}}$  observed due to local voids near reflector regions

Present best estimate models use “clipped pebbles” at boundary to maintain uniform local packing fraction

- Similar to modeling approaches used for HTR-10<sup>†</sup>

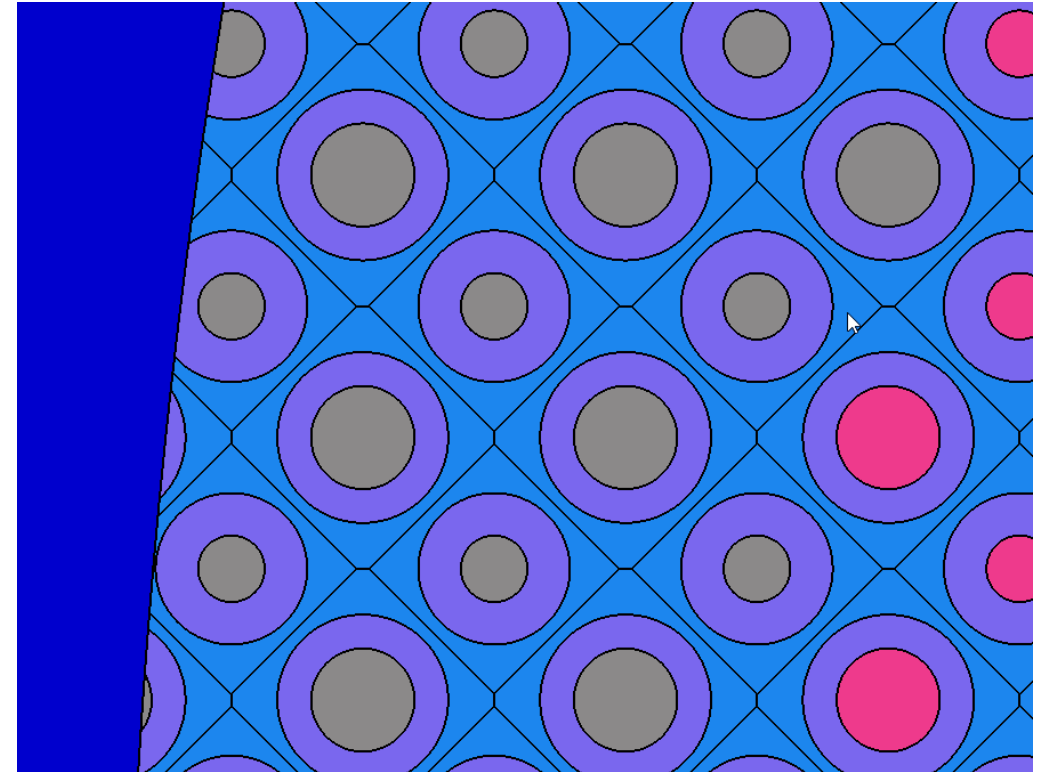

Image: S. Skutnik, ORNL

<sup>†</sup> J.-Y. Hong, S.-R. Wu, S.-C. Wu, D.-S. Chao, J.-H. Liang, “Burnup computations of multi-pass fuel loading scenarios in HTR-10 using a pre generated fuel composition library,” *Nuclear Engineering and Design*, 374 (2021)

## 2. Temperature feedback (1/2)

Estimation of specific reactivity feedback components (e.g., temperature reactivity coefficients of fuel, moderator) requires detailed thermal hydraulic analysis of core

**Strong coupling** between neutronics & thermal hydraulics

### Approach: Using system isotherms

- All system materials adjusted to a fixed temperature
  - e.g., 300, 600, 900, 1200 K
- Does not afford specific isolation of moderator / fuel temperature coefficients

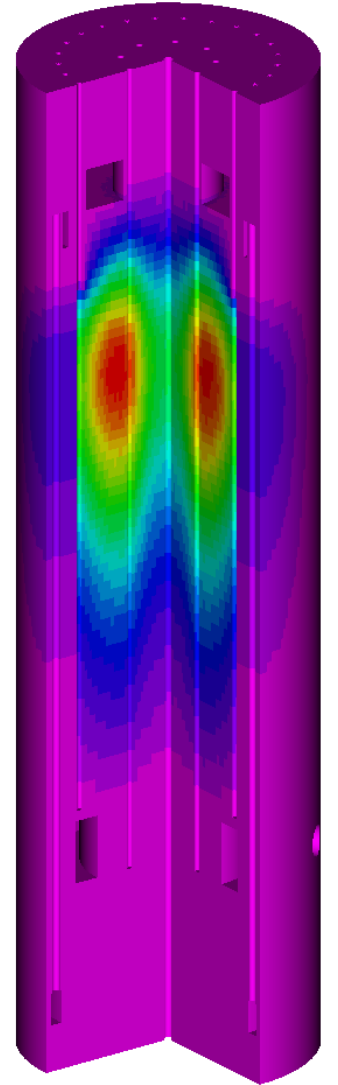

PBMR-400 total neutron flux, from SCALE/Shift 3D Monte Carlo Calculation (S. Skutnik, ORNL)

## 2. Temperature feedback (2/2)

Strong temperature-driven spectral shifts, especially toward  $^{239}\text{Pu}$  low-lying resonance

Fresh core

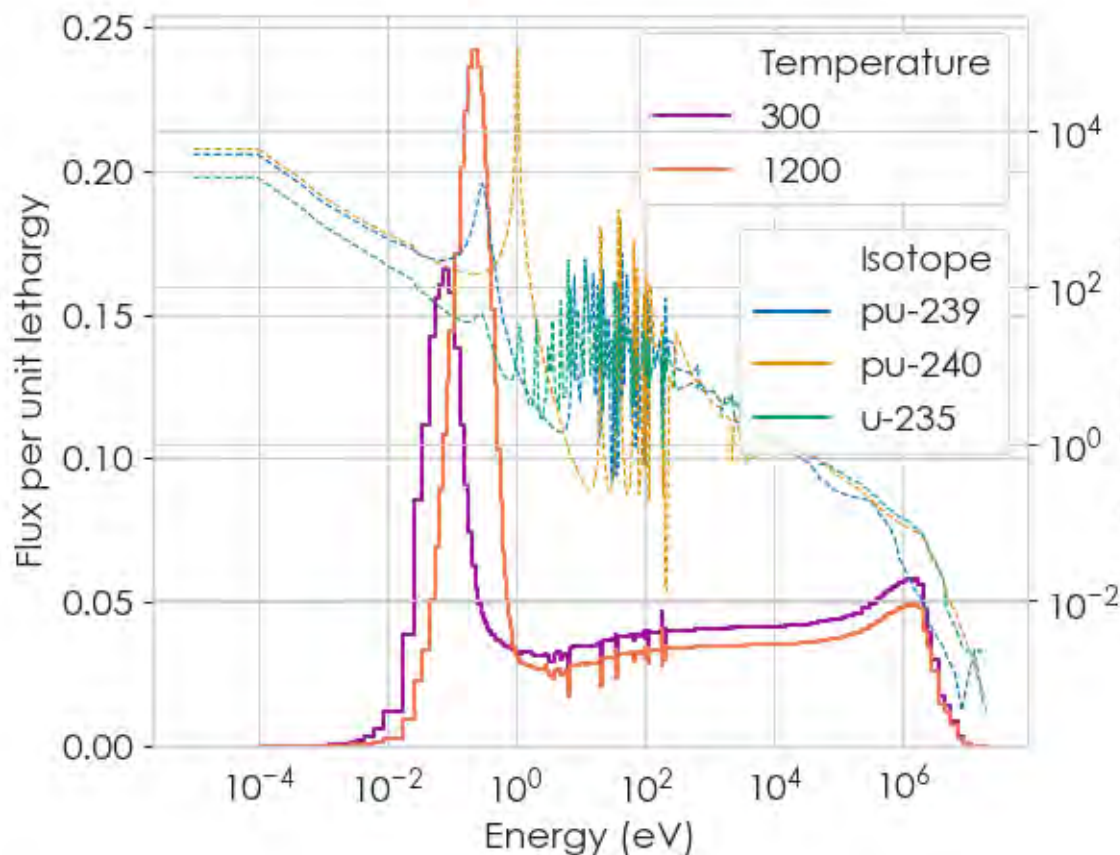

Equilibrium core

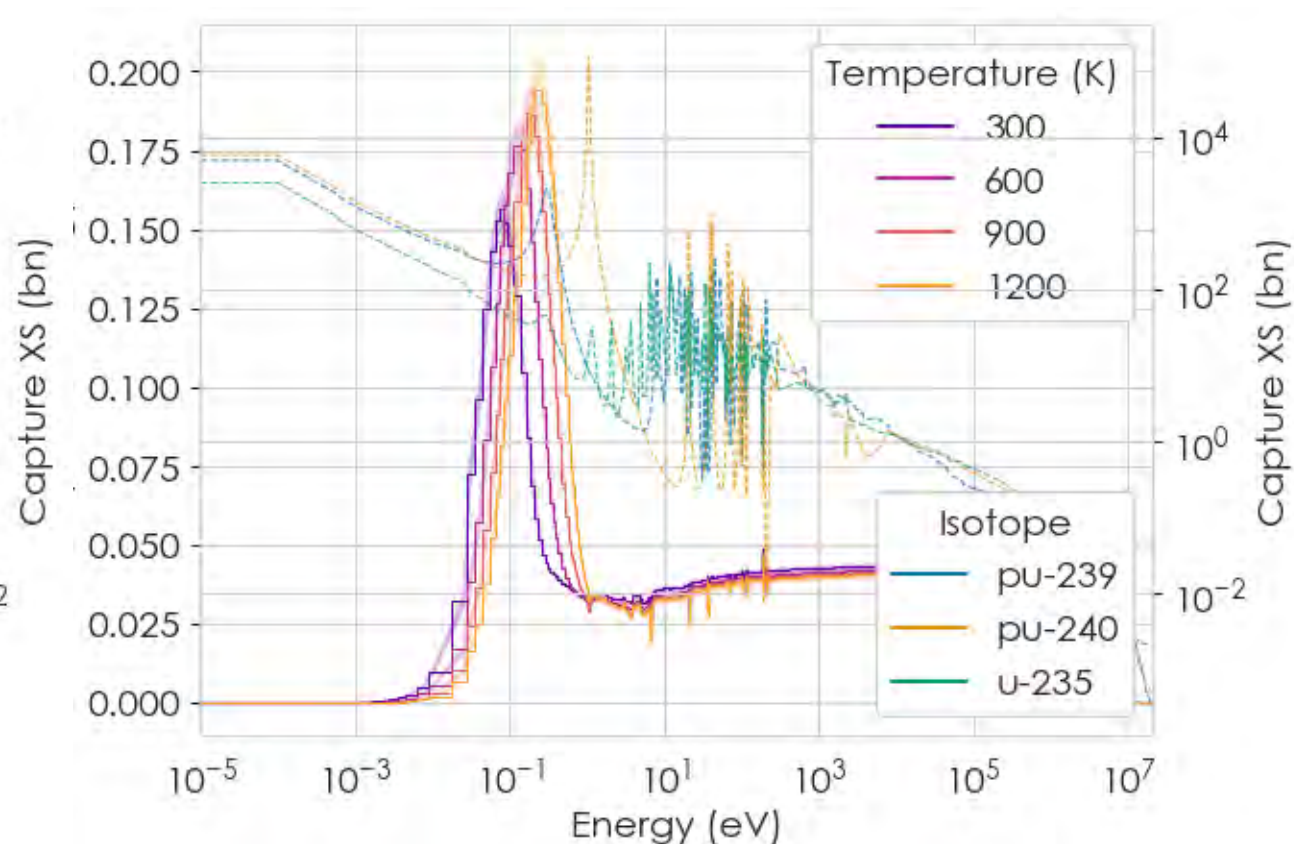

### 3. Flux shape shows a top-weighted distribution due to pebble loading & depletion

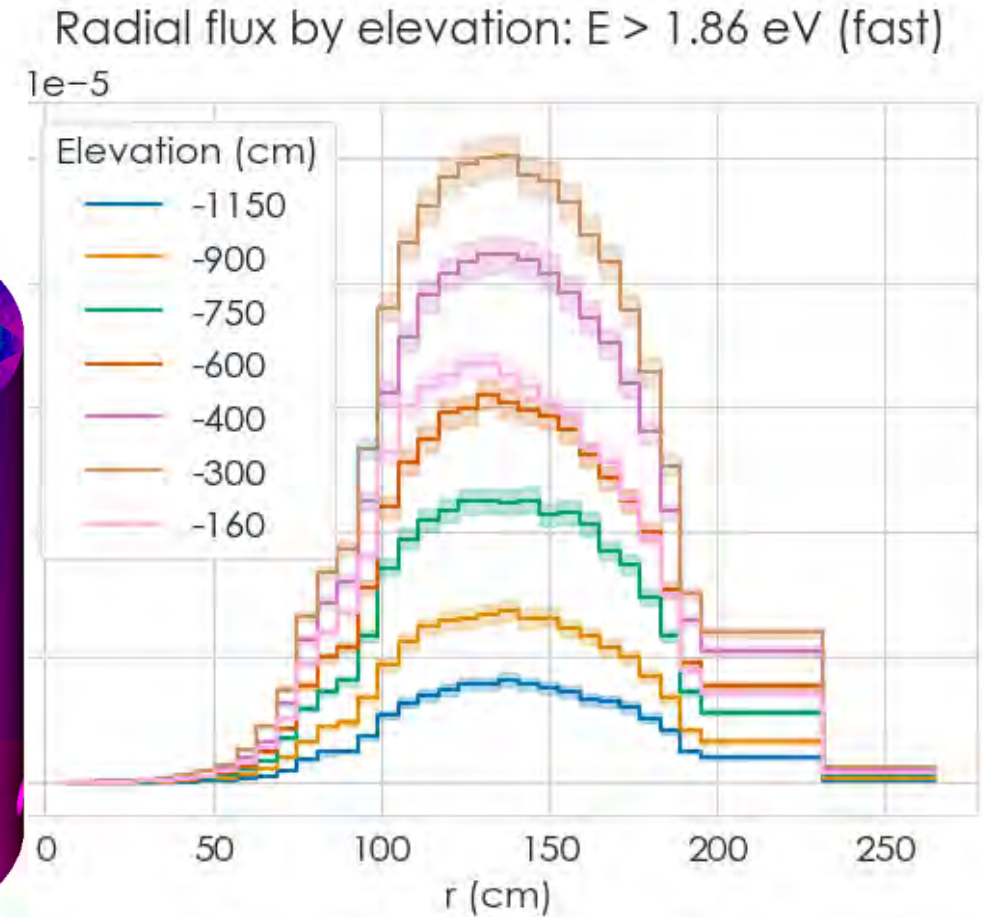
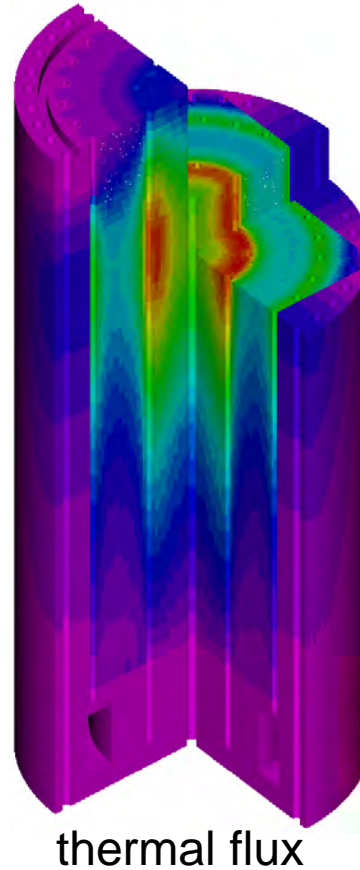
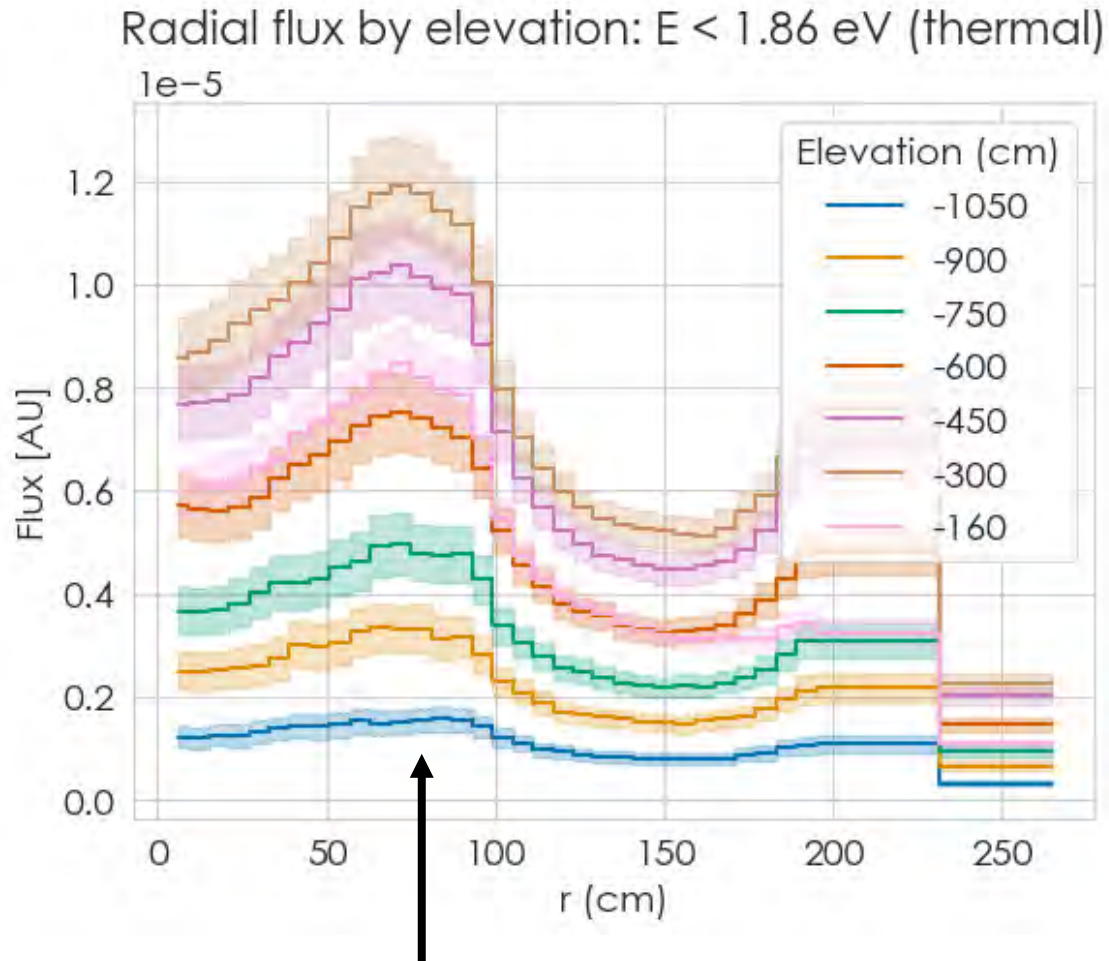

Strong power peaking effects observed near graphite reflector regions (esp. interior)

### 3. Fast : thermal flux ratio (spectral index) sensitive to radial zone; relatively invariant axially

#### Axial

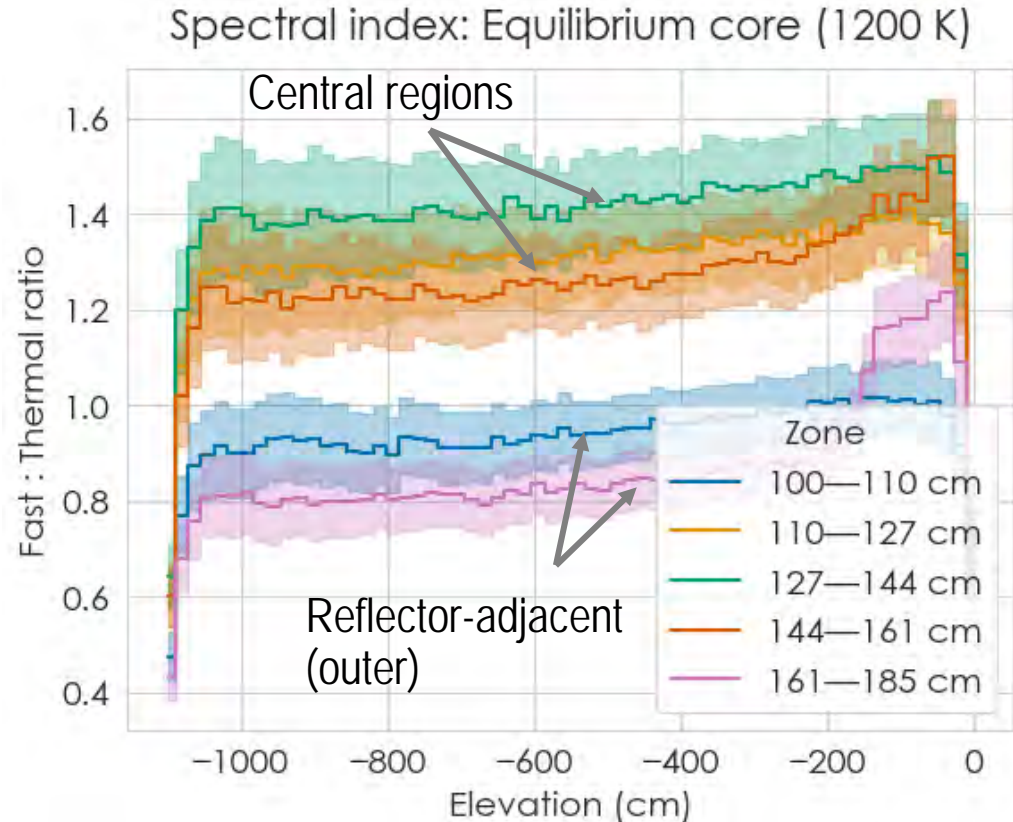

#### Radial

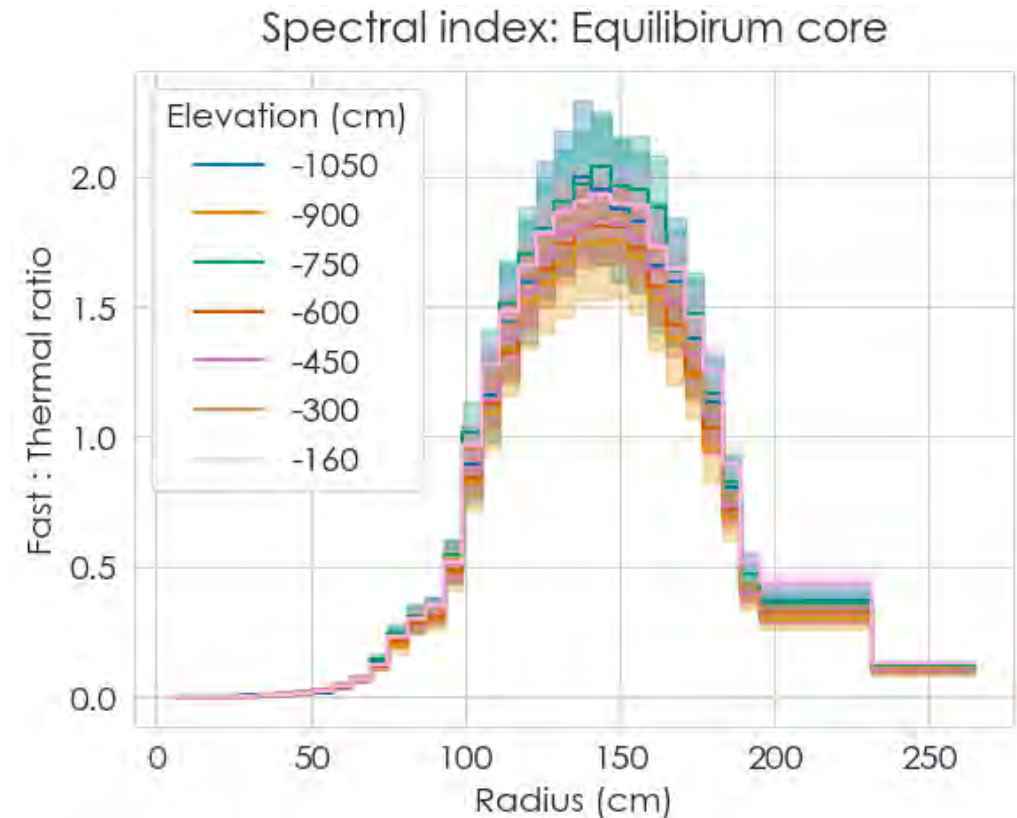

Major spectral shifts primarily occur across **radial** zones; i.e., primarily need **radial** zone Origen libraries

## 4. Continuous circulation of pebbles in the core

**Approach:** “Equilibrium” compositions derived from previous equilibrium core calculation with flowing pebbles (VSOP)

- Pebble locations currently treated as “static” in a full-core, 3-D Monte Carlo neutron transport calculation
- Discrete axial and radial material zones, representing spatially-dependent “average” at equilibrium after several months of operation

### Similarity to prior approaches:

- VSOP:<sup>1</sup> Depletion of fixed core compositions to a pre-defined  $k_{\text{eff}}$ , then shuffle zones downward, reload pebbles at top of core and repeat. Depletion assumes admixture of fresh & burned pebbles exposed to same depleting flux
- HTR-10 multi-pass pebble burnup analysis<sup>2</sup> follows similar procedure to VSOP

#### References:

1. HJ. Rütten, K.A. Haas, H. Brockmann, W. Scherer, “V.S.O.P. (99/05) Computer Code System” (2005)
2. J.-Y. Hong, S.-R. Wu, S.-C. Wu, D.-S. Chao, J.-H. Liang, “Burnup computations of multi-pass fuel loading scenarios in HTR-10 using a pre generated fuel composition library,” *Nuclear Engineering and Design*, 374 (2021)

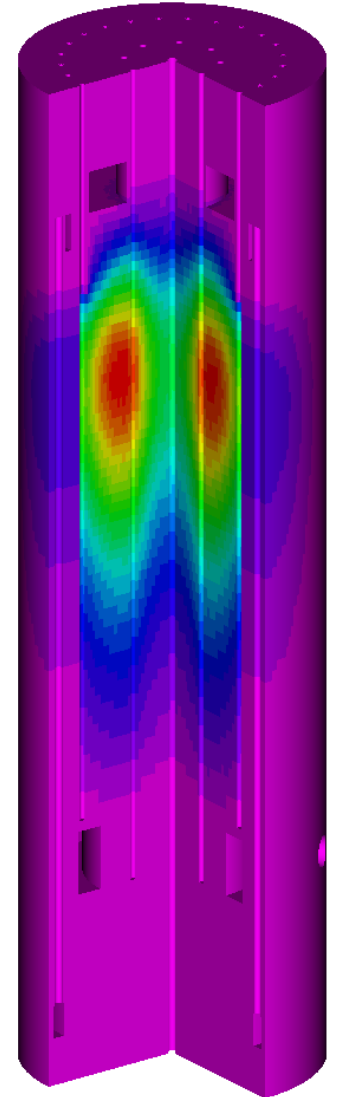

PBMR-400 total neutron flux from SCALE/Shift 3D Monte Carlo calculation (S. Skutnik, ORNL)



## 4. Capturing possible pebble transit paths through the core (velocity differentials & cross-flow)

### Current assumptions:

- Pebble transit dominated by vertical motion; can capture differential velocity across radial regions
- Active core modeled as a right-cylindrical annulus (cylindrical shell)

### Similarity to prior approaches:

- VSOP: Pebble transit assumed to be in parallel vertical dimensions unless user specifies otherwise
- HTR-10 burnup analysis normalizes pebble residence time based on assumed transit path (conical funneling)<sup>†</sup>; recycled pebbles uniformly redistributed across top of core

<sup>†</sup>J.-Y. Hong, S.-R. Wu, S.-C. Wu, D.-S. Chao, J.-H. Liang, "Burnup computations of multi-pass fuel loading scenarios in HTR-10 using a pre generated fuel composition library," *Nuclear Engineering and Design*, 374 (2021)

# 5. ORIGEN library analysis strategy

Evaluate PBMR-400 cross-sections & isotopic responses at different levels of model fidelity

Lower fidelity  
Lower computational cost

High fidelity  
High computational cost

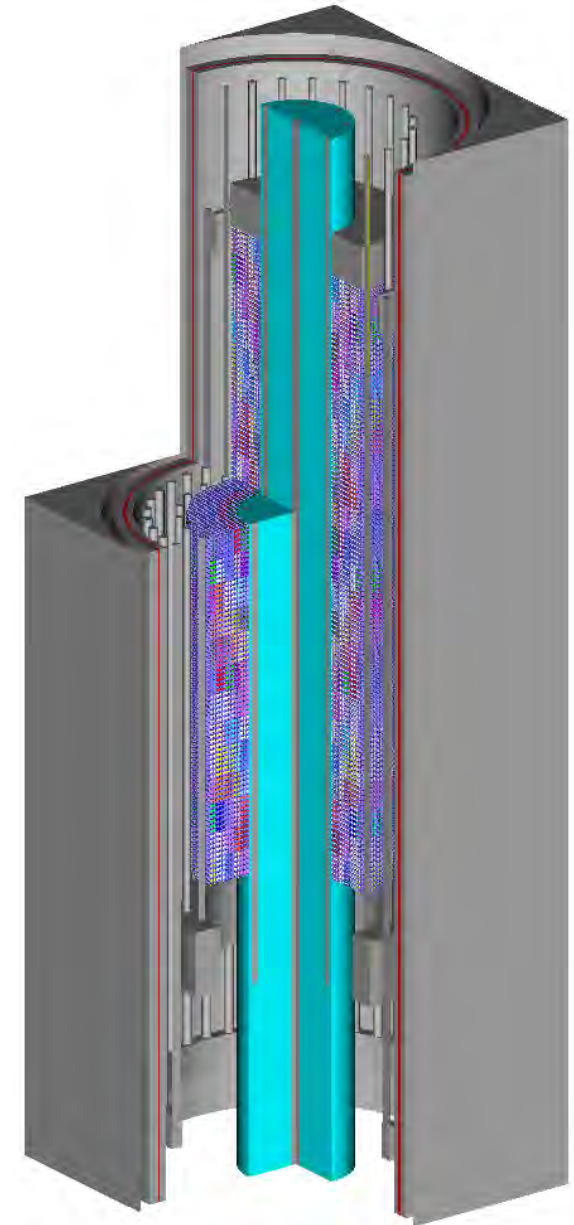
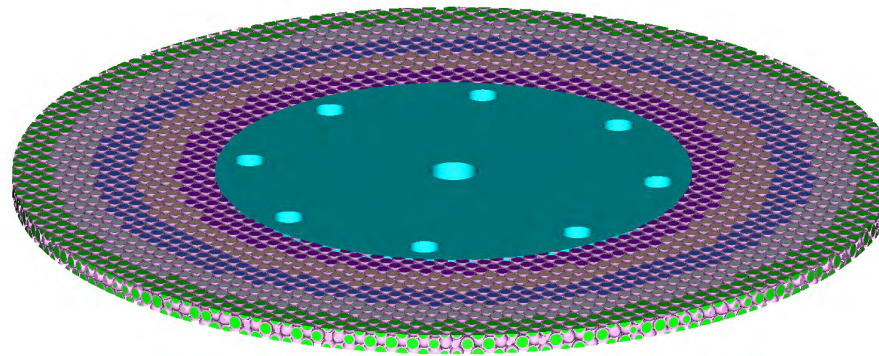

## 5. ORIGEN library development: “reflected plane” model

- Accounts for important radial effects
  - Proximity to reflector
  - Effects of nearest neighbor pebbles
- Can easily be tuned for different axial zones

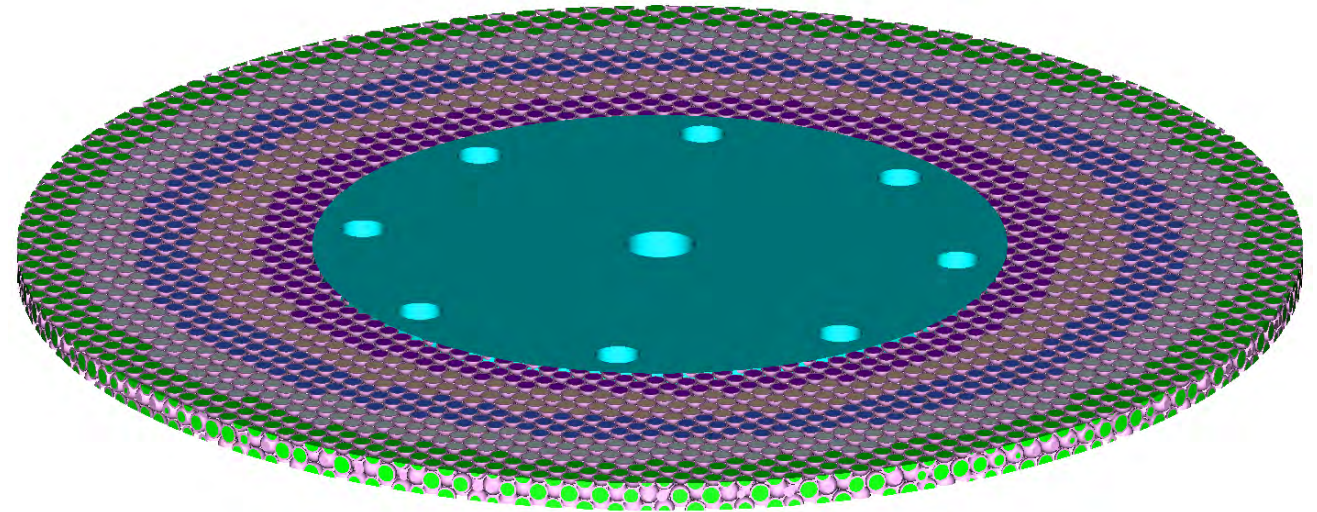

# 5. Plane model captures important neighbor effects

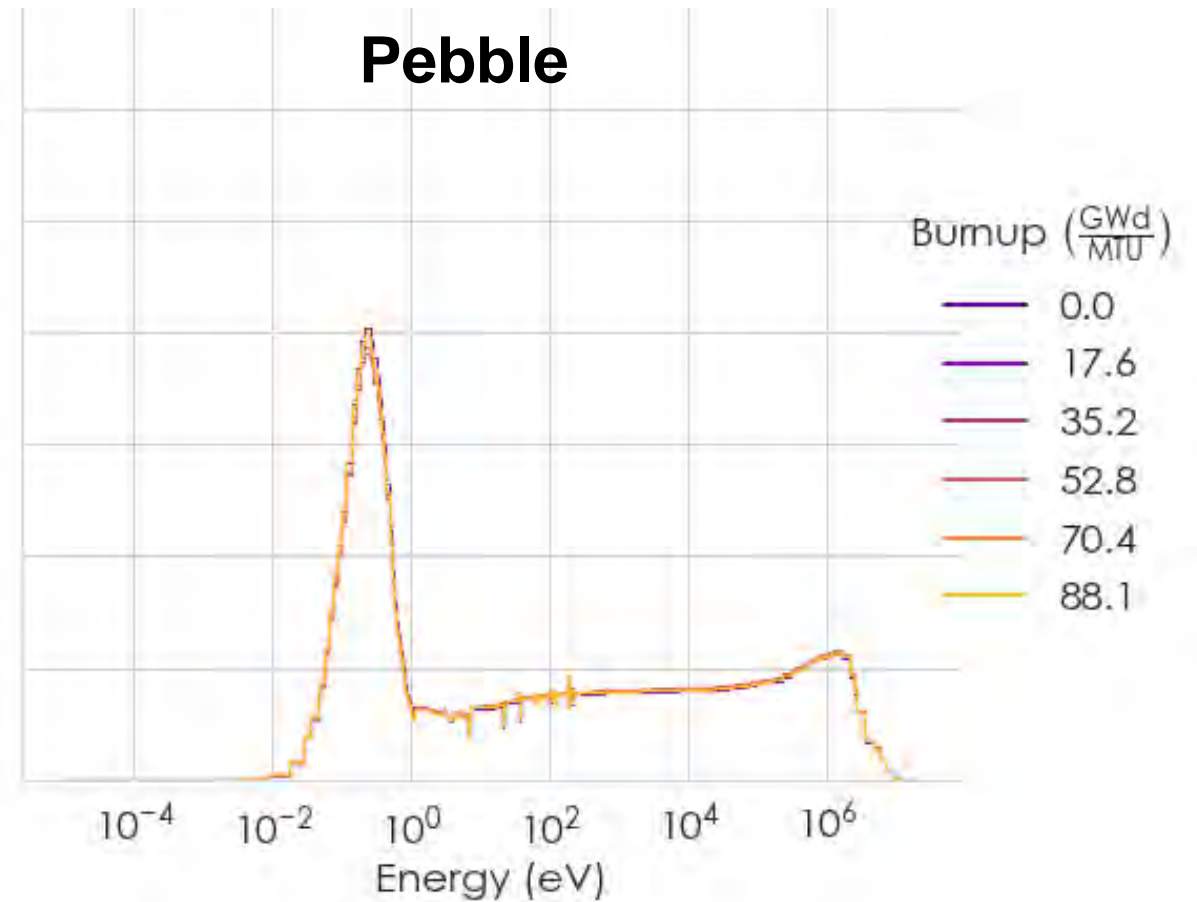
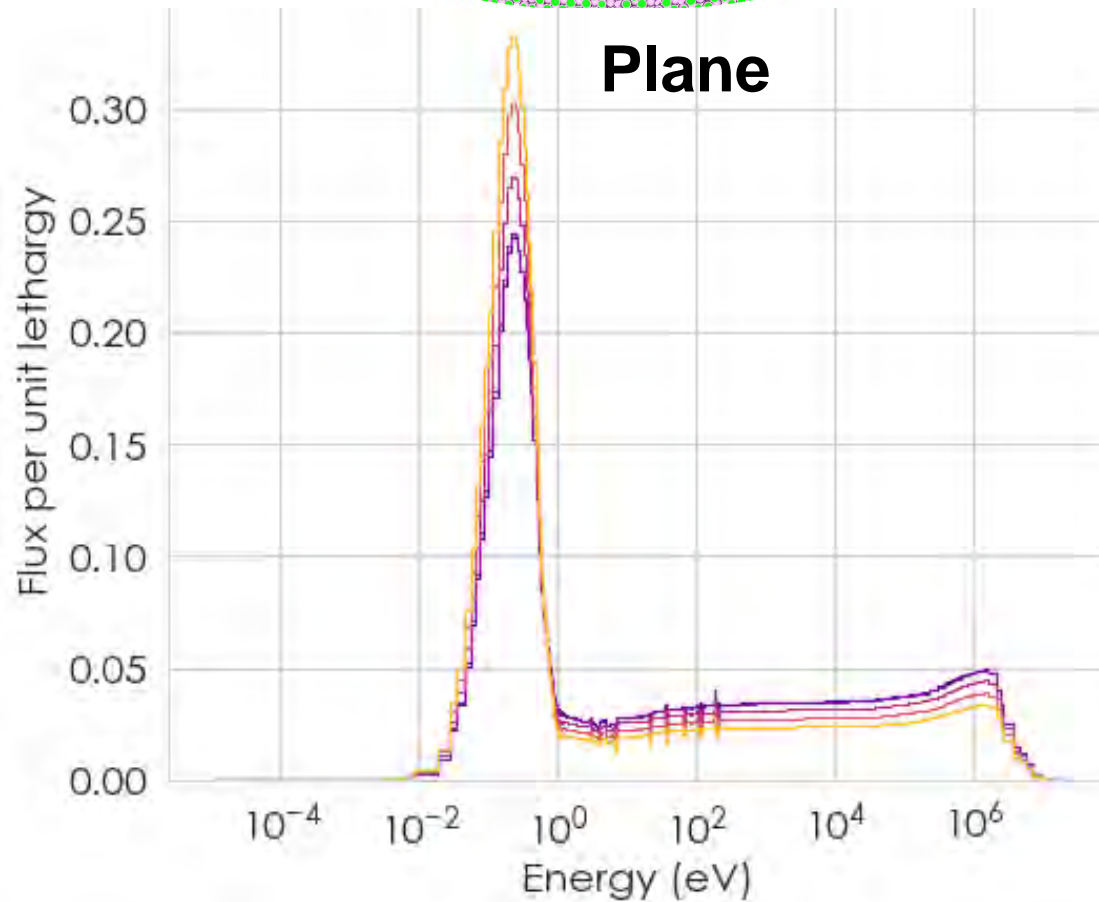
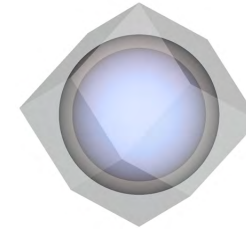
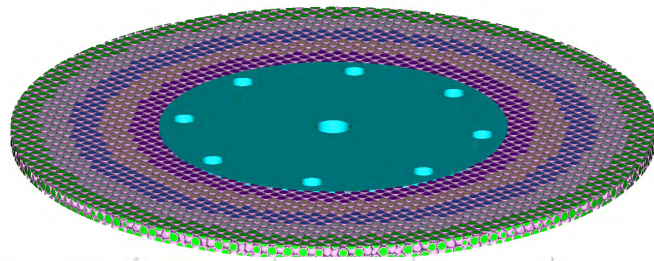

# 5. ORIGEN library generation based on 5 spectral zones

- Five separate cases constructed starting with a fresh pebble surrounded by non-depleting neighbors with compositions derived from PBMR-400 benchmark inventory ND-Set3
- Pebble depleted to discharge burnup surrounded by invariant neighbors

rzone=1

rzone=2

rzone=3

rzone=4

rzone=5

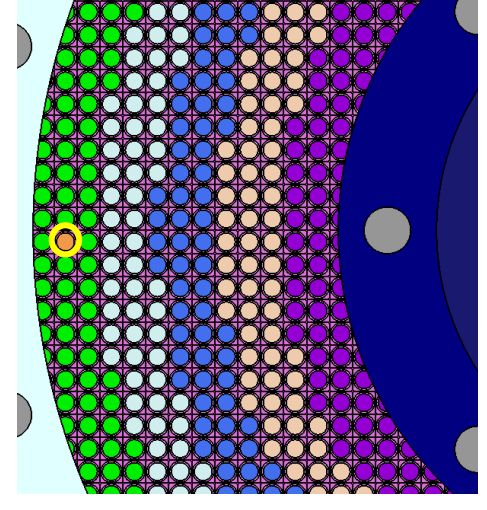
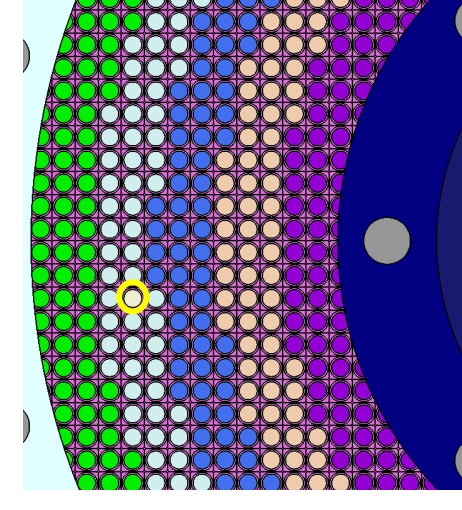
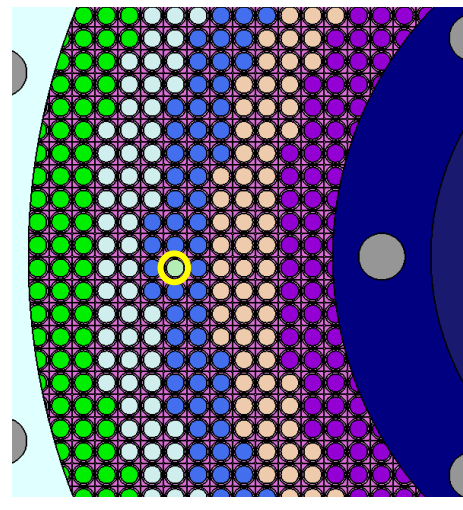
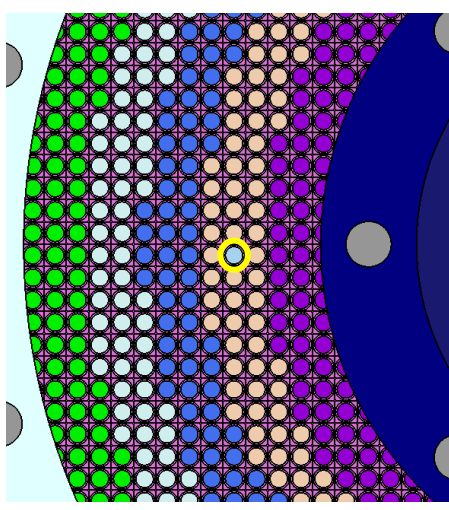
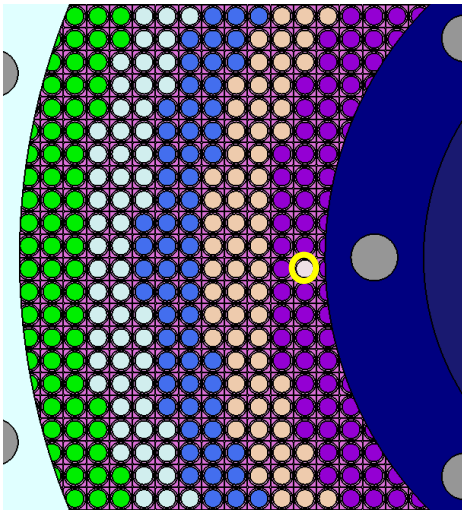

# 5. Radial, temperature effects drive differences in 1-group XS's ORIGEN libraries

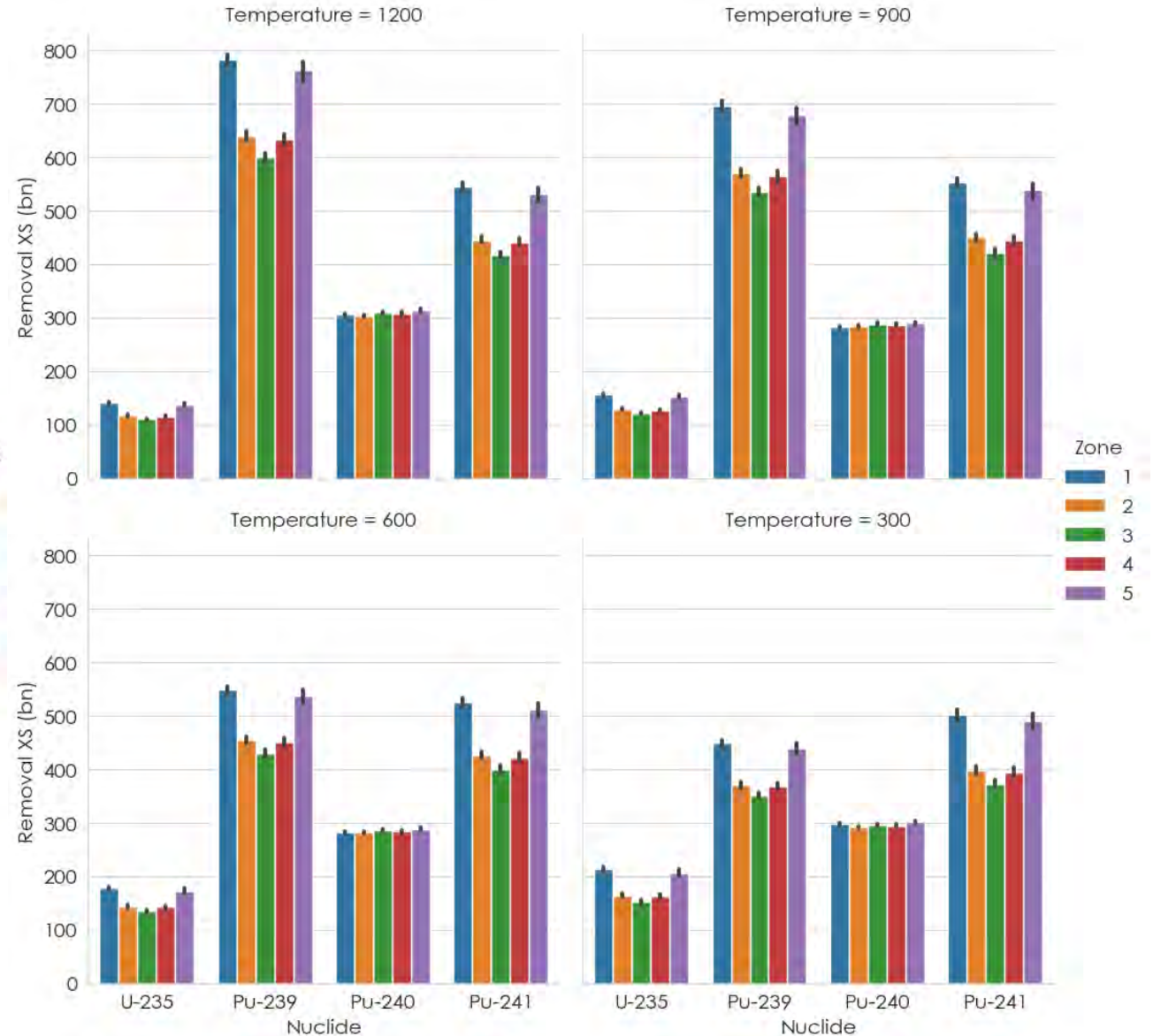
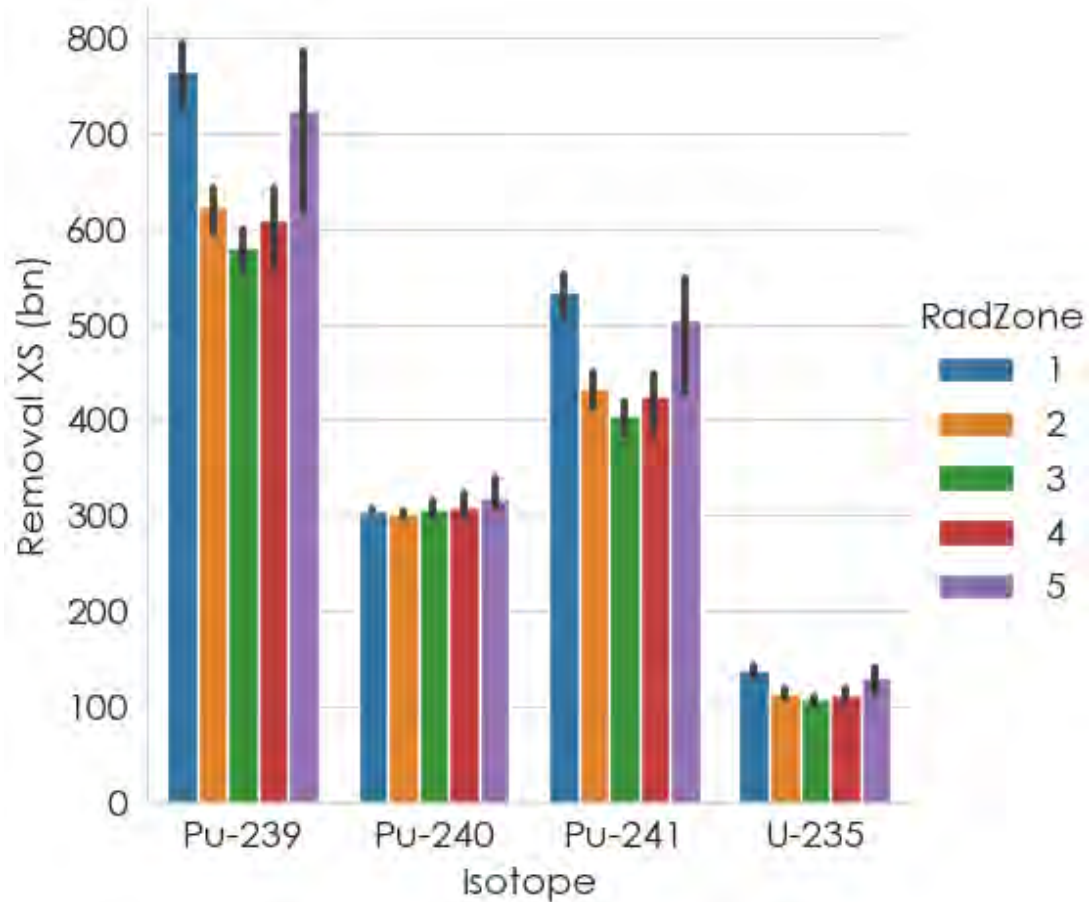

# 5. Radial zone effects far more prevalent than burnup effects for pebble bed depletion

Spatial-driven differences in loss cross-sections relatively stable over burnup

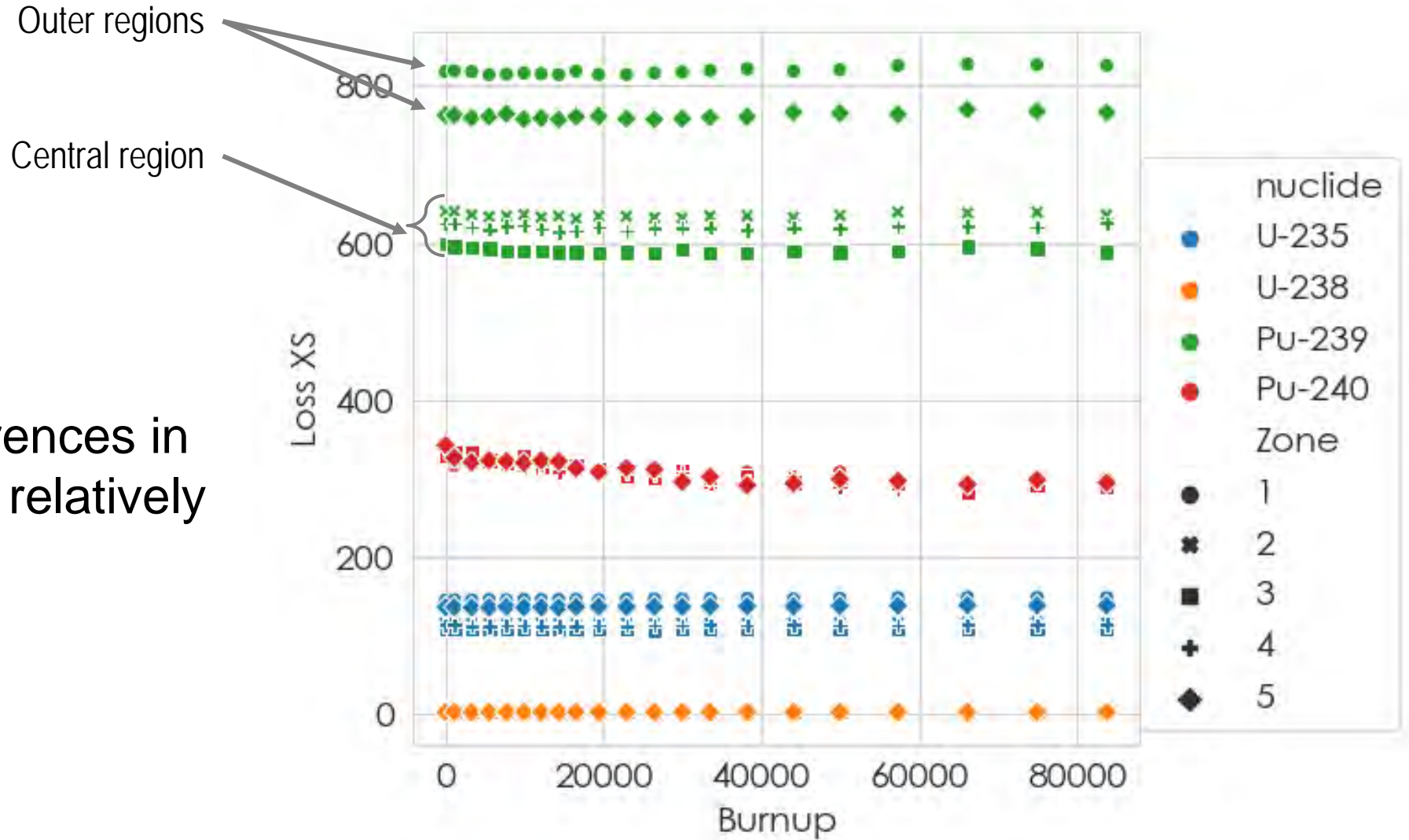

# 5. Temperature (system isotherm) shows a large, region-dependent effect on 1G removal XS

Magnitude of XS differences due to radial location **increases with system temperature**

- Gap between “inner” and “outer” regions grows with increasing temperature
- Implies a covariant relationship between location & temperature

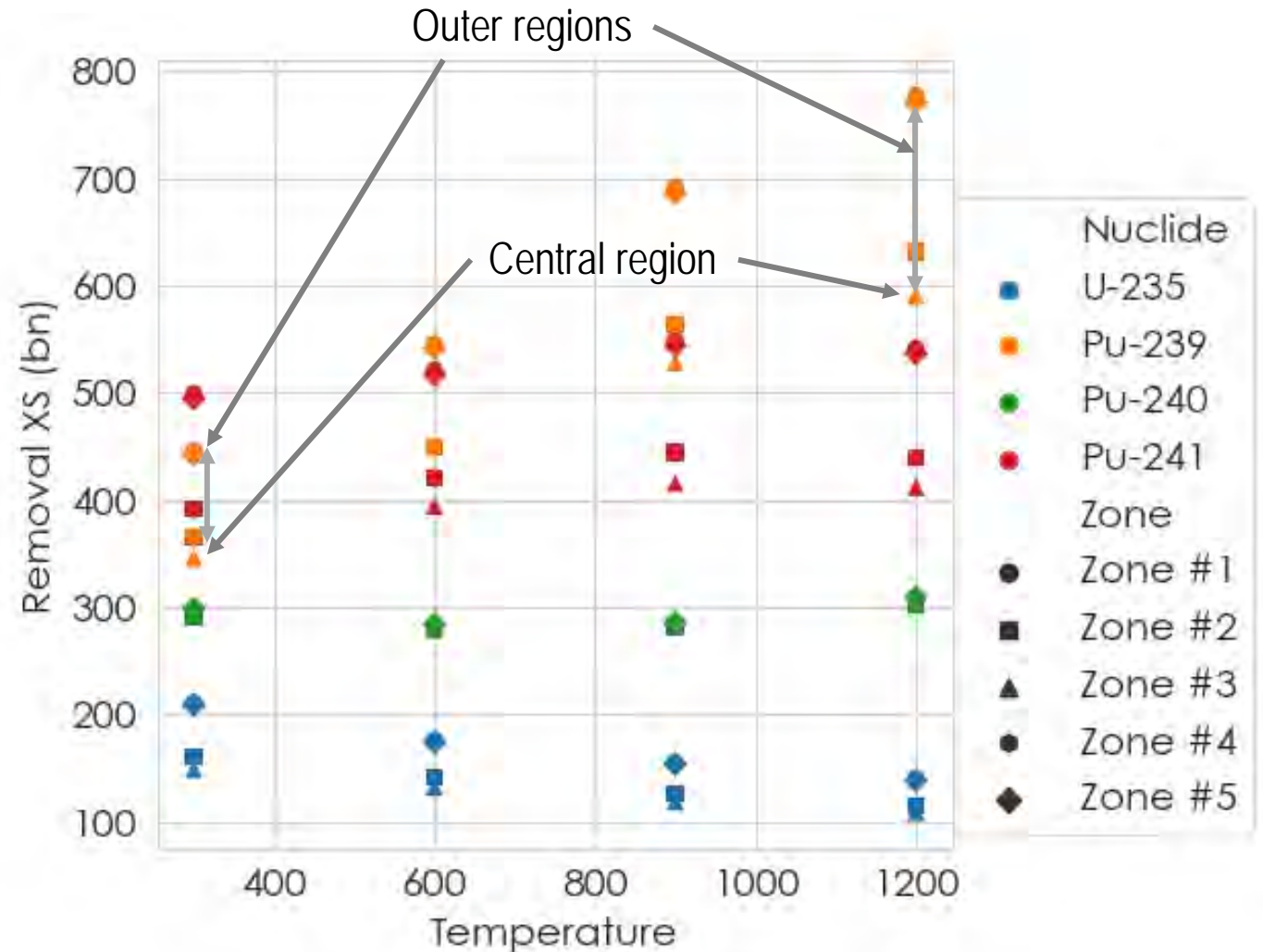



# Conclusions for pebble bed reactor ORIGEN library development

- Analysis areas
  1. Pebble packing
  2. Temperature feedback
  3. Radial/axial spectral variation
  4. Pebble flow
  5. TRITON model scope for ORIGEN library generation
- For ORIGEN library generation
  - Burnup effects appear to be second-order, roughly linear in nature
  - Radial distance from the reflector is a first-order spectrum characteristic
    - Must be accounted for in library generation
  - Temperature (system isotherm) also a first-order effect
    - Shows covariance with radial position
    - Driven primarily by graphite (reflector) temperature

## Further details:

S. Skutnik, W. Wieselquist, "Assessment of ORIGEN Reactor Library Development for Pebble-Bed Reactors Based on the PBMR-400 Benchmark," ORNL/TM-2020/1886, July 2021  
*Available on [osti.gov](https://www.osti.gov)*

# MELCOR High-Temperature Gas-Cooled Reactor Model



**U.S. NRC**



**Sandia  
National  
Laboratories**

# MELCOR HTGR modeling

## Fission product release

- Release from TRISO kernel
- Radionuclide distributions within the layers in the TRISO particle and compact
- Release to coolant

## Other core models

- Graphite oxidation
- Intercell and intracell conduction
- Convection & flow
- Point kinetics
- Dust generation and resuspension

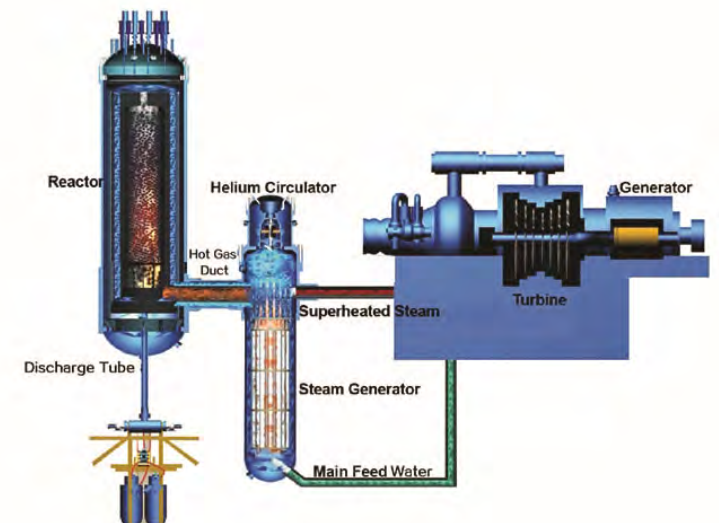
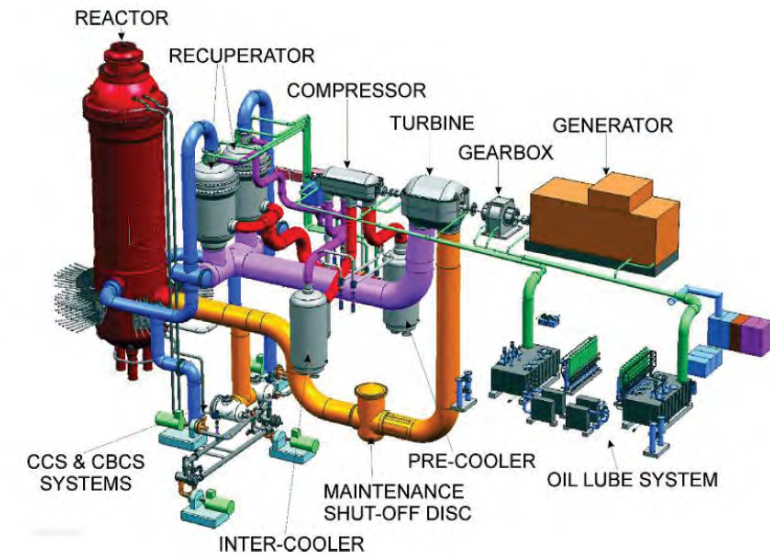

# HTGR Components

## • Pebble Bed Reactor Fuel/Matrix Components

- Fueled part of pebble
- Unfueled shell (matrix) is modeled as separate component
- Fuel radial temperature profile for sphere

Fueled pebble core

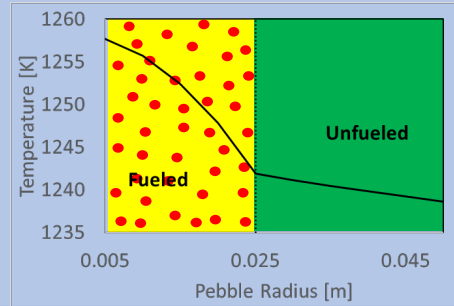
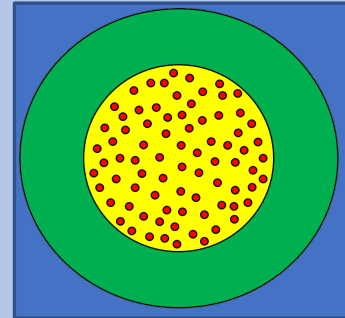

Unfueled pebble core

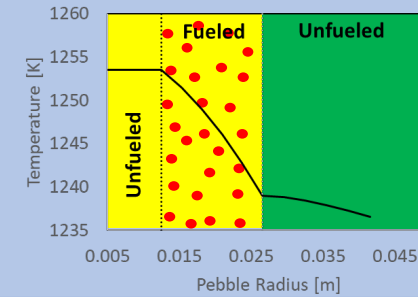
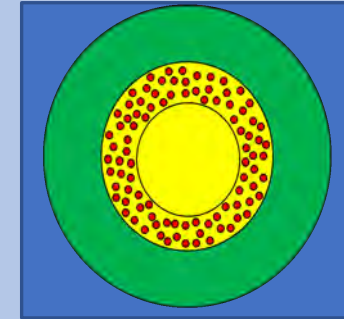

## Legend

	TRISO	} Fuel (FU)
	GRAPHITE	
	GRAPHITE	Matrix (MX)
		Fluid B/C



TRISO (FU)

*Sub-component model for zonal diffusion of radionuclides through TRISO particle*

## • Prismatic Modular Reactor Fuel/Matrix Components

- “Rod-like” geometry
- Part of hex block associated with a fuel channel is matrix component
- Fuel radial temperature profile for cylinder

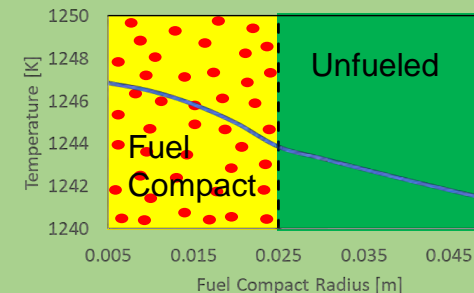
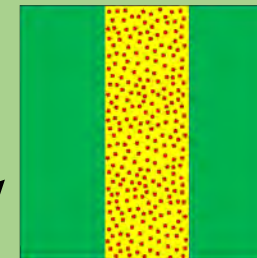
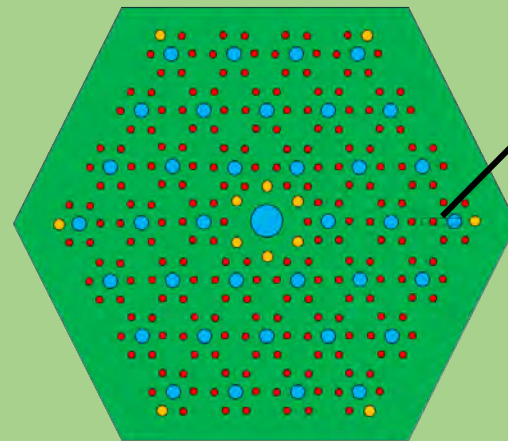

# Transient/Accident Solution Methodology

**Stage 0:**  
Normal Operation  
Establish thermal state

*Time constant in HTGR graphite structures is very large*

*Reduce heat capacities for structures to reach steady state thermal conditions.*

*Reset heat capacities after steady state is achieved.*

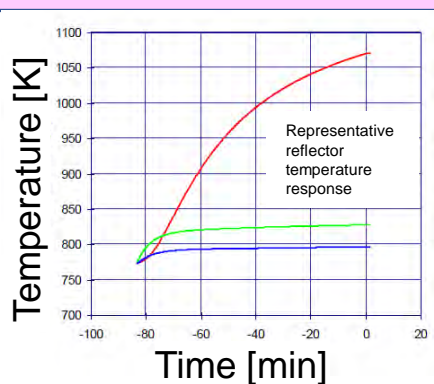

**Stage 1:**  
Normal Operation  
Diffusion Calculation

*Establish steady state distribution of radionuclides in TRISO particles and matrix*

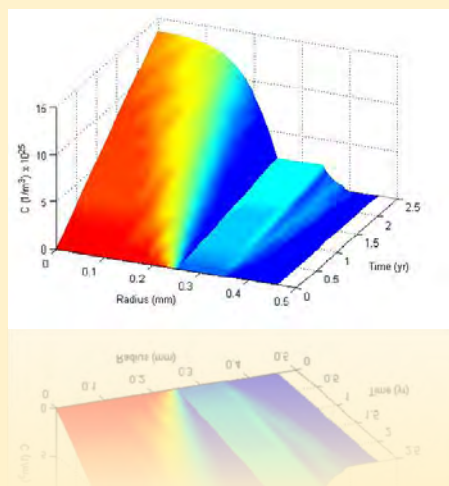

**Stage 2:**  
Normal Operation  
Transport Calculation

*Calculate steady state distribution of radionuclides and graphite dust throughout system (deposition on surfaces, convection through flow paths)*

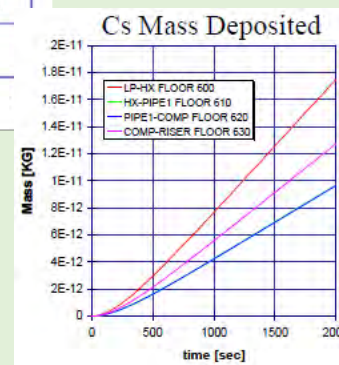
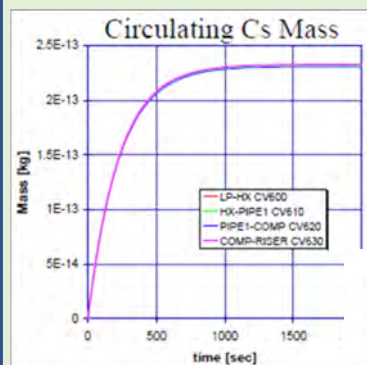

Example:  
PBMR-400 Cs  
Distribution in  
Primary  
System

**Stage 3:**  
Accident  
Diffusion & Transport calculation

*Calculate accident progression and radionuclide release*

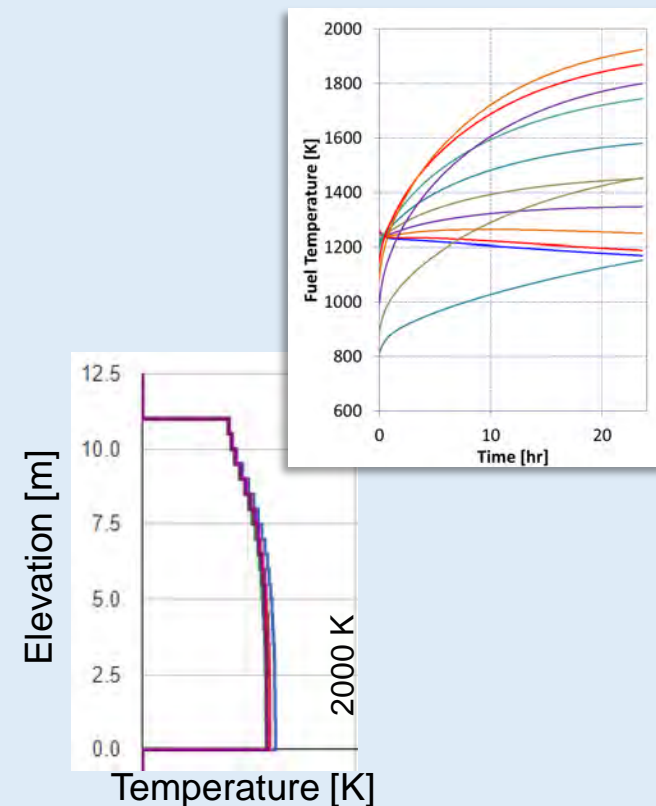

# HTGR Radionuclide Diffusion Release Model

## Intact TRISO Particles

- One-dimensional finite volume diffusion equation solver for multiple zones (materials)
- Temperature-dependent diffusion coefficients (Arrhenius form)

$$\frac{\partial C}{\partial t} = \frac{1}{r^n} \frac{\partial}{\partial r} \left( r^n D \frac{\partial C}{\partial r} \right) - \lambda C + \beta \quad D(T) = D_0 e^{-\frac{Q}{RT}}$$

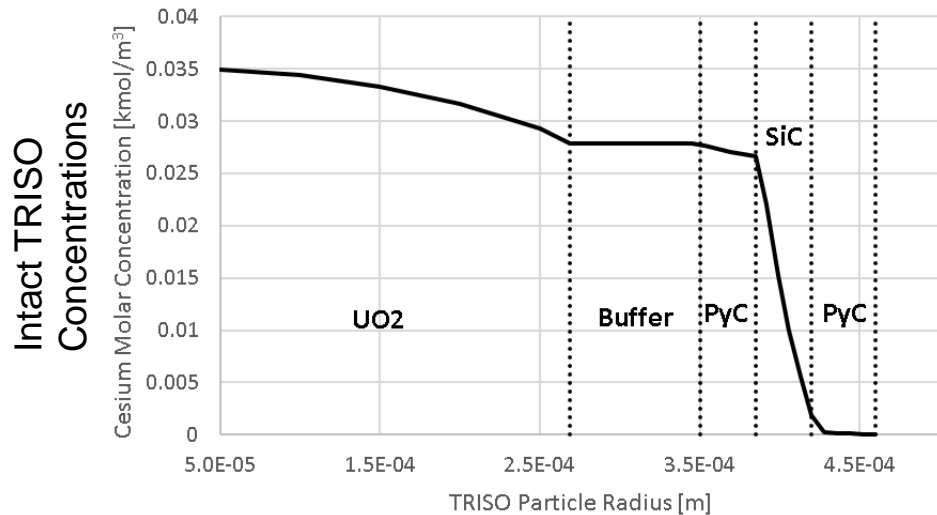
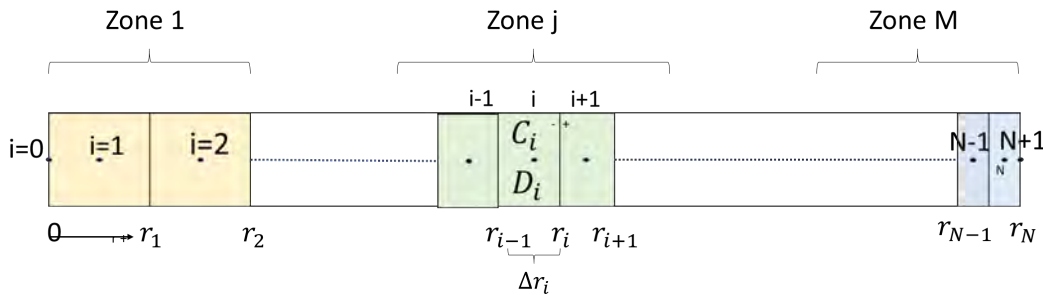

## Diffusivity Data Availability

Radionuclide	UO <sub>2</sub>	UCO	PyC	Porous Carbon	SiC	Matrix Graphite	TRISO Overall	
Ag	Some	Not investigated	Some	Not found	Extensive	Some	Extensive	
Cs	Some		Some		Extensive	Some	Some	
I	Some		Some		Some	Not found	Not found	Not found
Kr	Some		Some		Not found	Some	Some	Some
Sr	Some		Some		Extensive	Some	Some	Some
Xe	Some		Some		Some	Some	Some	Not found

## Data used in the demo calculation [IAEA TECDOC-0978]

Layer	FP Species							
	Kr		Cs		Sr		Ag	
	D (m <sup>2</sup> /s)	Q (J/mole)	D (m <sup>2</sup> /s)	Q (J/mole)	D (m <sup>2</sup> /s)	Q (J/mole)	D (m <sup>2</sup> /s)	Q (J/mole)
Kernel (normal)	1.3E-12	126000.0	5.6E-8	209000.0	2.2E-3	488000.0	6.75E-9	165000.0
Buffer	1.0E-8	0.0	1.0E-8	0.0	1.0E-8	0.0	1.0E-8	0.0
PyC	2.9E-8	291000.0	6.3E-8	222000.0	2.3E-6	197000.0	5.3E-9	154000.0
SiC	3.7E+1	657000.0	7.2E-14	125000.0	1.25E-9	205000.0	3.6E-9	215000.0
Matrix Carbon	6.0E-6	0.0	3.6E-4	189000.0	1.0E-2	303000.0	1.6E00	258000.0
Str. Carbon	6.0E-6	0.0	1.7E-6	149000.0	1.7E-2	268000.0	1.6E00	258000.0

Iodine assumed to behave like Kr

CORSOR-Booth LWR scaling used to estimate other radionuclides

# HTGR Radionuclide Release Models

- Recent failures – particles failing within latest time-step (burst release, diffusion release in time-step)
- Previous failures – particles failing on a previous time-step (time history of diffusion release)
- Contamination and recoil

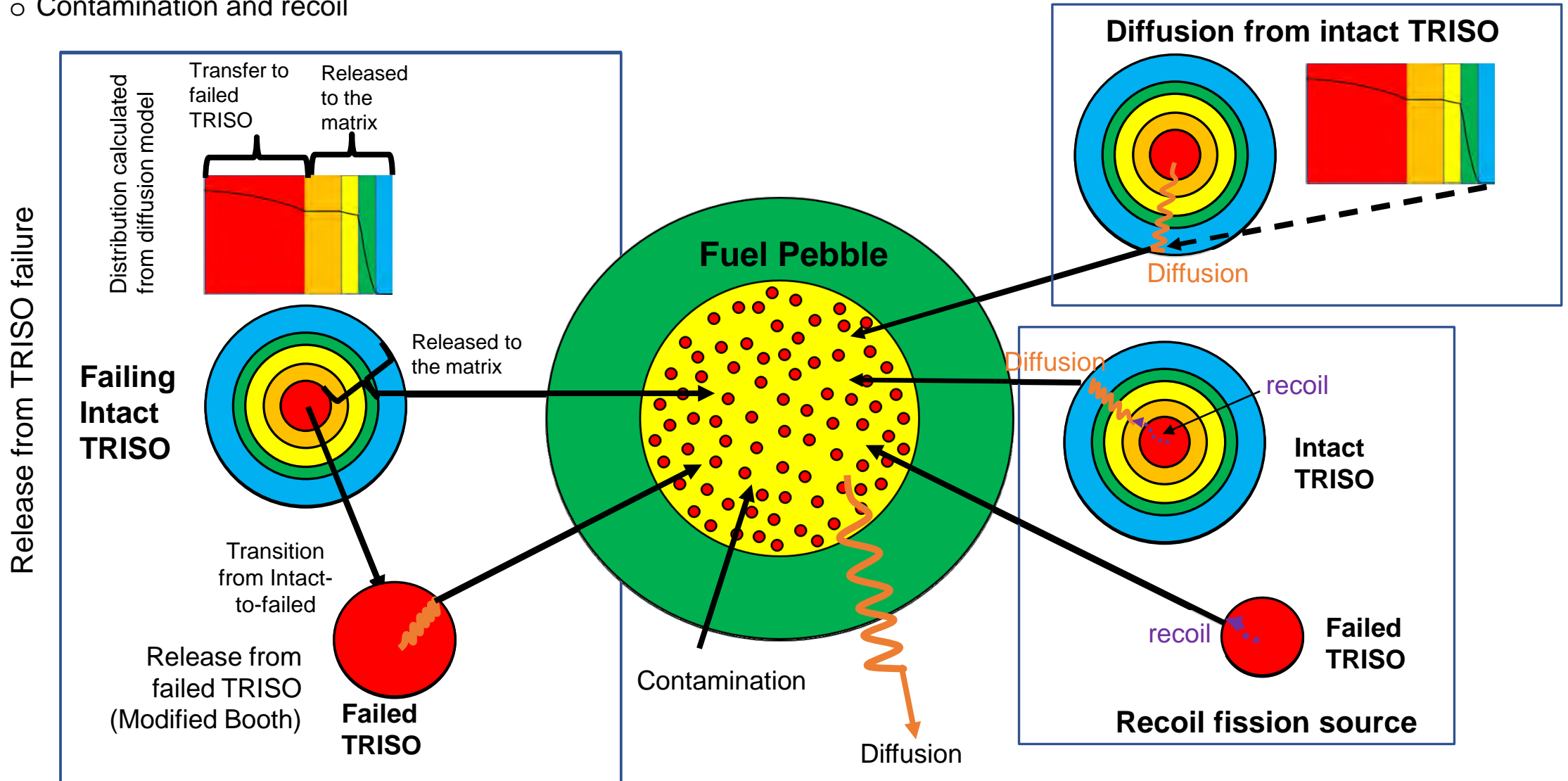

# Graphite Oxidation

## Steam oxidation

$$R_{OX, steam} = \frac{k_4 P_{H_2O}}{1 + k_5 P_{H_2}^{0.5} + k_6 P_{H_2O}}$$

## Air oxidation

$$R_{OX} = 1.7804 \times 10^4 \exp\left(-\frac{20129}{T}\right) \left(\frac{P}{0.21228 \times 10^5}\right)^{0.5}$$

## Reactions

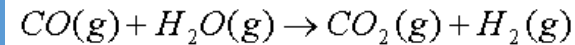
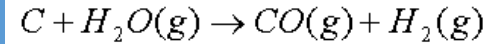

## Reactions

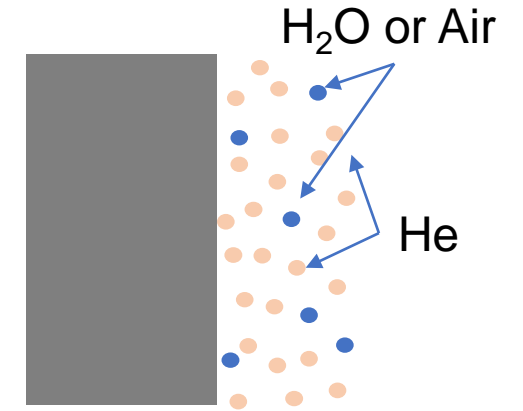
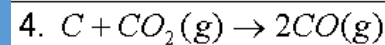
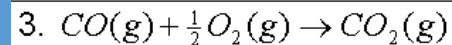
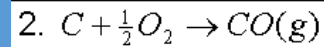
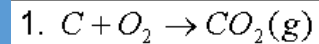

Both steam and air include rate limit due to steam/air diffusion towards active oxidation surface

$R_{OX}$  is the rate term in the parabolic oxidation equation [1/s]



# COR Intercell Conduction

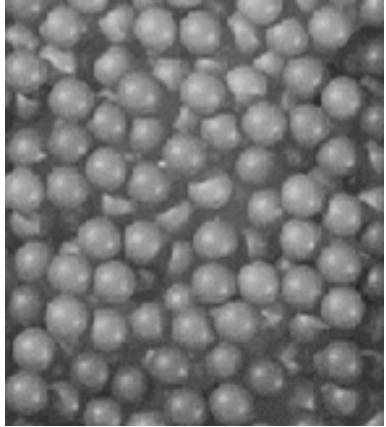

## Effective conductivity prescription for pebble bed (bed conductance)

- Zehner-Schlunder-Bauer with Breitbach-Barthels modification to the radiation term

$$k_{eff} = (1 - \sqrt{1 - \epsilon}) \epsilon 4 \sigma T^3 D_p + (1 - \sqrt{1 - \epsilon}) k_f + \sqrt{1 - \epsilon} k_c(T, D_p, \epsilon, k_f, k_s, k_r)$$

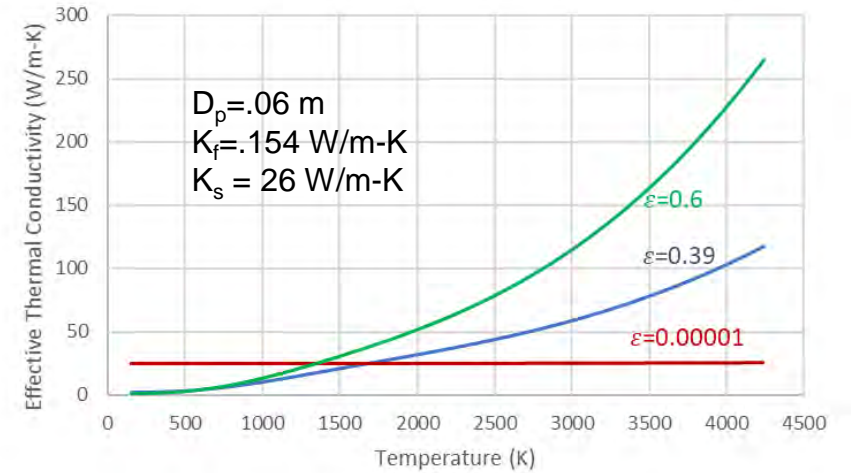

## Effective conductivity prescription for prismatic (continuous solid with pores)

- Tanaka and Chisaka expression for effective radial conductivity (of a single PMR hex block)

$$k_{eff} = k_s \left[ A + (1 - A) \frac{\ln(1 + 2B(k_{por} / k_s - 1))}{2B(1 - k_s / k_{por})} \right]$$

- A radiation term is incorporated in parallel with the pore conductivity
- Thermal resistance of helium gaps between hex block fuel elements is added in parallel via a gap conductance term

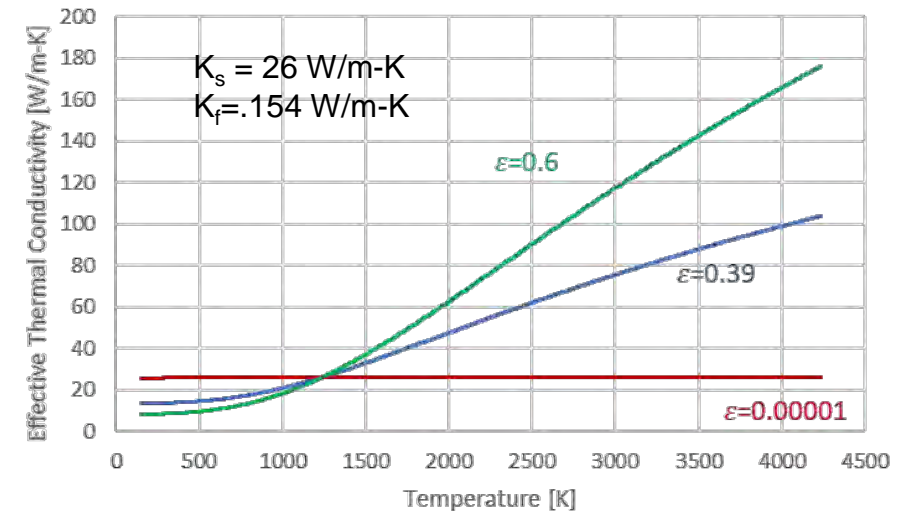

# Interface Between Thermal-hydraulics and Pebble Bed Reactor Core Structures

Heat transfer coefficient (Nusselt number) correlations for pebble bed convection:

- Isolated, spherical particles
- Use  $T_{film}$  to evaluate non-dimensional numbers, use maximum of forced and free Nu

$$Nu_{Free} = 2.0 + 0.6 Gr_f^{1/4} Pr_f^{1/3}$$

$$Nu_{Forced} = 2.0 + 0.6 Re_f^{1/2} Pr_f^{1/3}$$

- Constants and exponents accessible by sensitivity coefficient

## Flow resistance

- Packed bed pressure drop

$$K_L(\epsilon, Re) = \left[ C_1 + C_2 \frac{1-\epsilon}{Re} + C_3 \left( \frac{1-\epsilon}{Re} \right)^{C_4} \right] \frac{(1-\epsilon)L}{\epsilon D_p}$$

Correlation	C <sub>1</sub>	C <sub>2</sub>	C <sub>3</sub>	C <sub>4</sub>
Ergun (original)	3.5	300.	0.0	-
Modified Ergun (smooth)	3.6	360.	0.0	-
Modified Ergun (rough)	8.0	360.	0.0	-
Achenbach	1.75	320.	20.0	0.4

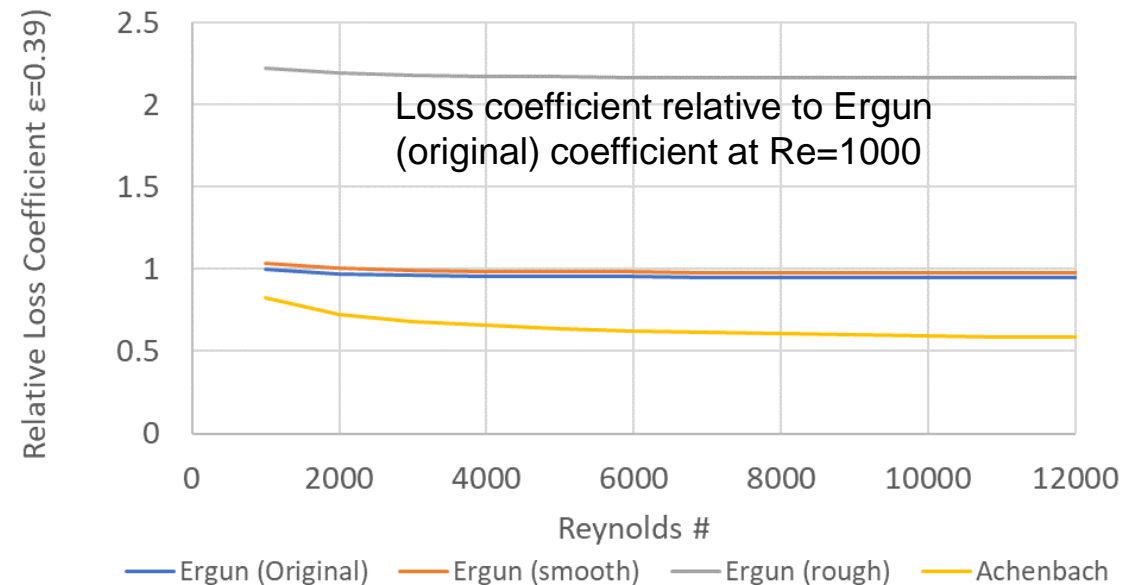

# Point kinetics modeling

## Standard treatment

$$\frac{dP}{dt} = \left( \frac{\rho - \beta}{\Lambda} \right) P + \sum_{i=1}^6 \lambda_i Y_i + S_0$$

$$\frac{dY_i}{dt} = \left( \frac{\beta_i}{\Lambda} \right) P - \lambda_i C_i, \quad \text{for } i = 1 \dots 6$$

## Feedback models

- User-specified external input
- Doppler
- Fuel and moderator density

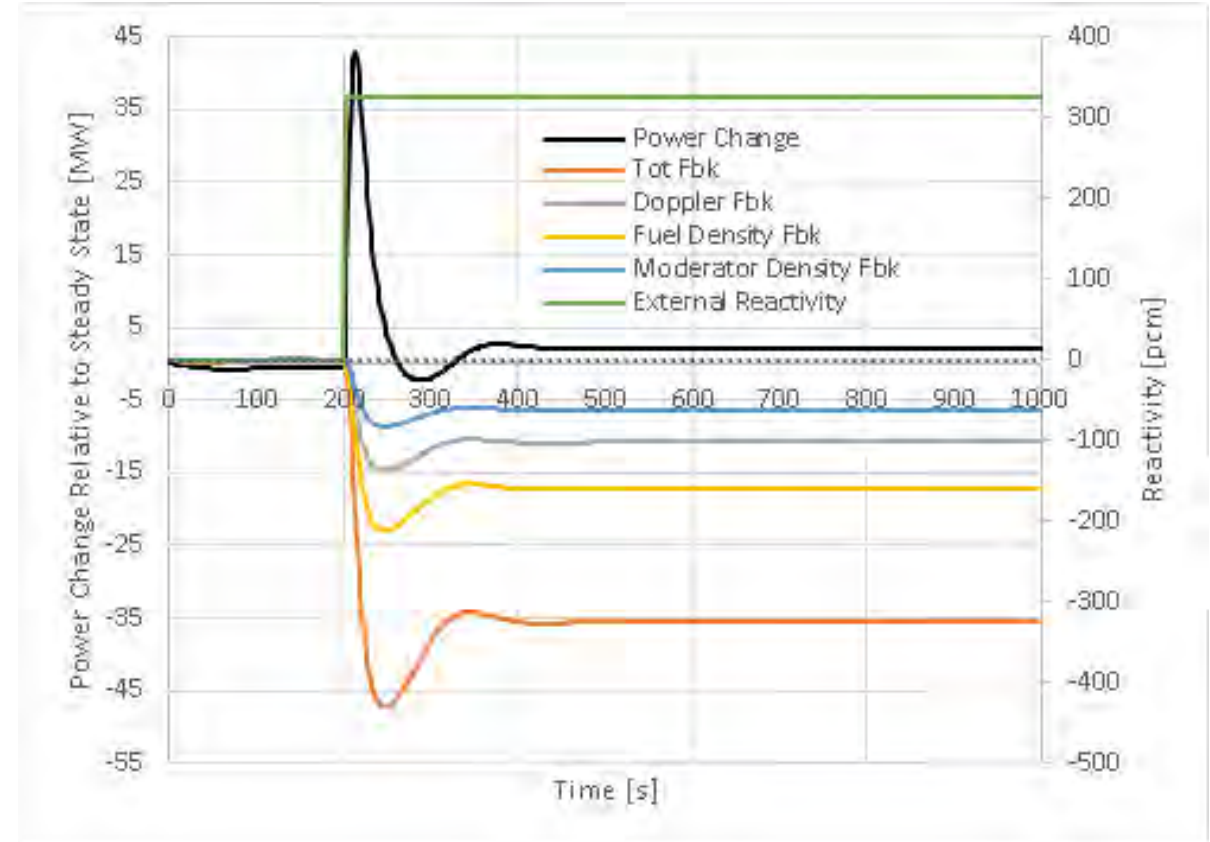

# High-Temperature Gas-Cooled Reactor Plant Model and Source Term Analysis



**U.S. NRC**



# Reactor vessel and core

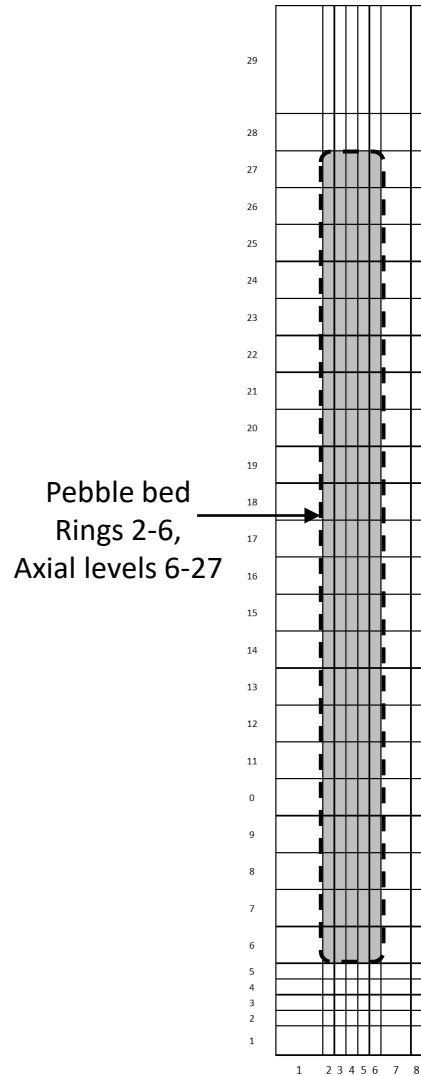

Vessel core package nodalization  
(8 rings x 29 axial levels)  
Correct aspect ratio

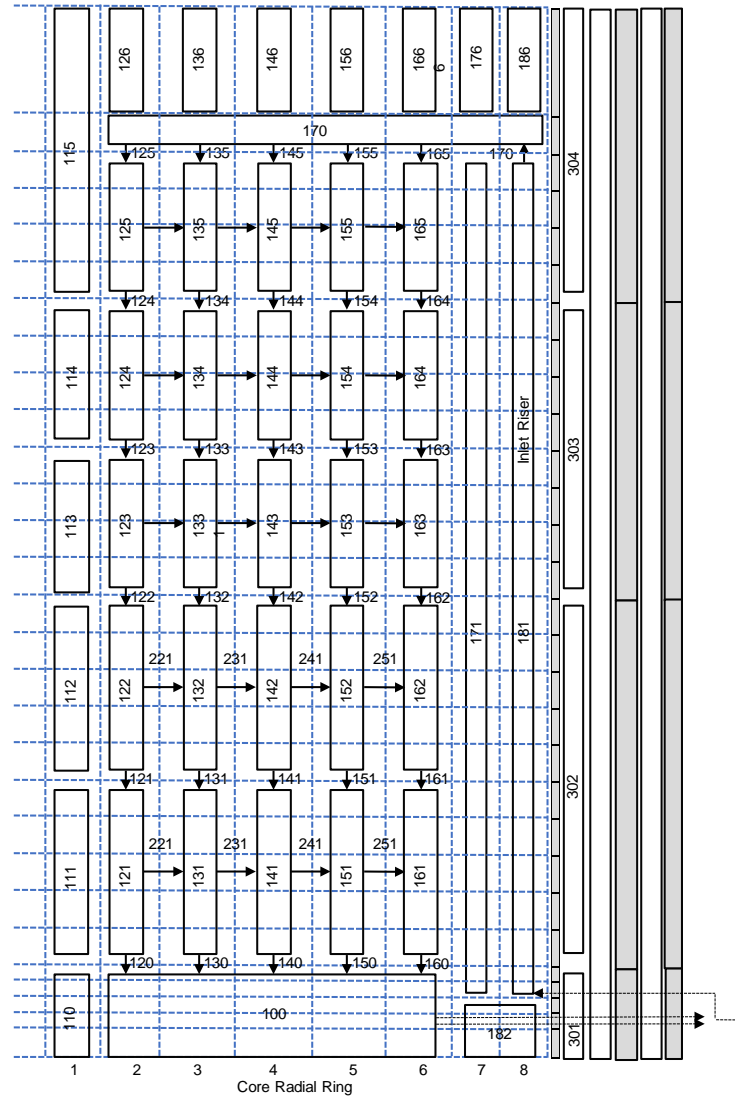

Vessel control volume, flow path, and heat structure  
nodalization with core package boundaries in blue

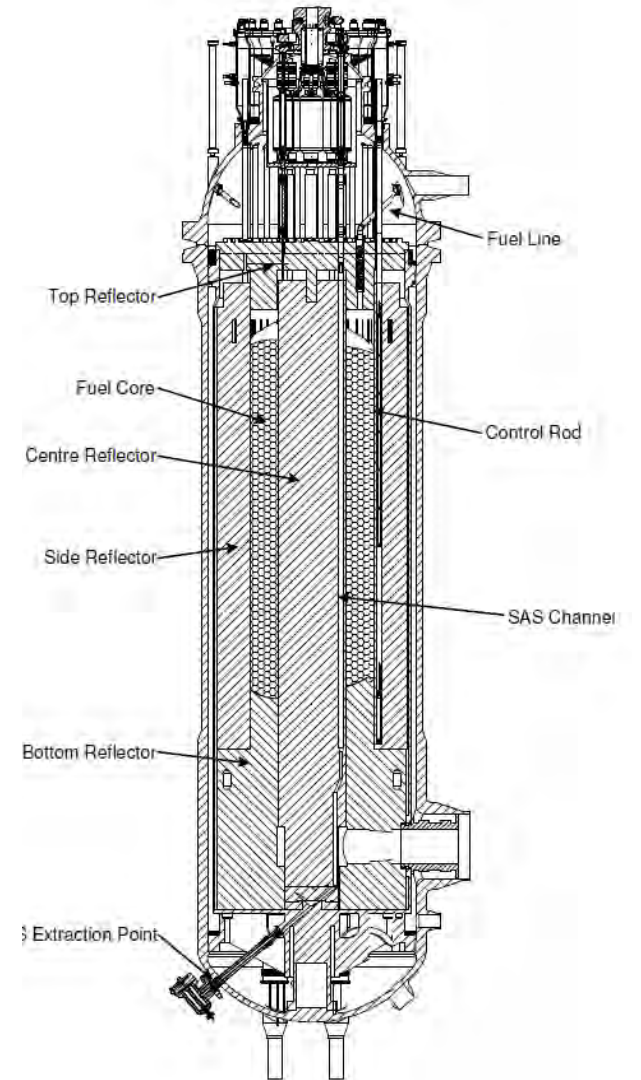

[P.J. Venter, M.N. Mitchell, F. Fortier, PBMR reactor design and development, in: Proceedings from the 18th International Conference on Structural Mechanics in Reactor Technology (SMiRT 18), Beijing, China, Aug. 2005]

# Reactor building

## Nodalization guided by NGNP layout

- Passive air-flow Reactor Cavity Cooling System (RCCS)

Leakage assumed to be the same as BWR Mark I reactor building surrounding the containment

- 100% vol/day at 0.25 psig

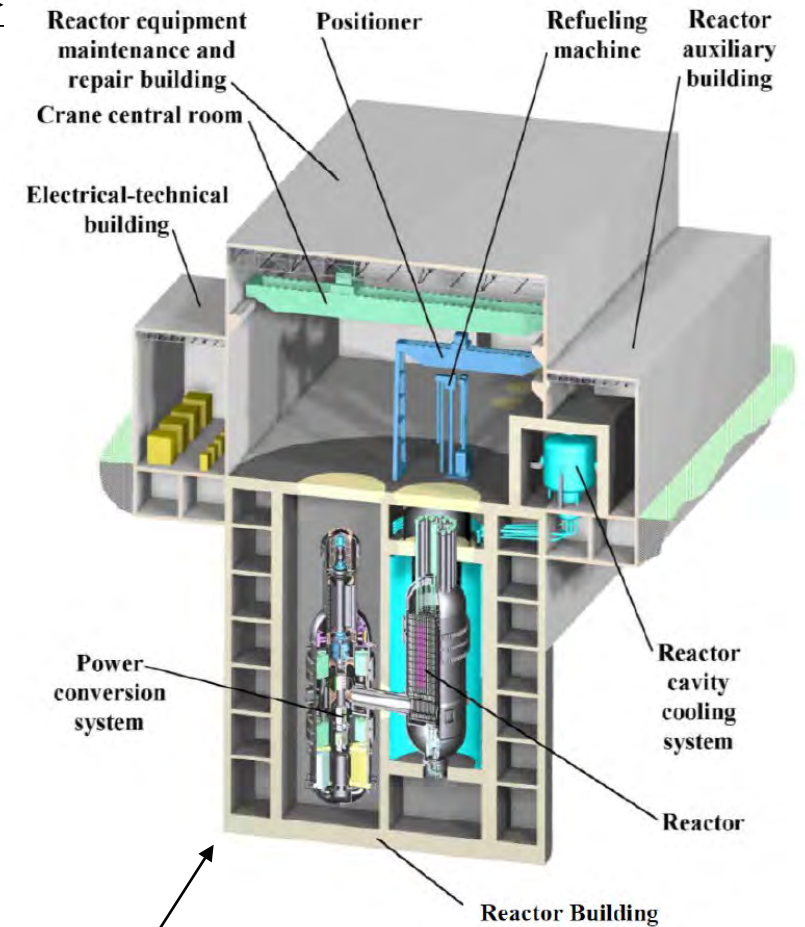
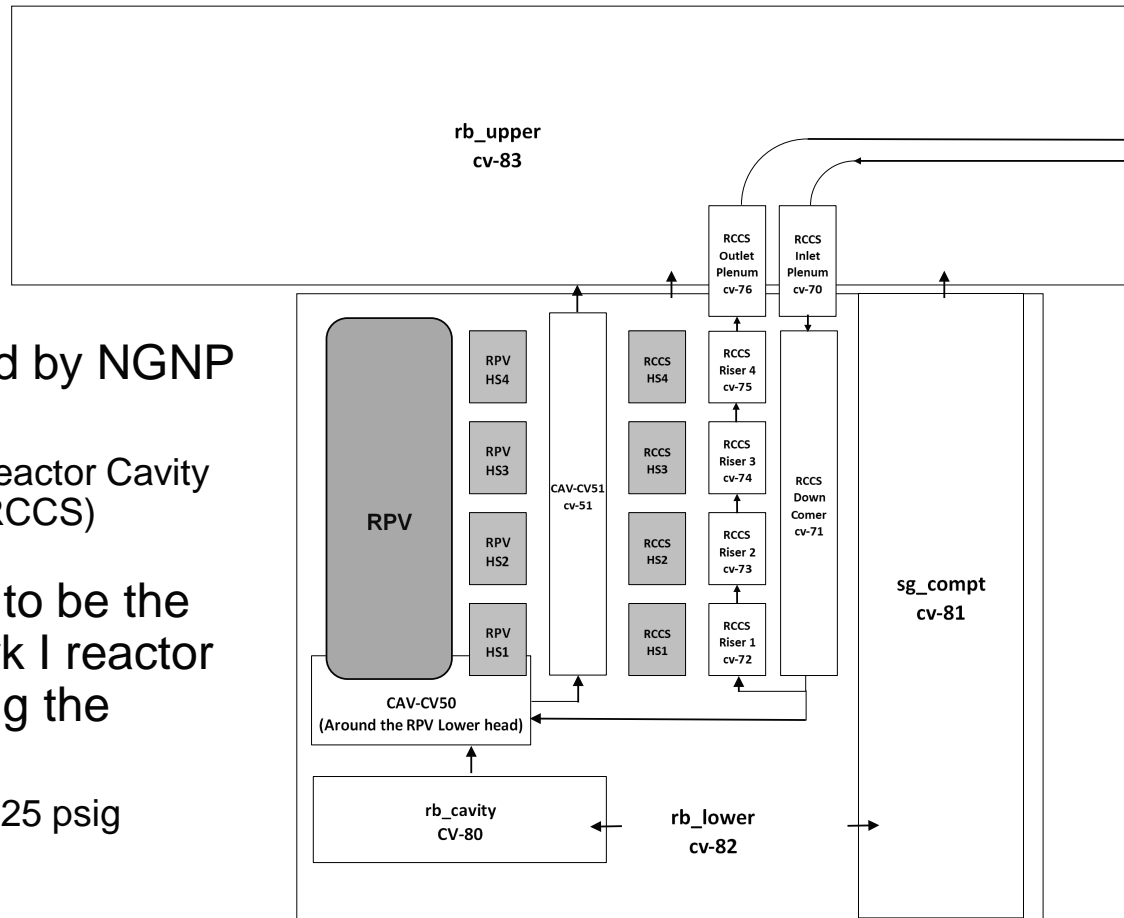

“HTGR Mechanistic Source Terms White Paper,”  
July 2010, [INL-EXT-10-17999]

Picture above shows a water-cooled RCCS but demo model uses air-cooled RCCS.

# Recirculation loop and secondary heat removal

## Recirculation system and secondary heat removal

- Recirculation loop and secondary heat removal provide boundary conditions to the vessel
  - Flow rate
  - Heat removal & inlet temperature

## Pipe break nodalization allows counter-current natural circulation flow

- MELCOR counter-current flow model used to represent adjacent stream drag forces
- Geometry similar to PWR hot leg natural circulation [NUREG-1922]
- Allows for air ingress

## Scenario: depressurized loss of forced circulation (DLOFC)

- Assumes double-ended break of the hot leg

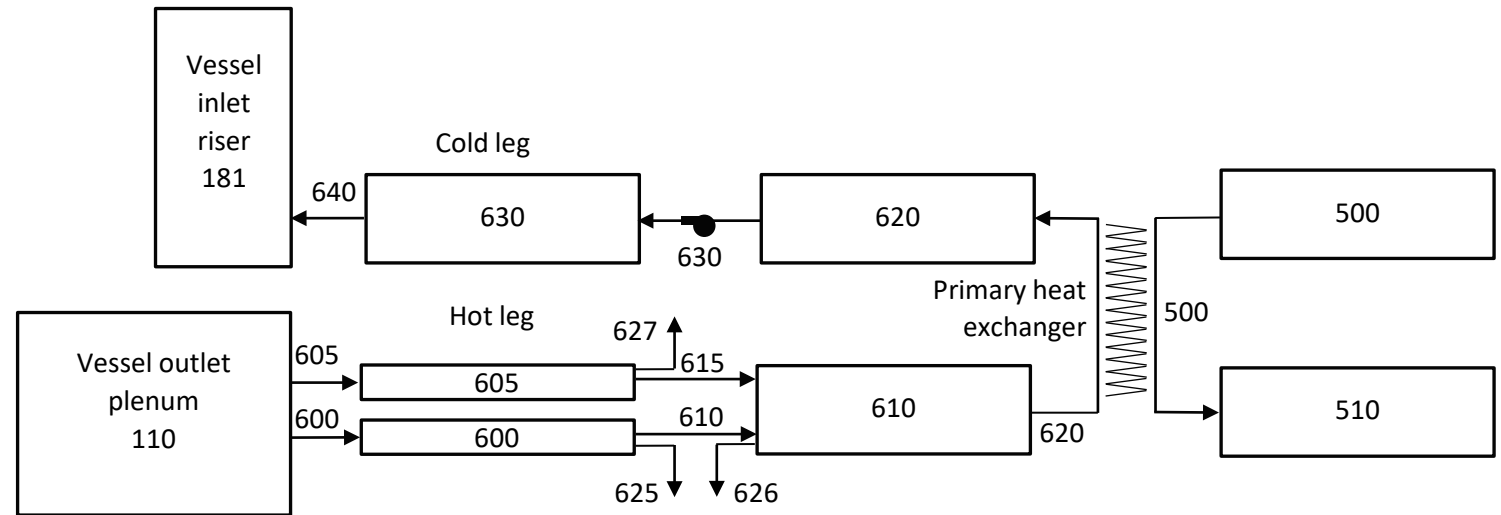

# DLOFC scenario

DLOFC is initiated after 900 days of operation

- Long-term fission product concentrations developed in TRISO and pebble
- 24 kg/yr graphite dust generation based on German AVR experience
- TRISO initialized with  $10^{-5}$  failure fraction during the steady state

Provisions for air ingress

Reactor cavity cooling system (RCCS) is operational

Individual sensitivity calculations to explore variations in the model response to uncertainty in input parameters



# DLOFC reference case results (1/7)

Following pipe break

- Control rods insert to terminate fission
- The vessel depressurizes in seconds as the high-pressure helium escapes out both sides of the broken pipe
- Peak velocity in the pebble bed is 45 m/s (normal flow rate is 11-18 m/s)

Counter-current flow established on the vessel side of the pipe break

- Hot gases from the exit plenum escape on the top side of the broken hot leg pipe and cooler gases enter along the bottom of the pipe

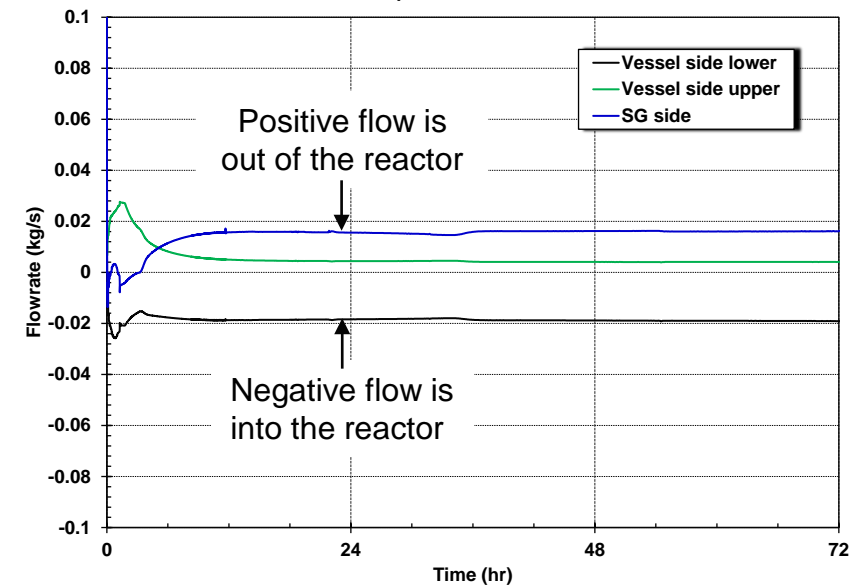
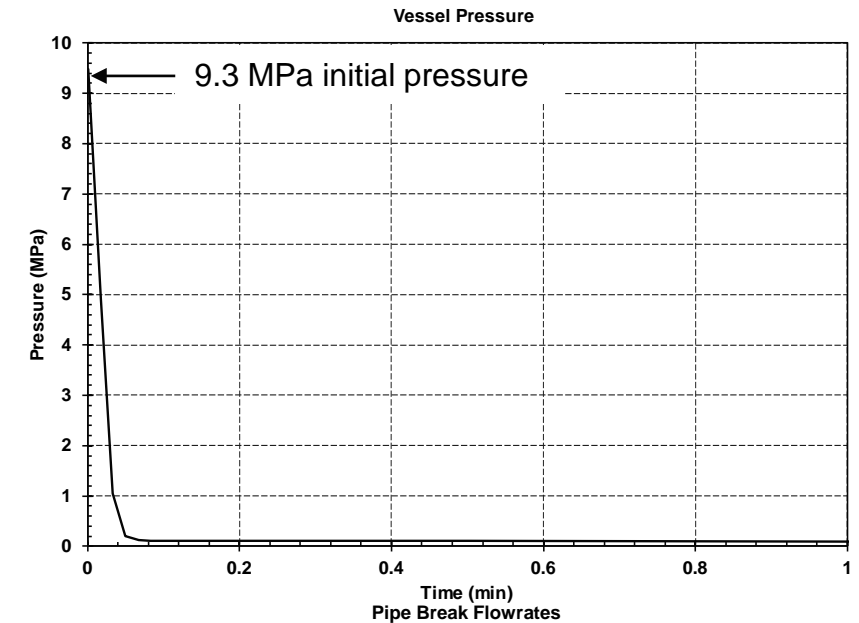

# DLOFC reference case results (2/7)

## In-vessel natural circulation flow after blowdown

- Upward flow in the inner region of the core where the fuel temperatures and decay power heating are higher
- Downward flow in the outer region of the core where the fuel temperatures and decay power heating are lower
- Flow increases when the fuel starts to cool

The fuel temperatures in the inner region of the pebble bed shift from cooler at inlet and hot at the outlet due to the flow reversal

- The axial fuel temperatures are affected by the local decay heat power (highest in the center) and the flow direction
  - During normal operation, the fuel at the exit (bottom) is the hottest
  - The exit becomes the coolest location (low power and cooler gases entering from the exit plenum)

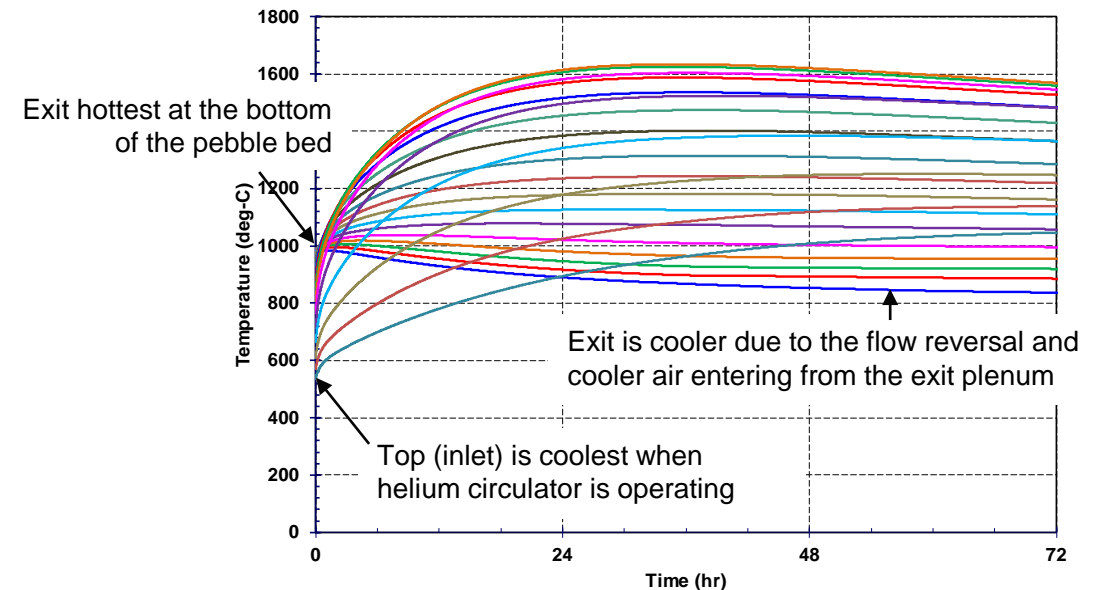
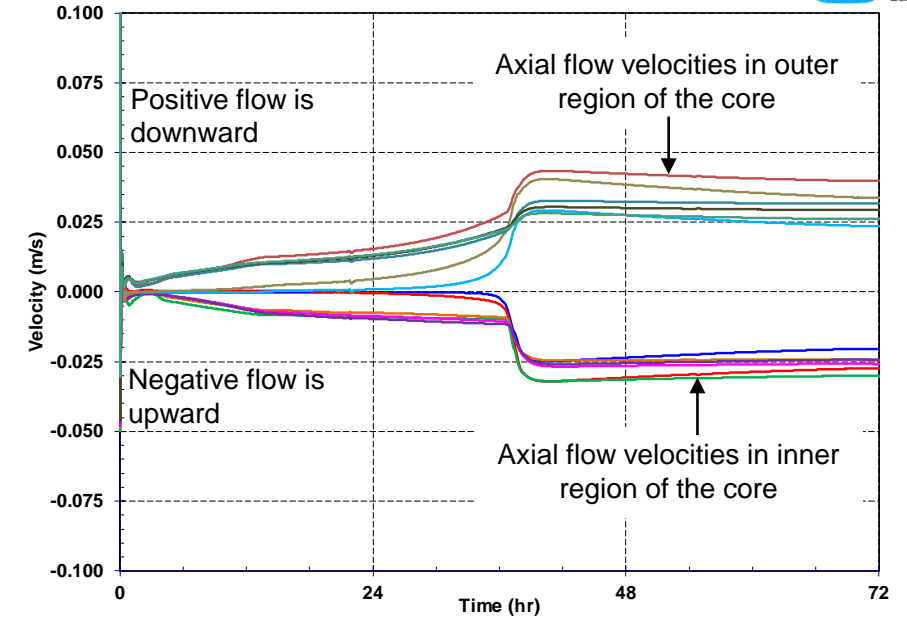

# DLOFC reference case results (3/7)

The core heatup is dominated by the decay heat

- The air oxidation power is relatively small at <25 kW
- Although the vessel is thermally-stratified with a low exit path, a small natural circulation flow persists to bring air into the vessel
  - Pebble bed inlet and circulation velocities are <0.04 m/s

The graphite oxidation produces significant quantities of CO and CO<sub>2</sub>

- Approximately 50% of the oxidation occurs in the graphite reflector structures around the inlet plenum and 50% in the lower portion of the pebble bed.
- ~1% of the pebble matrix oxidized after 168 hr
  - 17% peak pebble oxidation at the bottom center

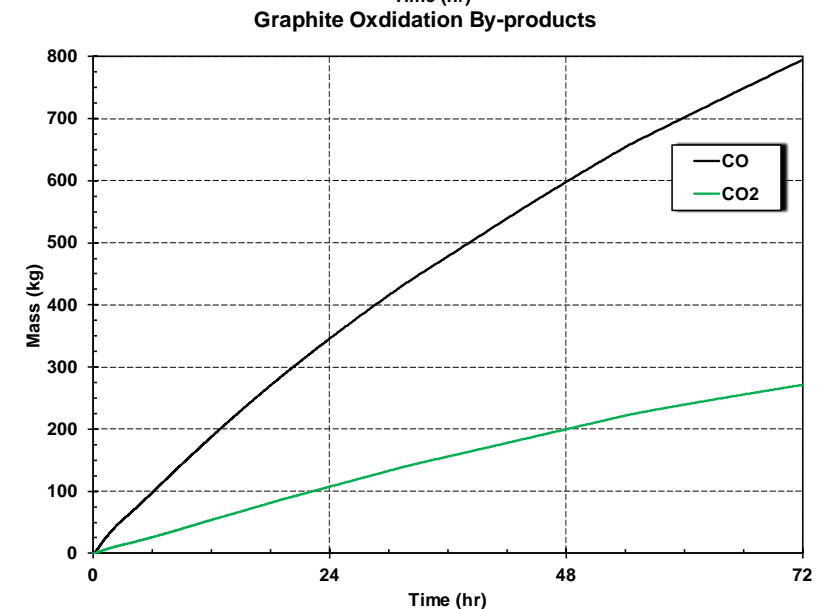
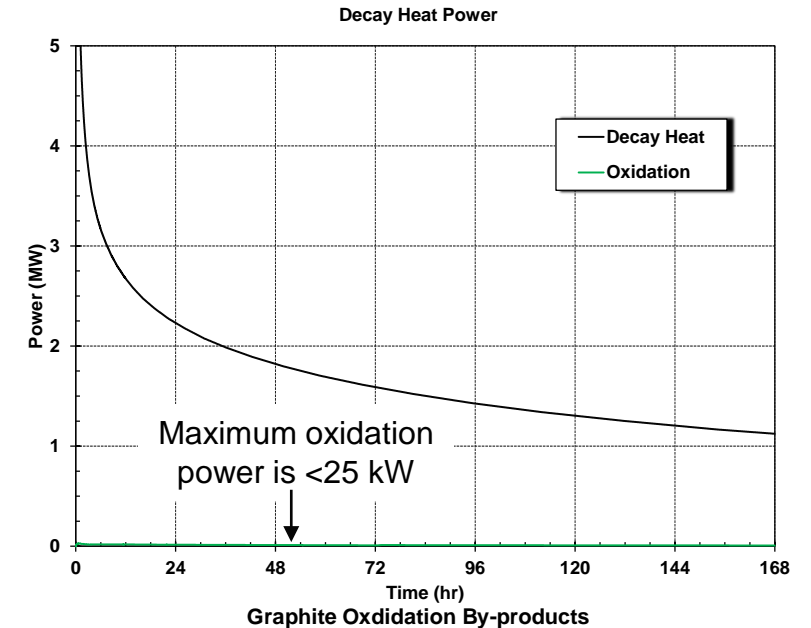

# DLOFC reference case results (4/7)

## Potential for combustion in the reactor building

- MELCOR lower limit for CO combustion with an ignition source is 12.9% (~2X higher than for hydrogen)
- Highly dependent on local concentrations and building design and interconnectivity
- Demo reactor building assumes high inter-connectivity
  - Allows air and CO circulation
- No carbon-dioxide burns were predicted through 168 hr

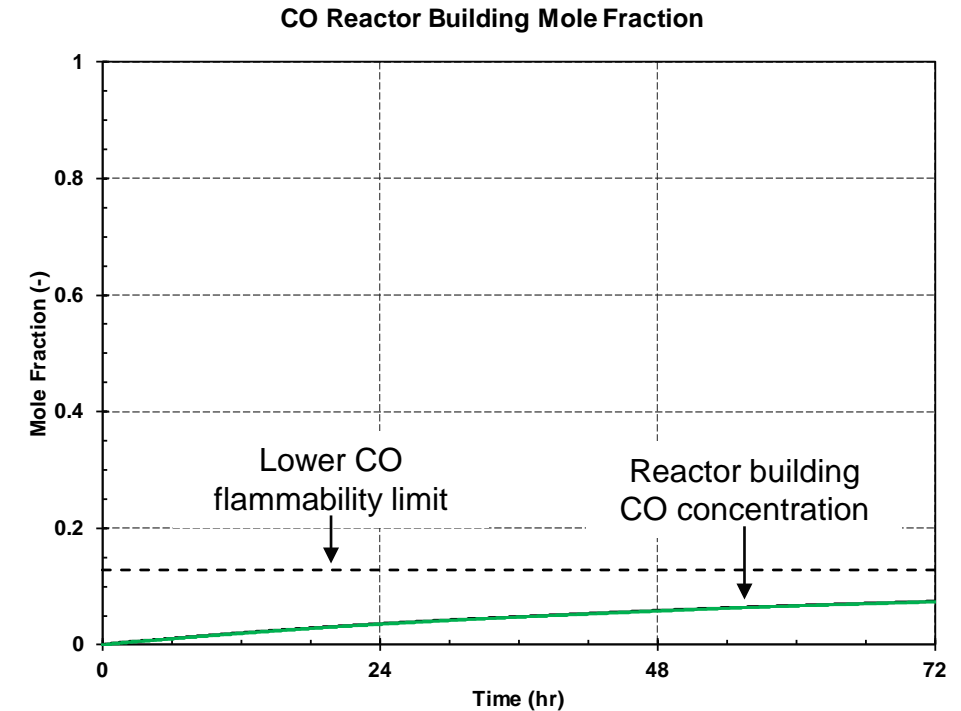

# DLOFC reference case results (5/7)

MELCOR predicts release and transport from fuel to the environment

- Fuel heat-up
- TRISO layers – Initial failure fraction + failures during heat-up
- Pebble matrix and pebble outer shell – Higher diffusivity at elevated temperatures, recoil, and air oxidation
- Primary system – Failed with the initiating event
- Reactor building – Design leakage

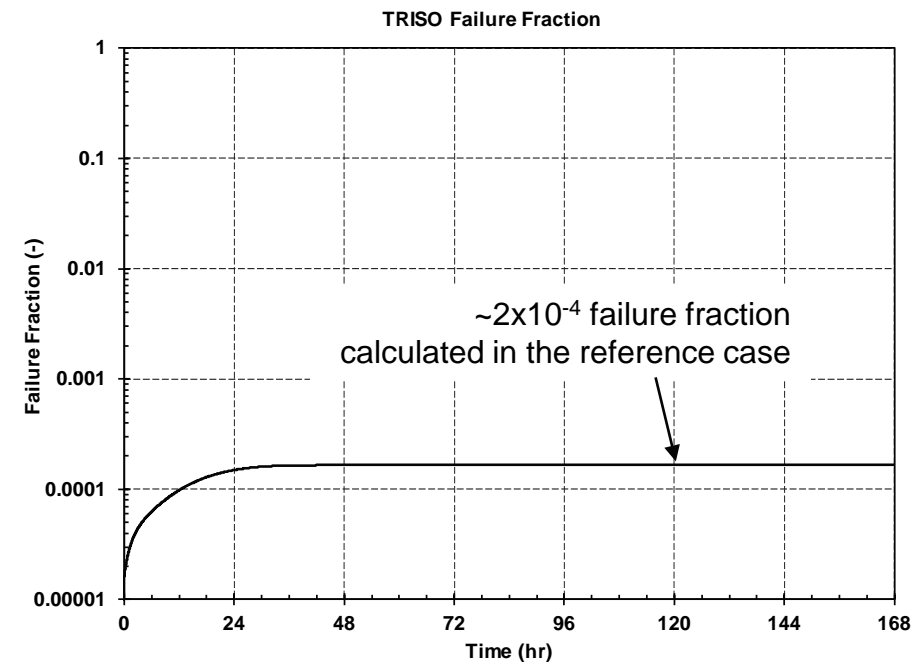
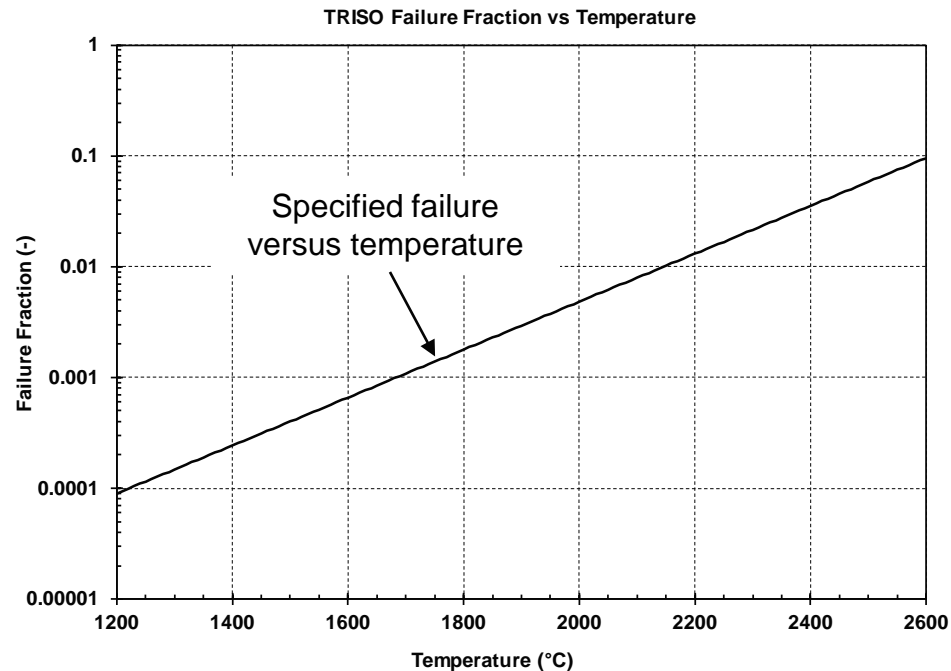

# DLOFC reference case results (6/7)

The impact of the low TRISO failure fraction leads to small releases

- Iodine diffusivity assumed to be same as krypton
- Assumes most iodine reacts with cesium
- Larger cesium release due its the higher diffusivity
- Ag release to the environment is  $1.2 \times 10^{-3}$  (highest diffusivity)

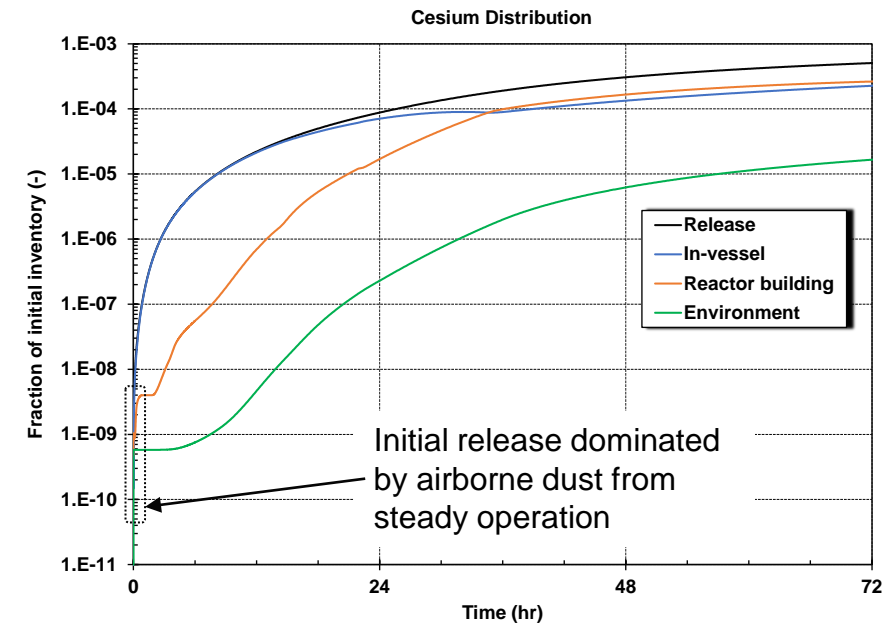
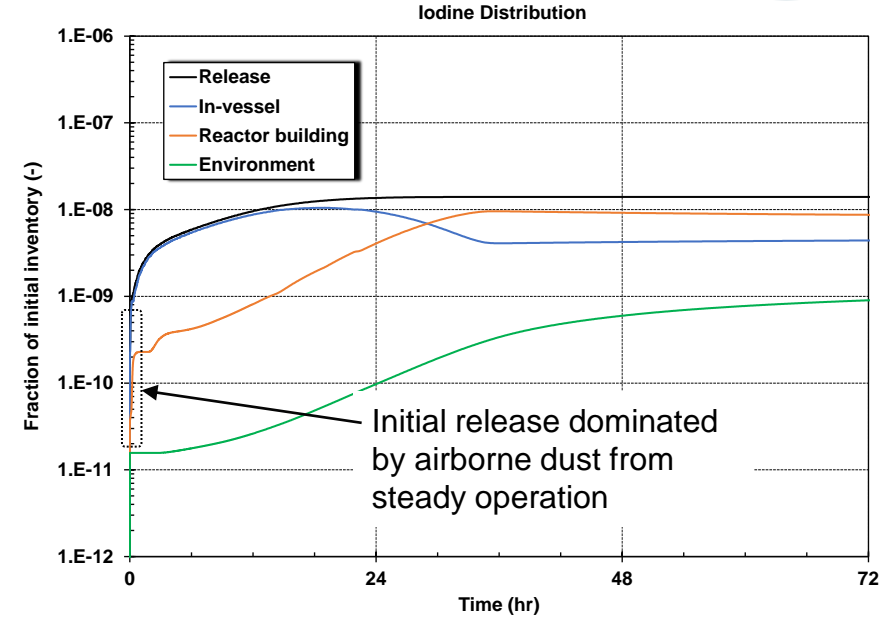

# DLOFC reference case results (7/7)

Of the small release from the fuel...

34% and 62% of iodine and cesium, respectively, retained in the vessel

- Thermally-stratified orientation limits vessel releases
- Low flowrate combined with aerosol deposition
- Inclusion of graphite oxidation reaction products (CO and CO<sub>2</sub>) promotes more flow and therefore more releases from the vessel

58% and 34% of iodine and cesium, respectively, retained in the reactor building

- No strong driving force for reactor building leakage
  - Reference model uses a hole size equivalent to 100% leakage per day at a design pressure of 0.25 psig (3.2 in<sup>2</sup>)

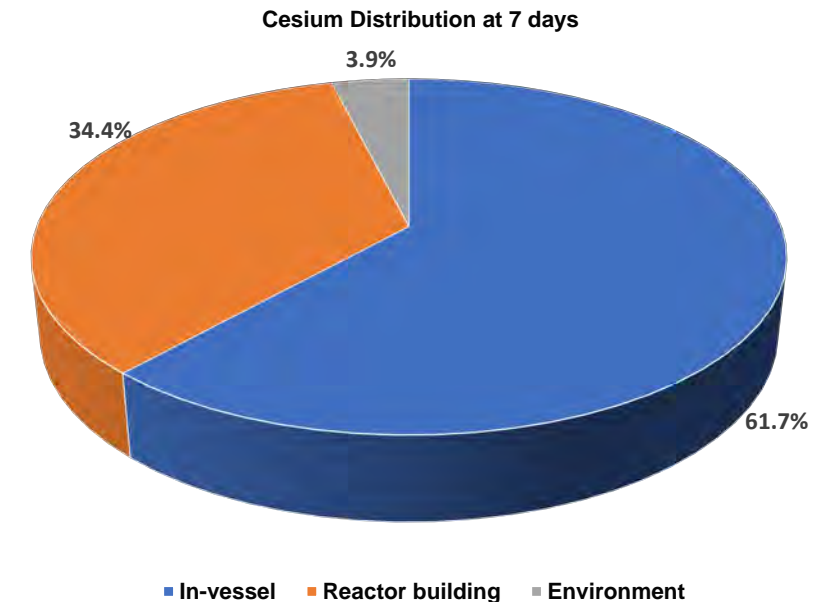
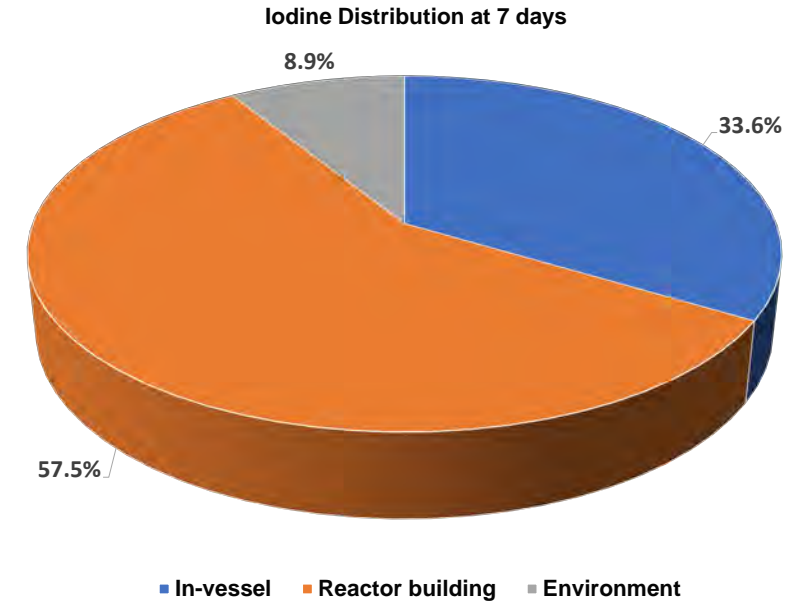

# MELCOR can be used to explore the variability of the results to uncertainties

Model	Parameter	Distribution	Range
<b>TRISO Model Parameters</b>	Initial TRISO Failure Fraction (fraction of inventory)	Log uniform	$10^{-5} - 10^{-3}$
	TRISO Failure Rate Multiplier (-)	Log uniform	0.1 – 10.0
	Intact TRISO Diffusivity Multiplier (-)	Log uniform	0.001 – 1000.0
	Failed TRISO Diffusivity Multiplier (-)	Log uniform	0.001 – 1000.0
	Matrix Diffusivity Multiplier (-)	Log uniform	0.001 – 1000.0
	TRISO Pebble Emissivity (-)	Uniform	0.5 – 0.999
	TRISO Pebble Bed Porosity (-)	Uniform	0.3 – 0.5
	TRISO recoil fraction (-)	Uniform	0 – 0.03
<b>Radionuclide Model Parameters</b>	Shape Factor (-)	Uniform	1.0 – 5.0
	Gaseous Iodine Multiplier (Base = 5% I <sub>2</sub> )	Uniform	0.02 – 1.0
<b>Design Parameters</b>	Graphite Conductivity Multiplier (-)	Uniform	0.5 – 1.5
	Decay Heat Multiplier (-)	Uniform	0.9 – 1.1
	RCCS Blockage Multiplier (-)	Log uniform	0.001 – 1.0
	RCCS Emissivity (-)	Uniform	0.1 – 1.0
	Reactor Building Leakage Multiplier (-)	Log uniform	0.1 – 100.0
	Wind speed (m/s)	Uniform	0 - 10



# Single parameter sensitivity results (1/4)

The sensitivity parameters were sampled at the minimum and maximum values to illustrate their impacts

- A low graphite conductivity has the largest impact on the peak fuel temperature
  - Graphite conductivity varies considerably with irradiation (>10X) and also varies with temperature
- $\pm 10\%$  decay heat has next largest impact on the peak fuel temperature
- High/low emissivity, the next most important single factor, is used as a surrogate for the relative importance of radiative exchange in the pebble bed
- Debris bed porosity had a small effect on the peak fuel temperature
- Heat dissipation limits the magnitude of the initial peak for a blocked RCCS
  - Slow heat-up to 1800°C by 7 days

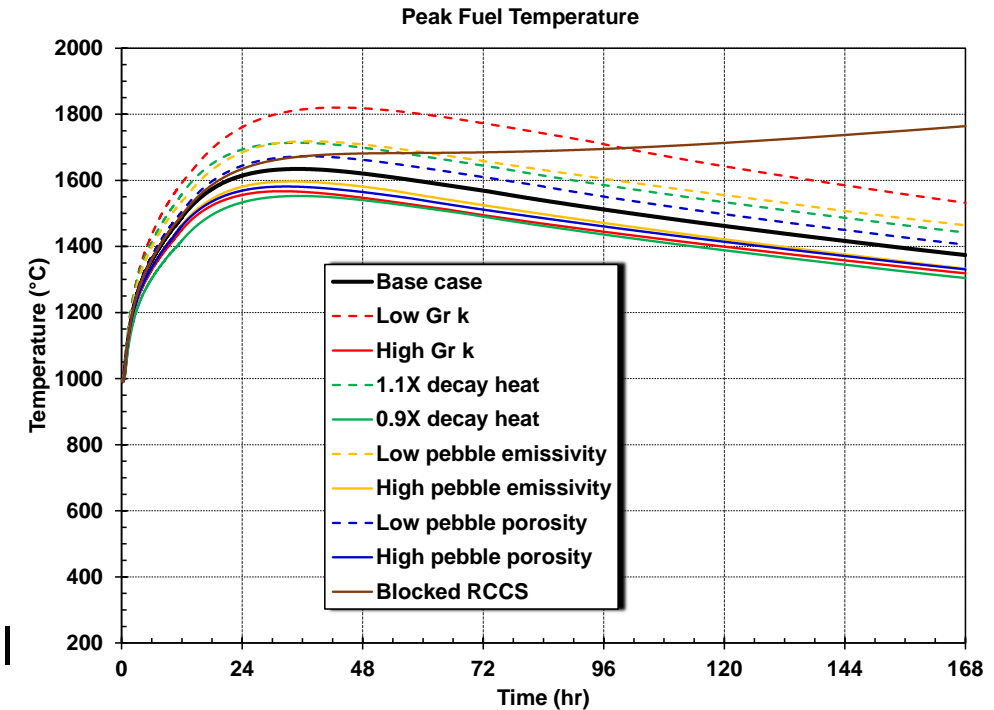

# Examples of single parameter sensitivity results (2/4)

As the peak fuel temperature rises, the TRISO failure fraction increases

- Blocked RCCS does not have impact for several days

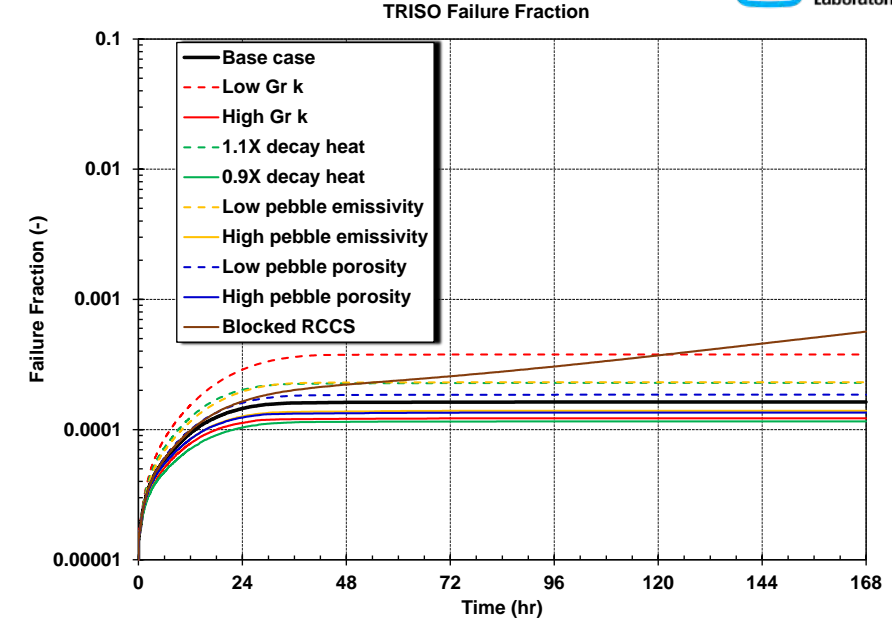

The cesium environmental release shows an order of magnitude variation

- Reflects variations in release from the pebbles
- Graphite conductivity had the largest impact
- Variations in emissivity = uncertainty in radiative heat transport (similar to  $\pm 10\%$  in decay heat power)
- Pebble porosity had a small impact

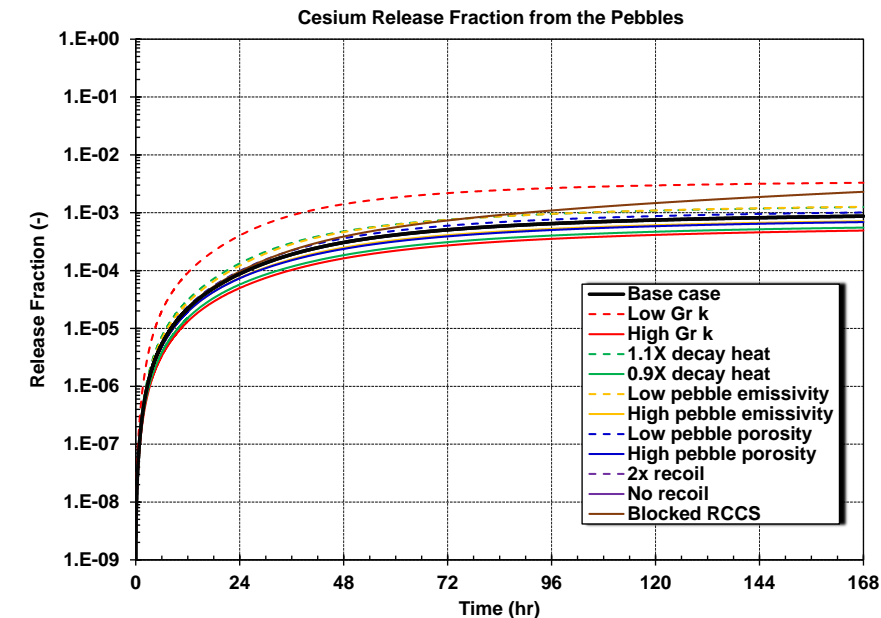

# Examples of single parameter sensitivity results (3/4)

Larger hole size in the building and higher wind speed causes higher releases to environment

- 100X building leakage has less than a 10X impact
- External wind has small effect

Graphite oxidation and the associated CO/CO<sub>2</sub> production did not increase the source term

- CO/CO<sub>2</sub> gas production did not increase environment release

Early impacts of the recoil and initial TRISO failure fraction did not impact long-term environmental release

- Magnitude of the release dominated by the fuel temperature response and the TRISO failure model

Late step change in the blocked RCCS release is due to a carbon monoxide burn

- Building pressurization forces out airborne radionuclides

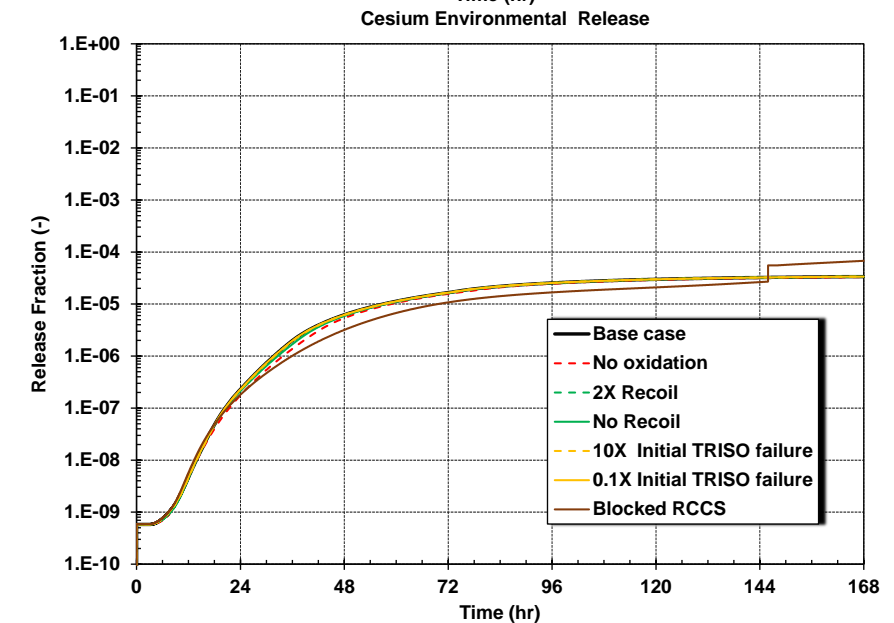
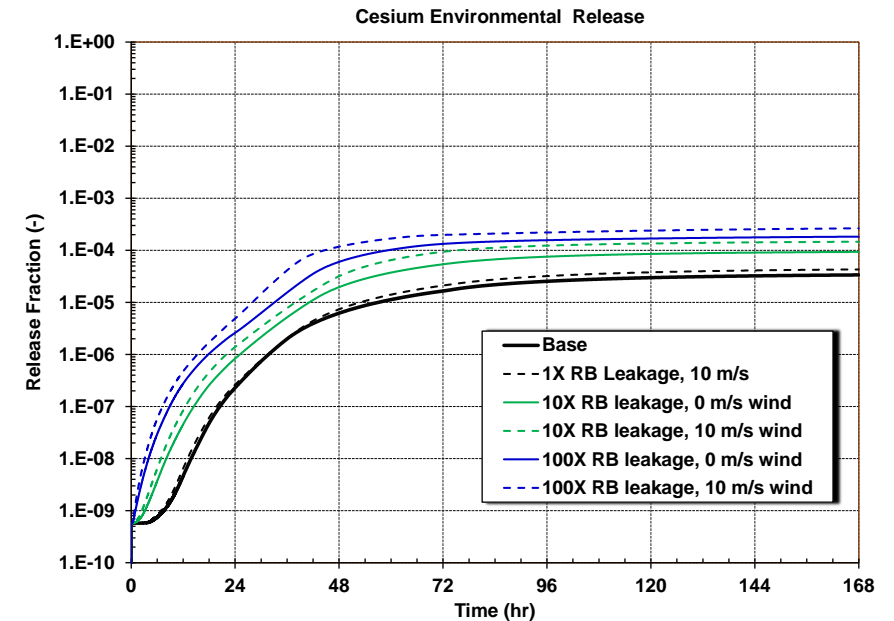

# Examples of single parameter sensitivity results (4/4)

## Blocked RCCS leads to higher CO generation

- Ratio of reaction products is dependent on the temperature of the graphite
- Blocked RCCS generates ~9% more moles of CO and CO<sub>2</sub>

## Higher CO generation led to a burn in the steam generator compartment (pipe break location)

- Incomplete burn with slow flame speed
  - Low oxygen concentration (6.8%)
- 0.25 bar (3.5 psi) pressure rise
- Burn creates non-condensable CO<sub>2</sub>
  - No subsequent condensation

Graphite Oxidation By-products

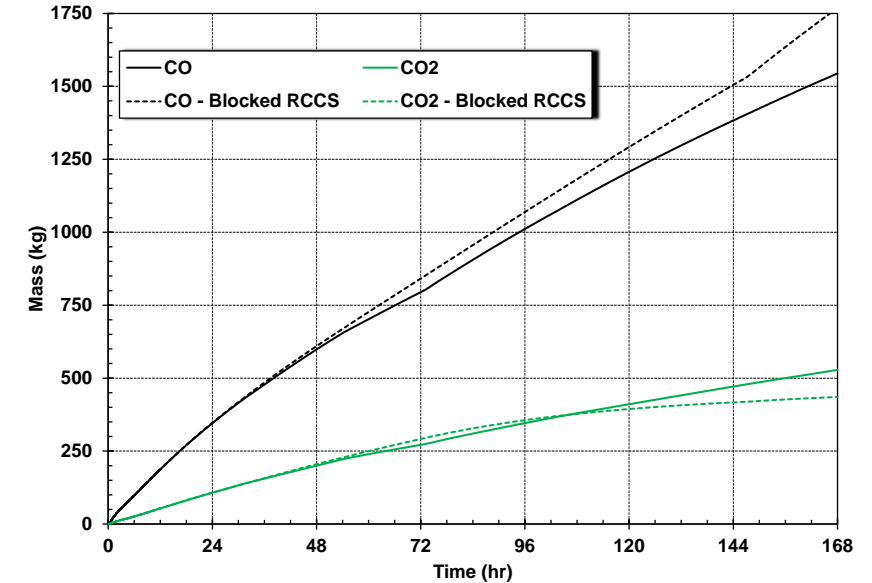

Reactor Building CO Mole Fraction

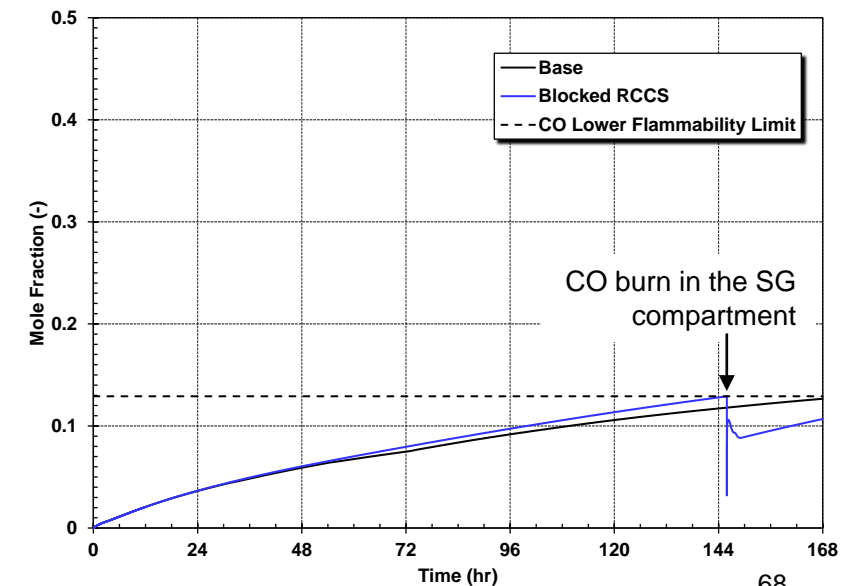

# High-Temperature Gas-Cooled Reactor Uncertainty Analysis



**U.S. NRC**



# Role of MELCOR in Resolving Uncertainty

## Uncertainty

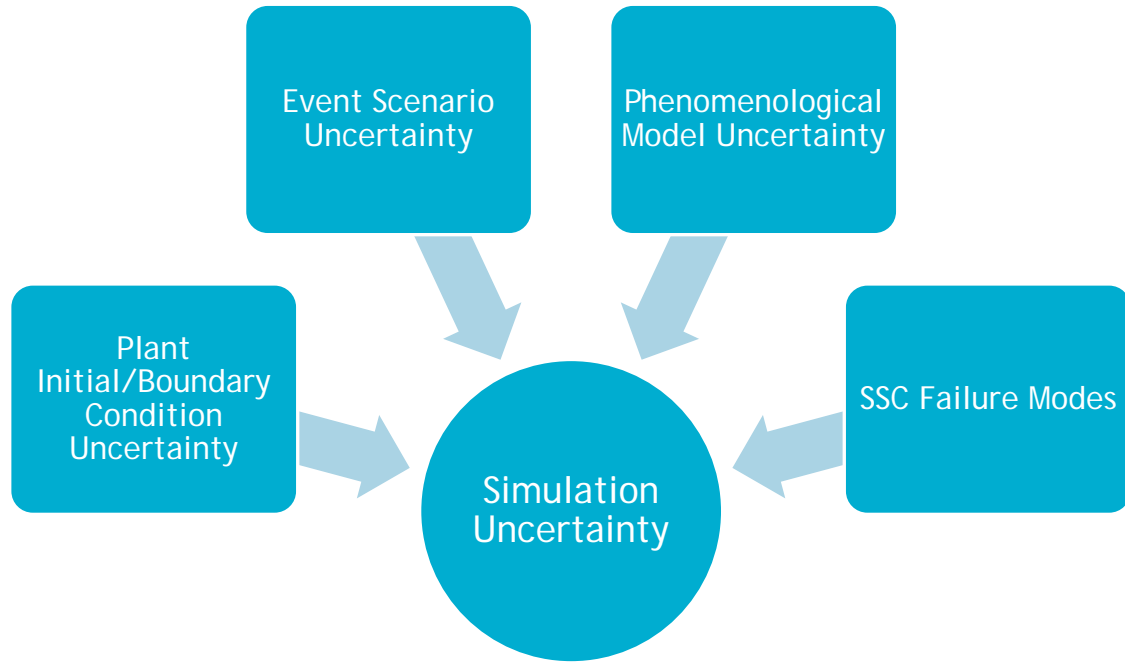

## Engineering Performance

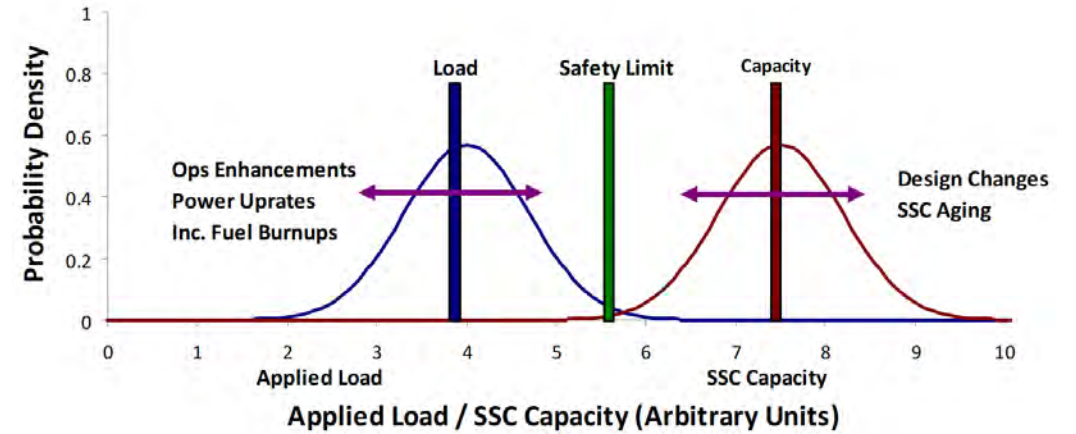

## Risk-Informed Assessment

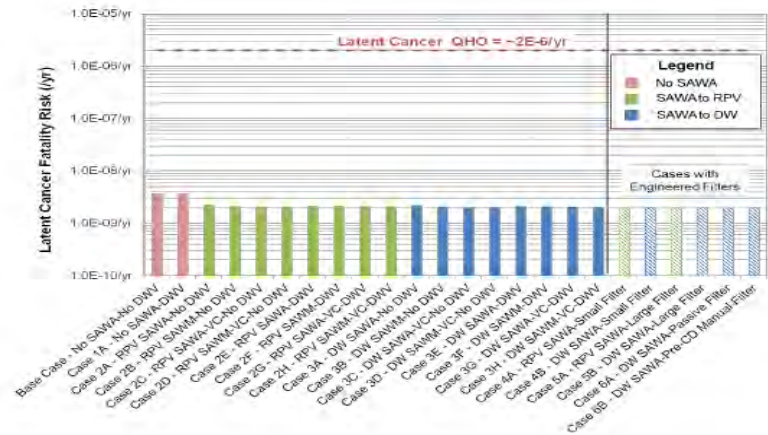

# Evolution from MELCOR LWR Uncertainty Analysis

## Overall motivation

- A clustering of system responses provides insights on important assumptions and modeling parameters
- Provides a most likely release and range of releases for the scenario

## MELCOR application to LWRs

- Range of SOARCA uncertainty studies
- PWR and BWR plant uncertainty studies
- Resolved role of uncertainty in critical severe accident issues

## Commonalities between LWR and HTGR

- Chemical form of key elements
- Aerosol physics parameters (e.g., shape factor)
- Operating time before accident happens
- Containment leakage hole size

## Parameter selection emphasized potential HTGR-specific uncertainties

- Ran 2000 realizations on High Performance Computer

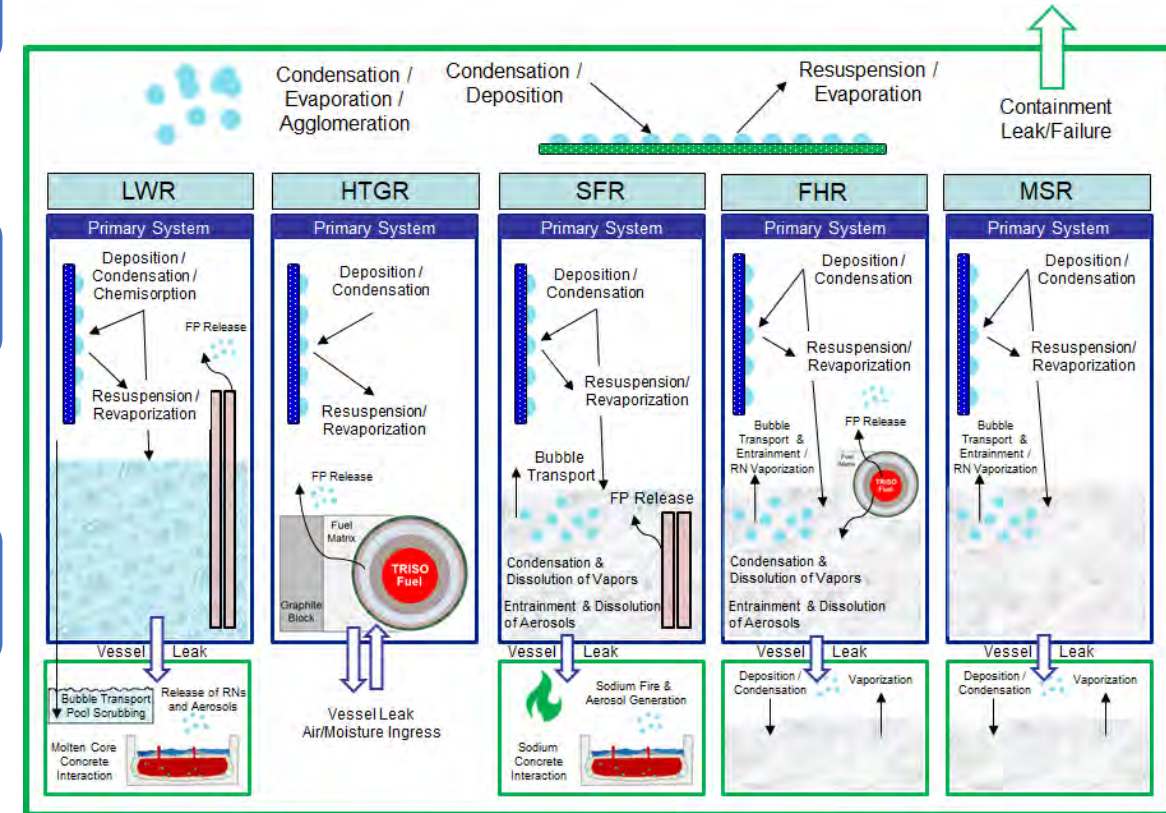

# Parametric Uncertainty – Capability Demonstration

Model	Parameter	Distribution	Range
<b>TRISO Model Parameters</b>	Initial TRISO Failure Fraction (fraction of inventory)	Log uniform	$10^{-5} - 10^{-3}$
	TRISO Failure Rate Multiplier (-)	Log uniform	0.1 – 100.0
	Intact TRISO Diffusivity Multiplier (-)	Log uniform	0.001 – 1000.0
	Failed TRISO Diffusivity Multiplier (-)	Log uniform	0.001 – 1000.0
	Matrix Diffusivity Multiplier (-)	Log uniform	0.001 – 1000.0
	TRISO Pebble Emissivity (-)	Uniform	0.5 – 0.999
	TRISO Pebble Bed Porosity (-)	Uniform	0.3 – 0.5
	TRISO recoil fraction (-)	Uniform	0 – 0.03
<b>Radionuclide Model Parameters</b>	Shape Factor (-)	Uniform	1.0 – 5.0
	Gaseous Iodine Multiplier (Base = 5% I <sub>2</sub> )	Uniform	0.02 – 1.0
<b>Design Parameters</b>	Graphite Conductivity Multiplier (-)	Uniform	0.5 – 1.5
	Decay Heat Multiplier (-)	Uniform	0.9 – 1.1
	RCCS Blockage Multiplier (-)	Log uniform	0.001 – 1.0
	RCCS Emissivity (-)	Uniform	0.1 – 1.0
	Reactor Building Leakage Multiplier (-)	Log uniform	0.1 – 100.0
	Wind speed (m/s)	Uniform	0 - 10



# UO<sub>2</sub> Thermal Response

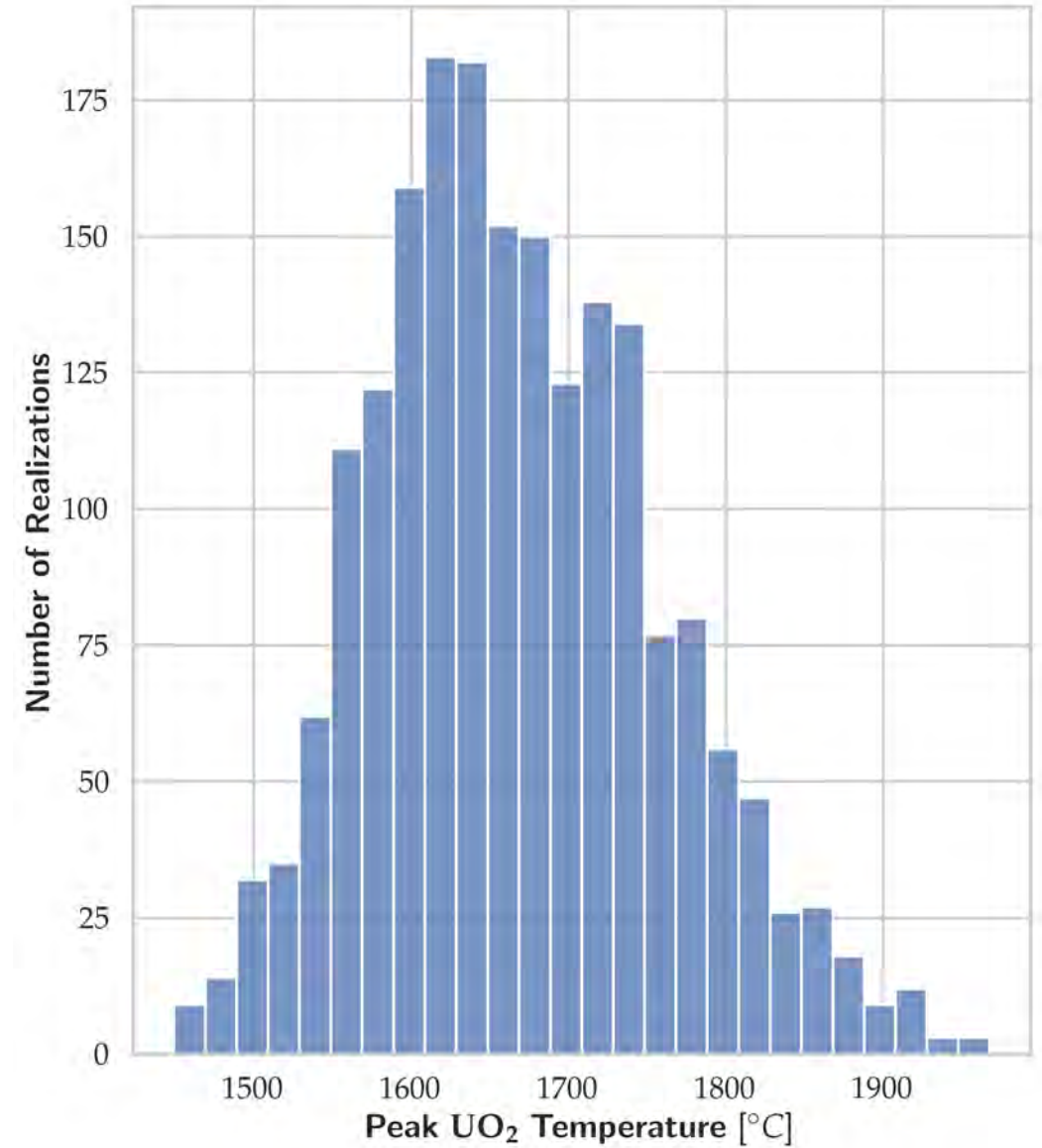
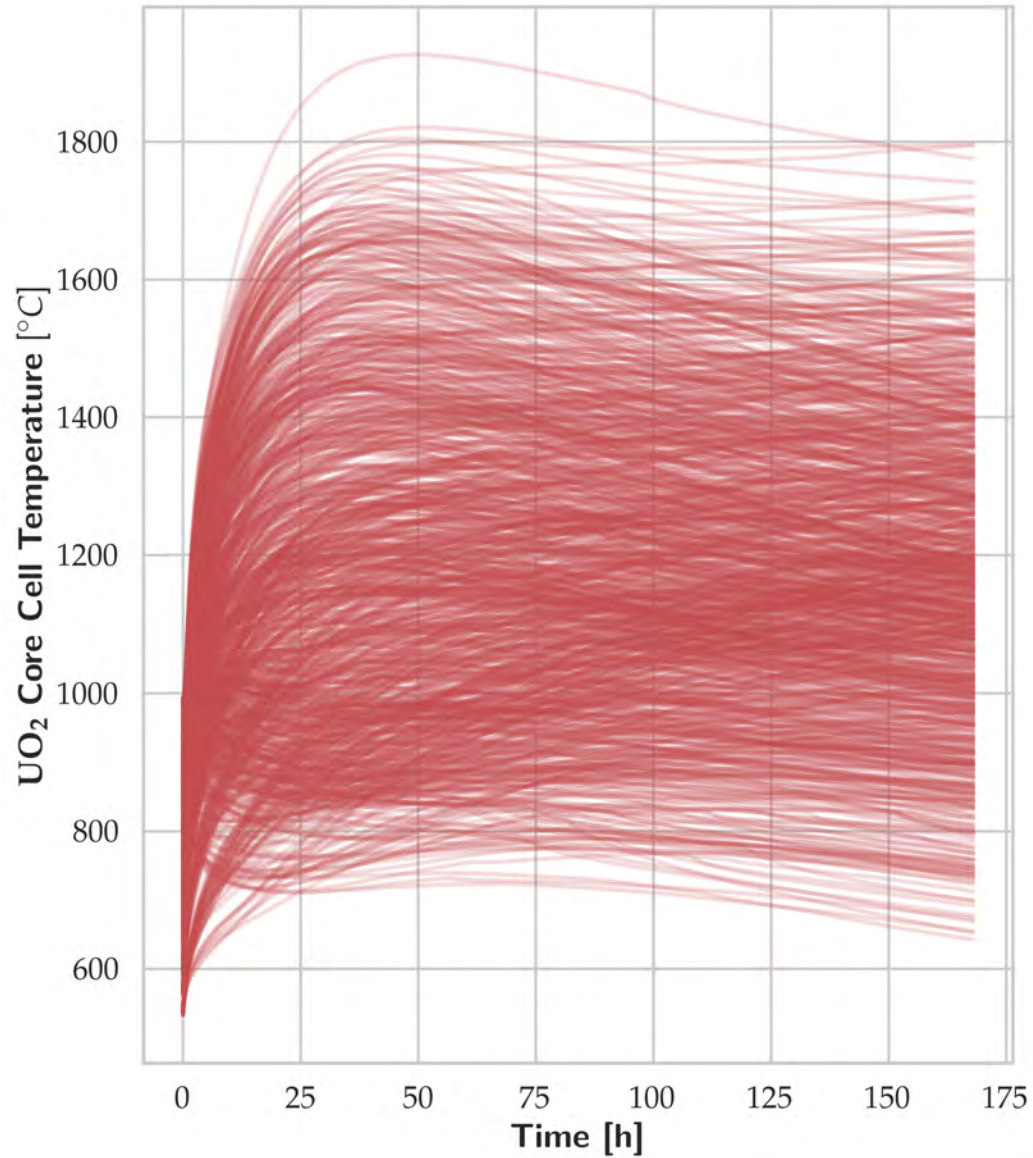

# UO<sub>2</sub> Thermal Transient Evolution

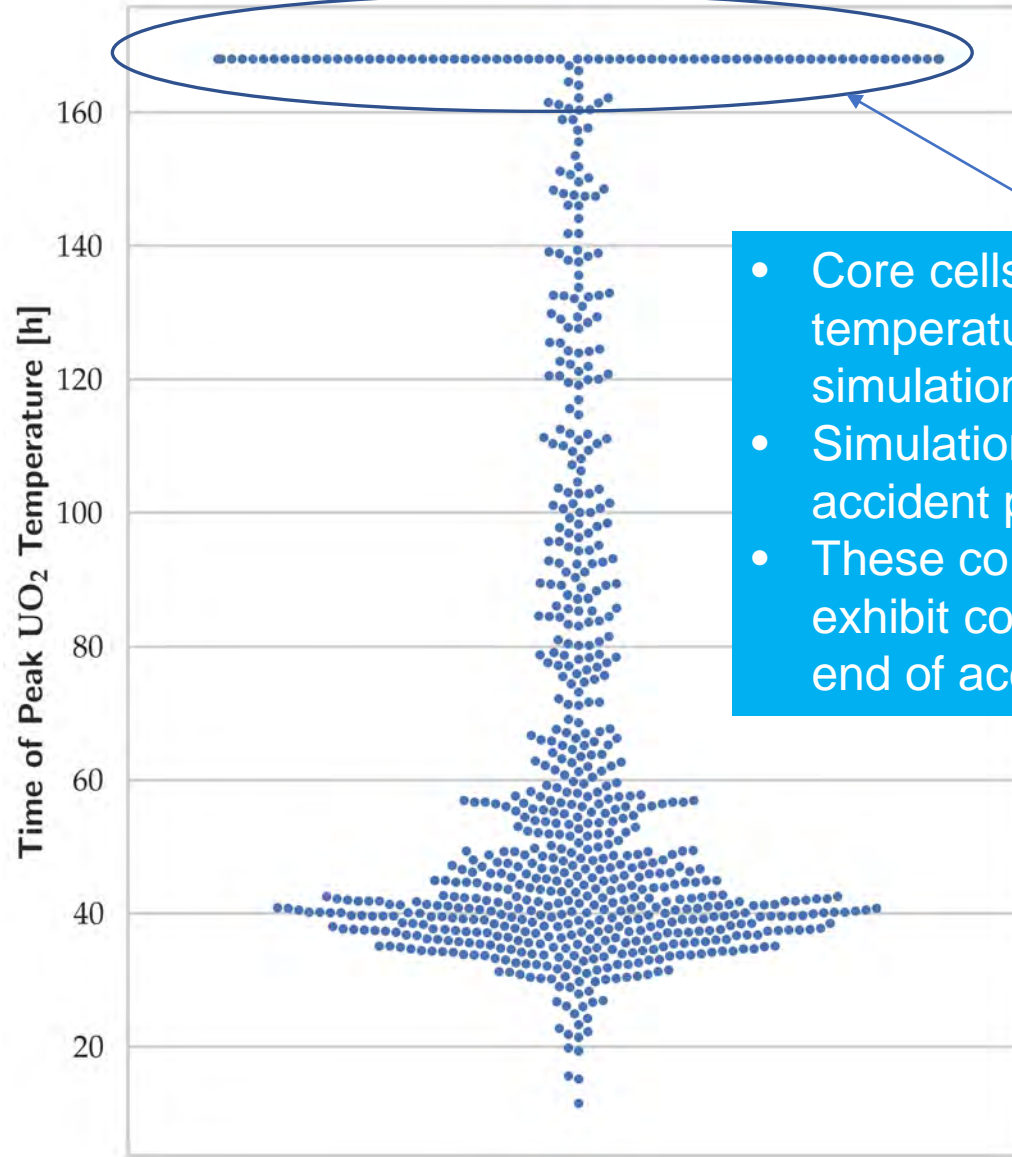
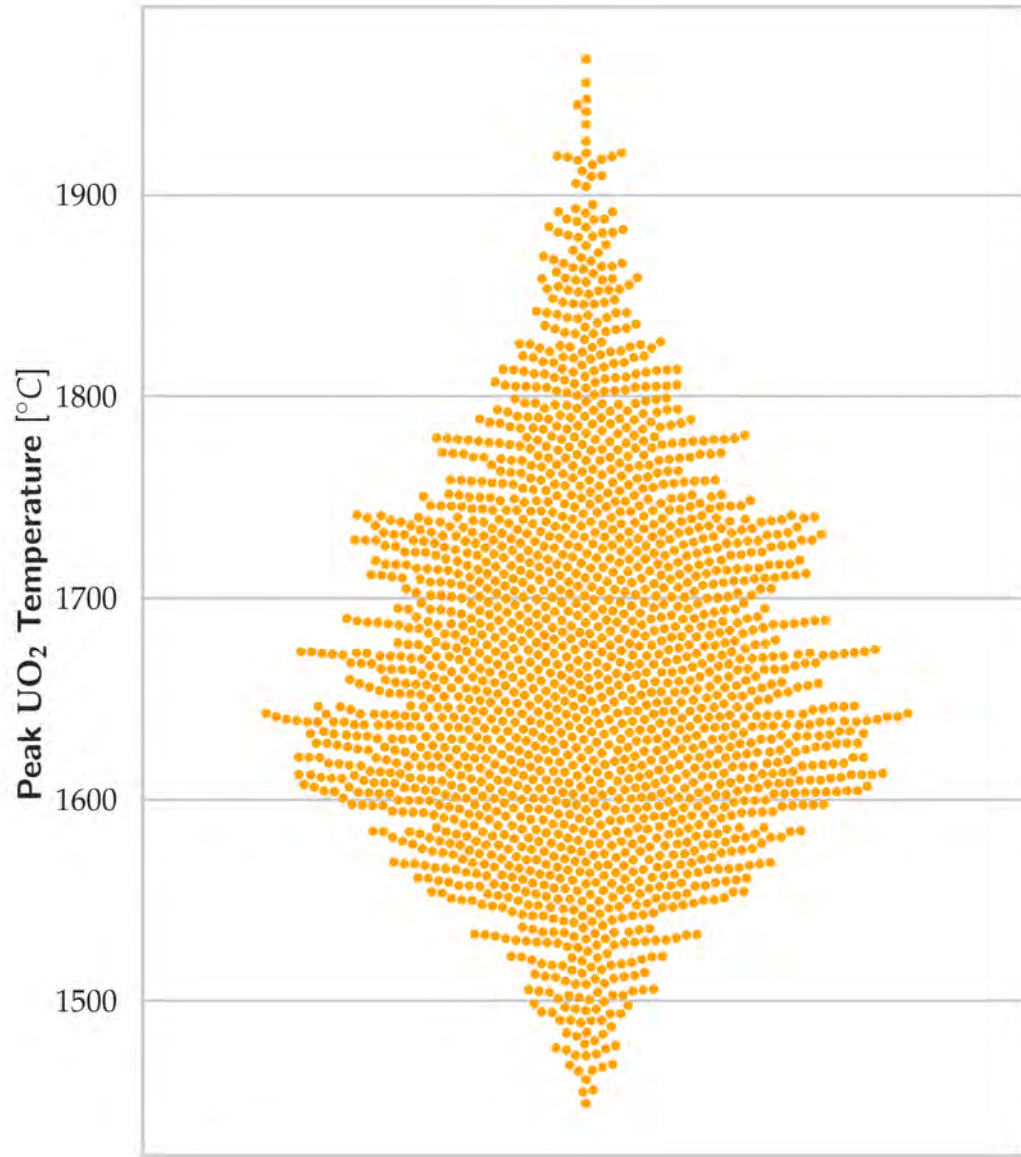

- Core cells with peak fuel temperatures at end of simulation
- Simulation time denoted as accident phase
- These core cells do not exhibit cooldown prior to end of accident phase

# TRISO Particle Failure

Long-term TRISO particle failure possible for core cells exhibiting prolonged over-temperatures

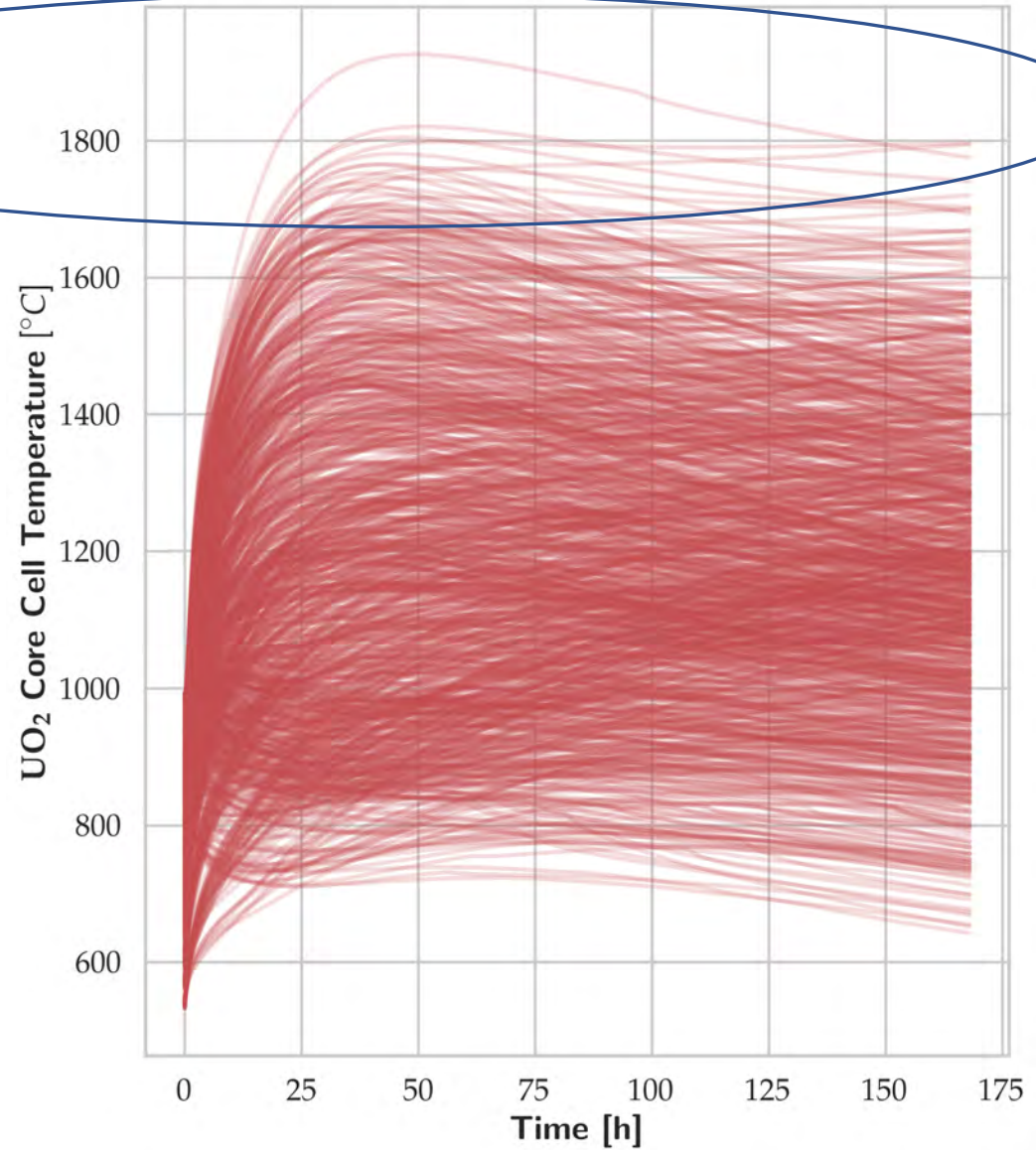
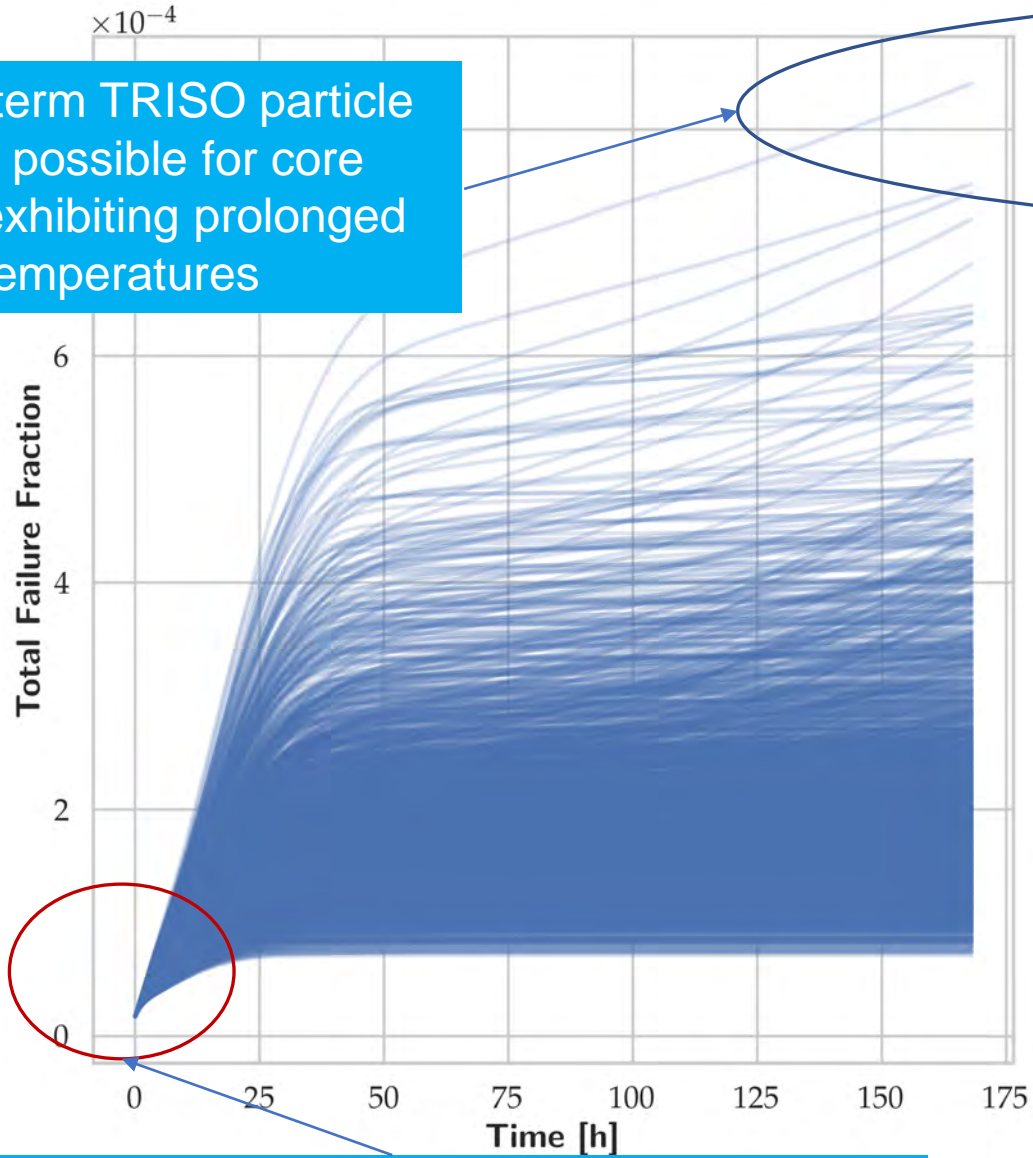

Initial distribution of failed TRISO particles

# Evolution of TRISO Particle Failures

Long-term failures of TRISO particles at lower rate but driven by prolonged period of elevated fuel temperature

Rapid growth in failure fraction driven by the early temperature excursion

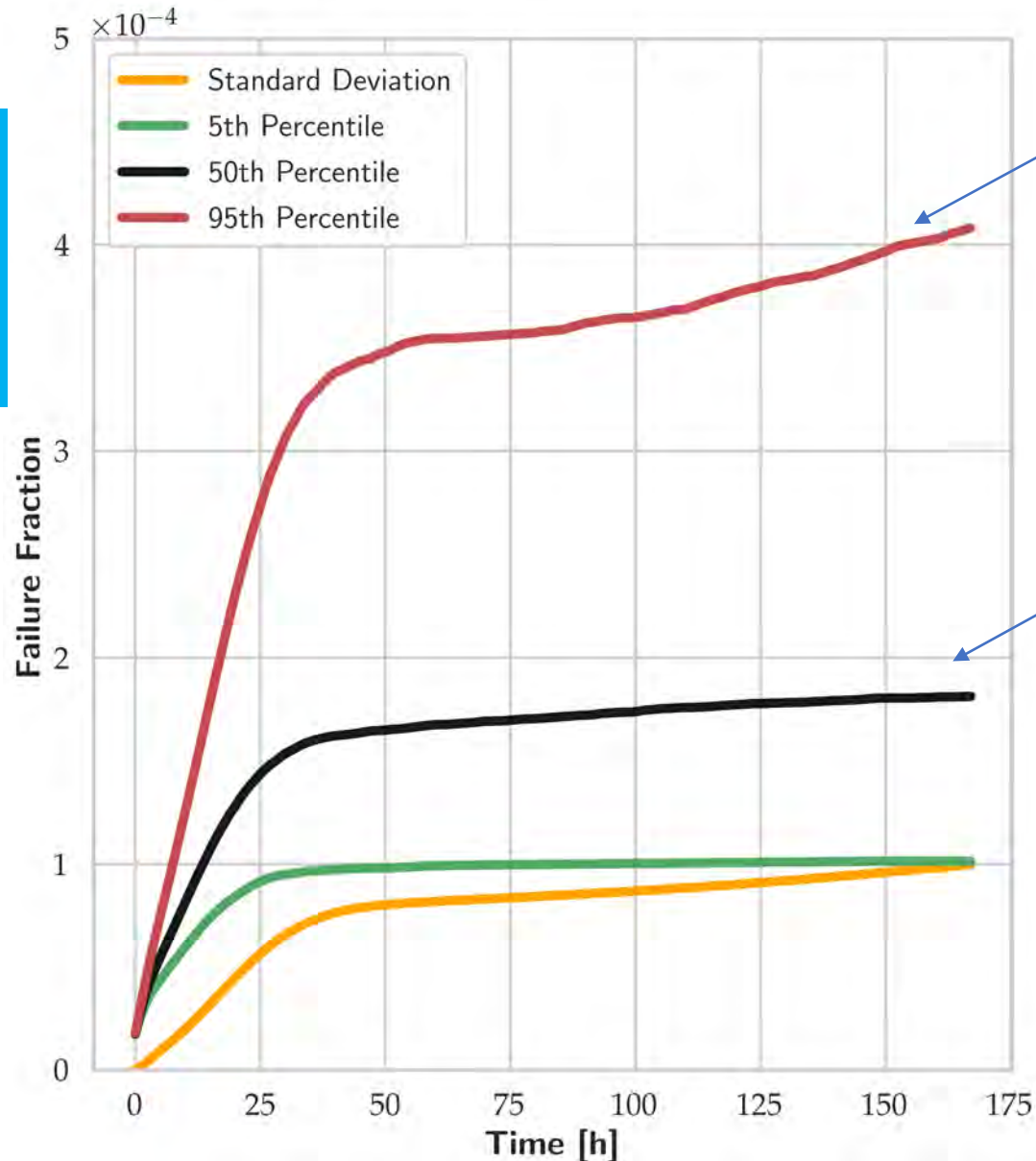

Tails of realizations contributing to longer term growth of TRISO particle failures

50<sup>th</sup> percentile reasonably stable in the long-term

Lower rates of failure entirely driven by early temperature excursion  
 Variability in peak fuel temperature and cooldown transient dominates higher failure rate realizations

# Role of Decay Heat Rejection – Latest Time to Peak Fuel Temperature

Latest Time to Peak  $UO_2$  Temperature [h]

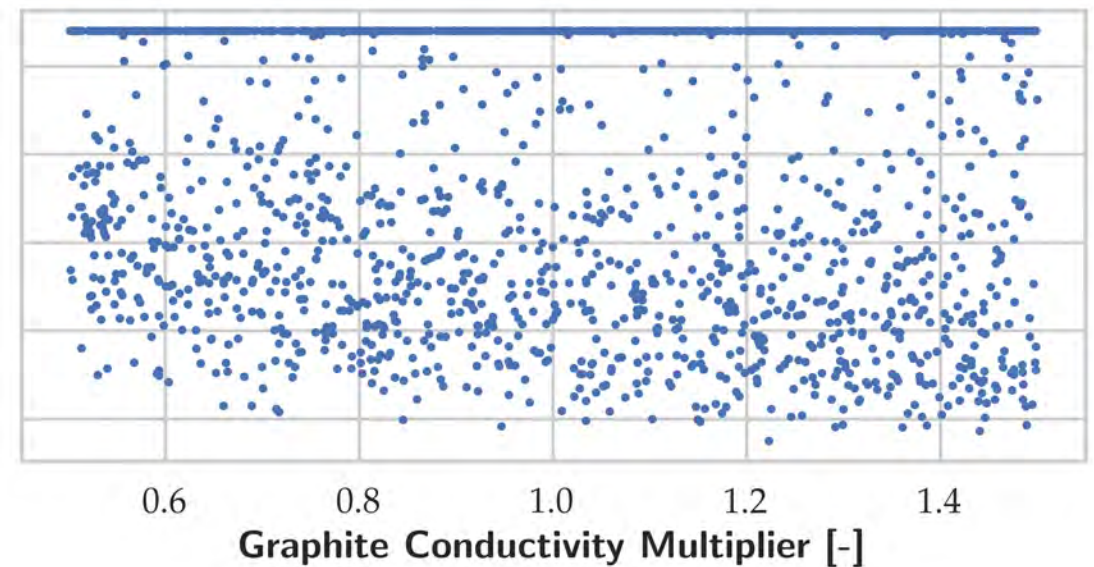
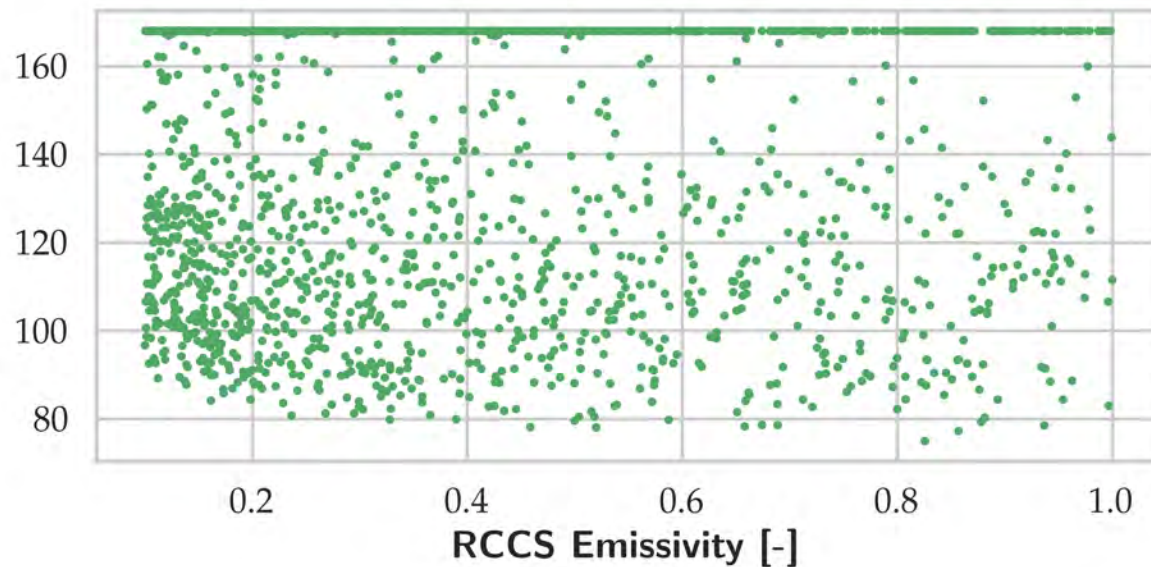
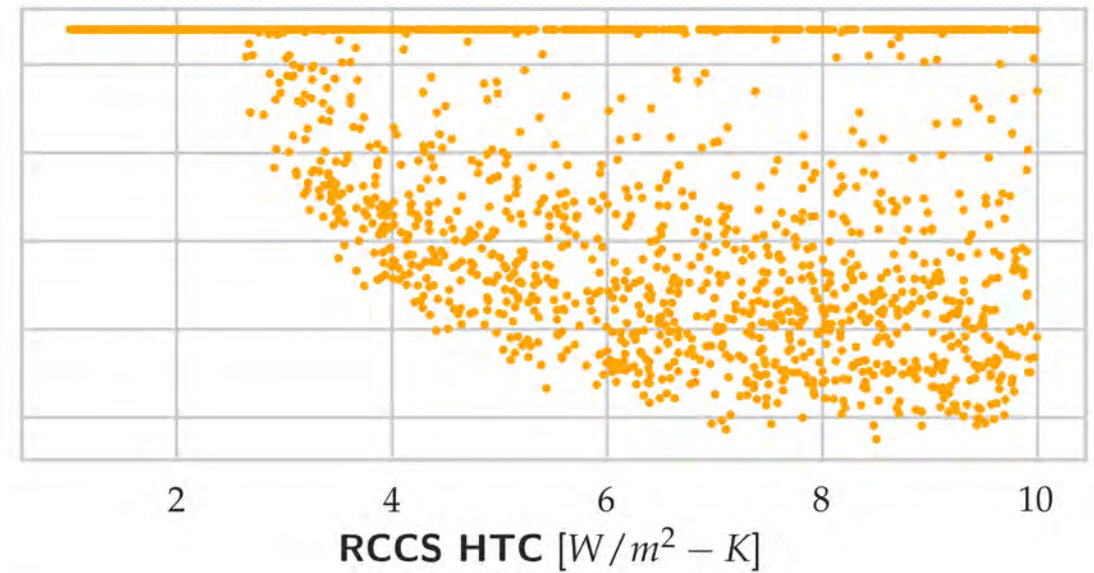
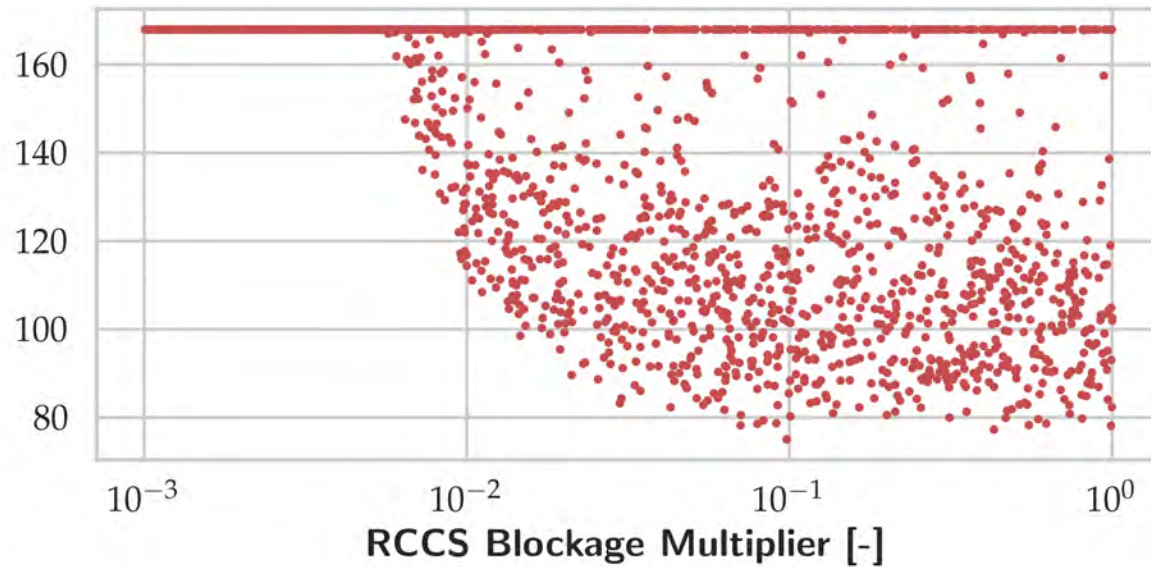

# Role of Decay Heat Rejection – Peak Fuel Temperature

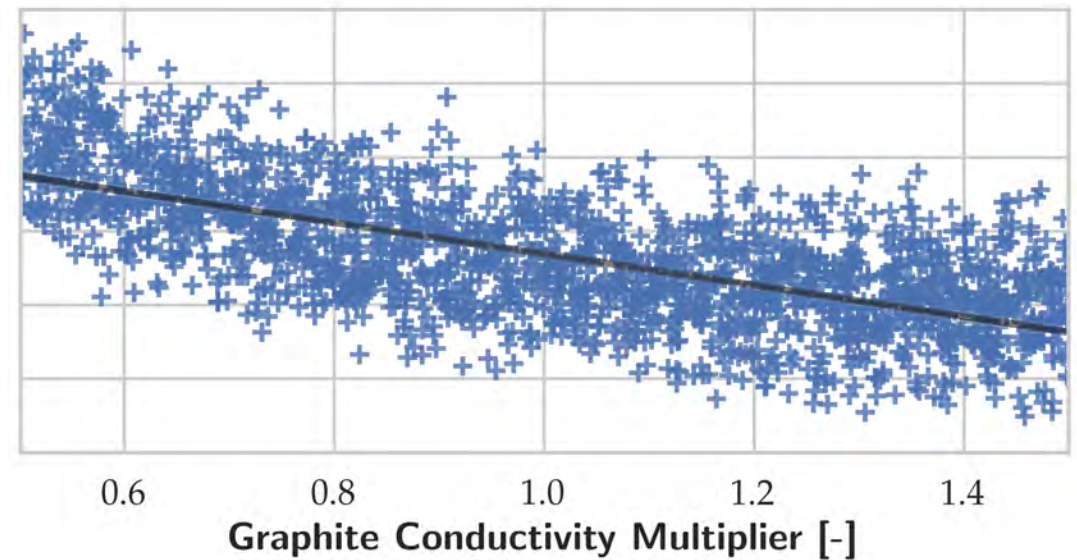
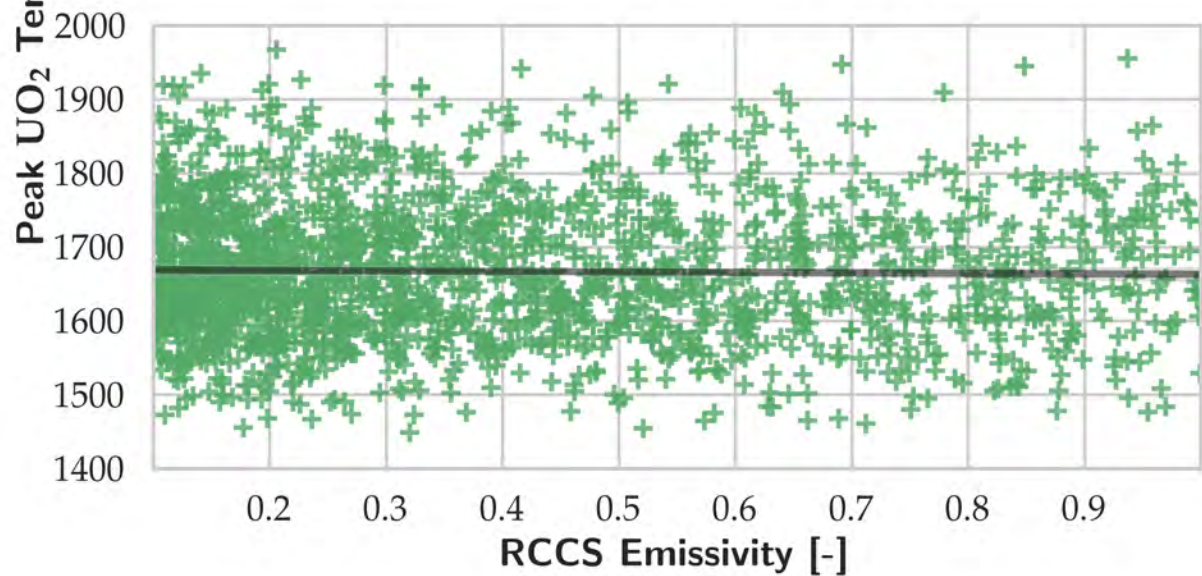
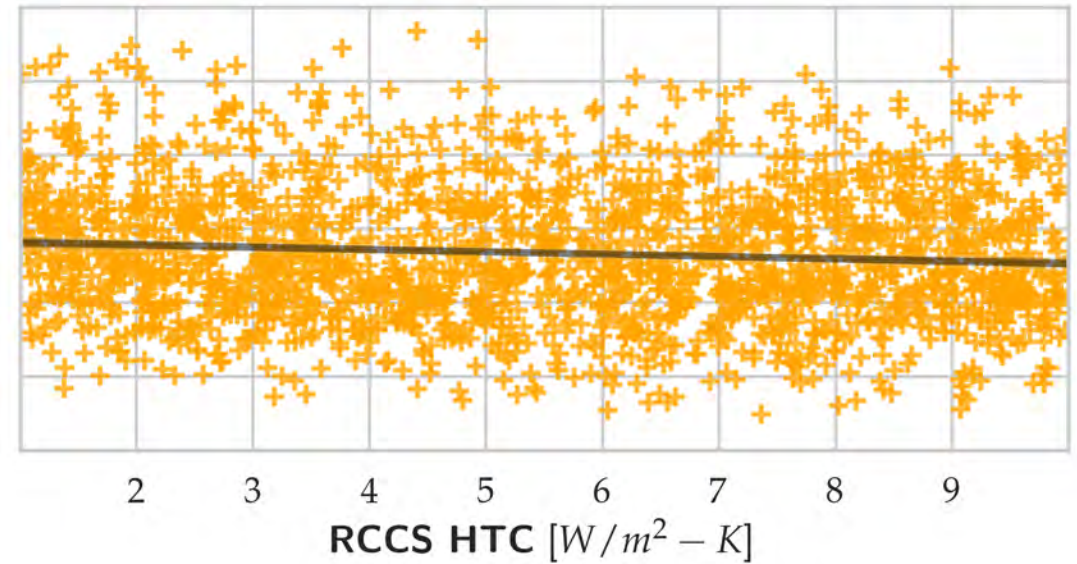
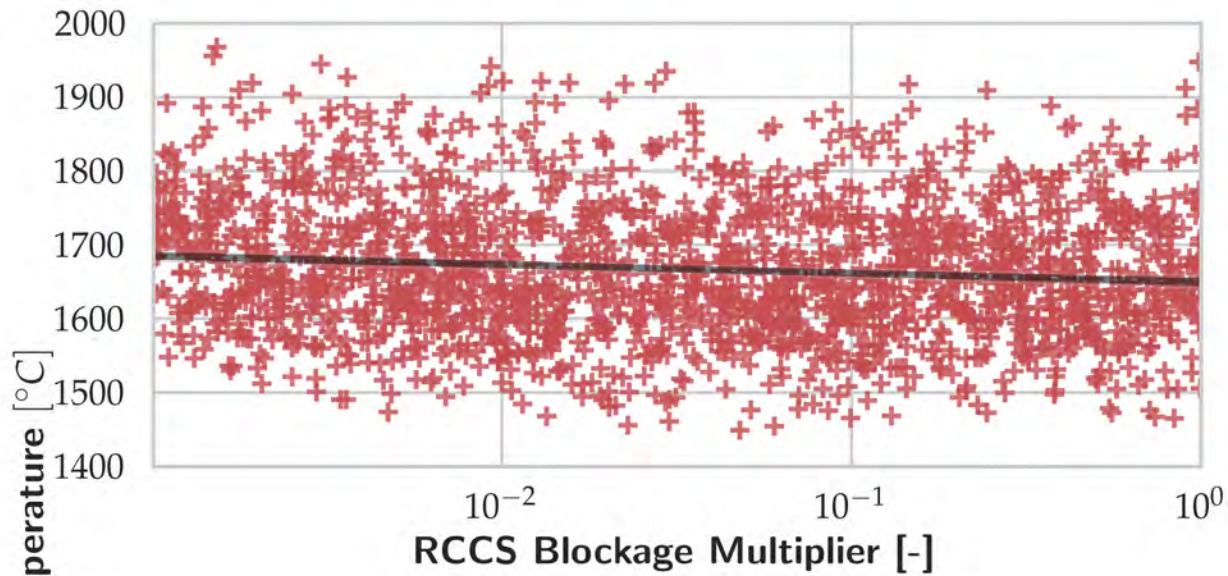

# Summary



**U.S. NRC**



**Sandia  
National  
Laboratories**

# Conclusions

Added HTGR modeling capabilities to SCALE & MELCOR for HTGR source term analysis to show code readiness

Modeling demonstrated for a DLOFC Scenario

- Input of detailed ORIGEN radionuclide inventory data from ORNL
- Input radial and axial power distributions from ORNL neutronic analysis
- Develop MELCOR input model for exploratory analysis
- Fast-running calculations facilitate sensitivity evaluations

Developed an understanding of non-LWR beyond-design-basis-accident behavior and overall plant response



# SCALE Overview



**U.S. NRC**



# SCALE Development for Regulatory Applications

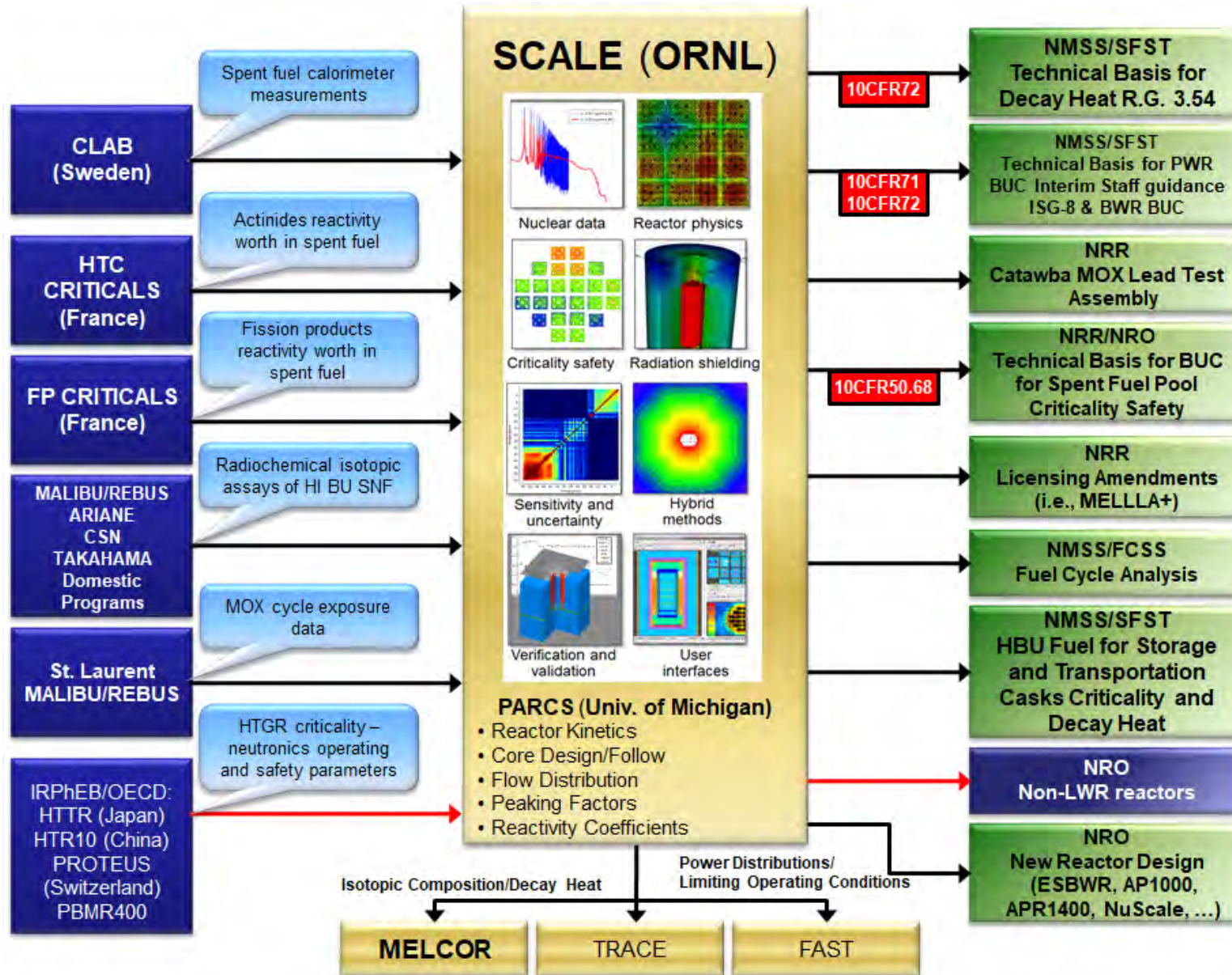

## What Is It?

The SCALE code system is a modeling and simulation suite for nuclear safety analysis and design. It is a modernized code with a long history of application in the regulatory process.

## How Is It Used?

SCALE is used to support licensing activities in NRR (e.g., analysis of spent fuel pool criticality, generating nuclear physics and decay heat parameters for design basis accident analysis) and NMSS (e.g., review of consolidated interim storage facilities, burnup credit).

## Who Uses It?

SCALE is used by the U.S. Nuclear Regulatory Commission (NRC) and in 61 countries (about 10,000 users and 33 regulatory bodies).

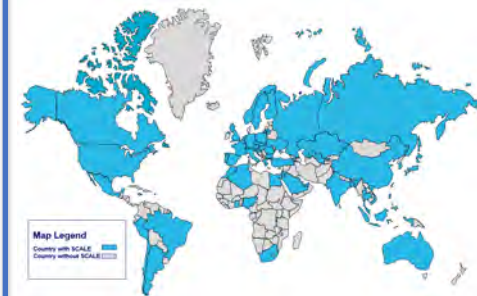

## How Has It Been Assessed?

SCALE has been validated against criticality benchmarks (>1000), destructive assay of fuel and decay heat for PWRs and BWRs (>200)

# Data to generate for MELCOR: QOIs

Code strategy for source term

“NRC Non-Light Water Reactor Vision and Strategy, Volume 3 – Computer Code Development Plans for Severe Accident Progression, Source Term, and Consequence Analysis,” Revision 1, January 2020, ML20030A178

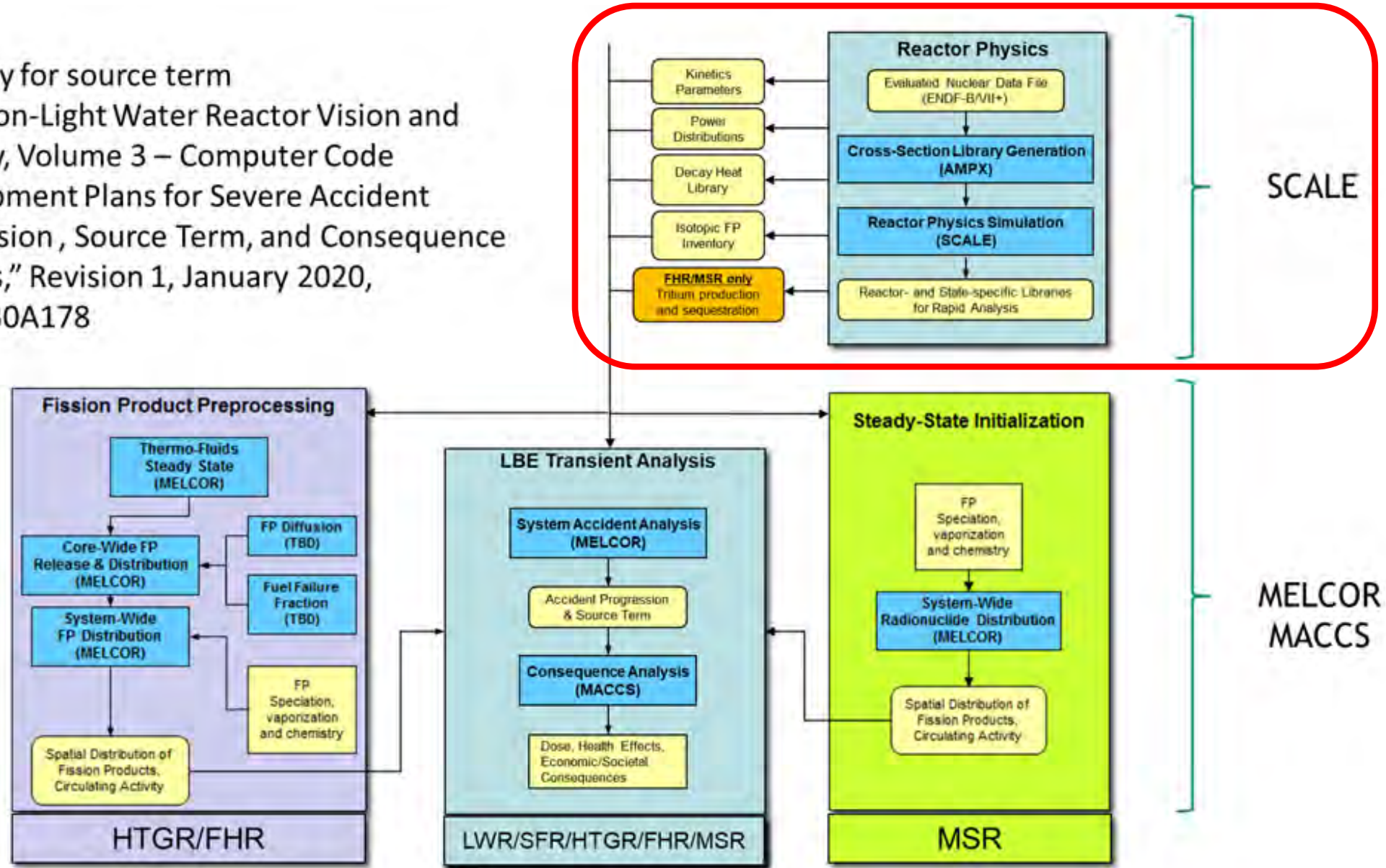

# VSOP Backup Slides



**U.S. NRC**

 **OAK RIDGE**  
National Laboratory

 **Sandia**  
National  
Laboratories

# VSOP workflow shares several features of conventional 2-step LWR core analyses

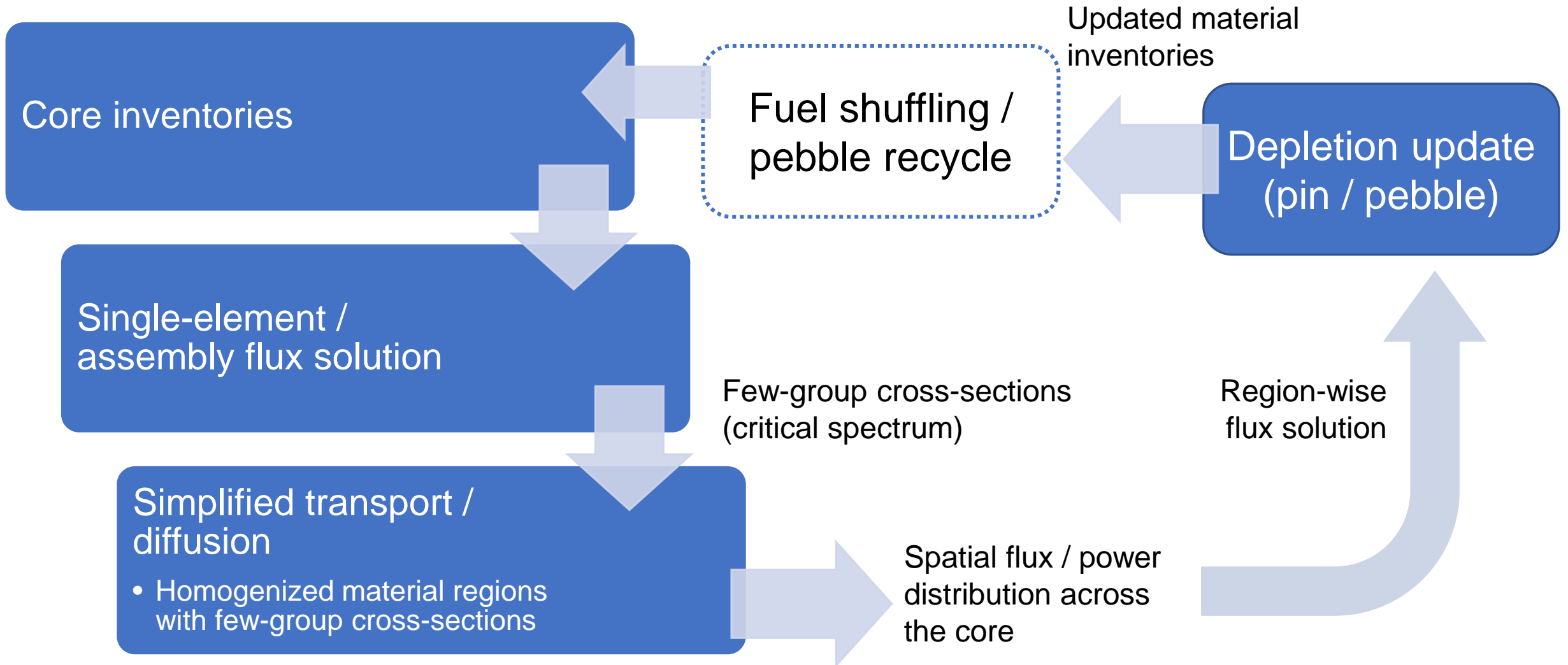

# VSOP calculation flow (MEDUL)

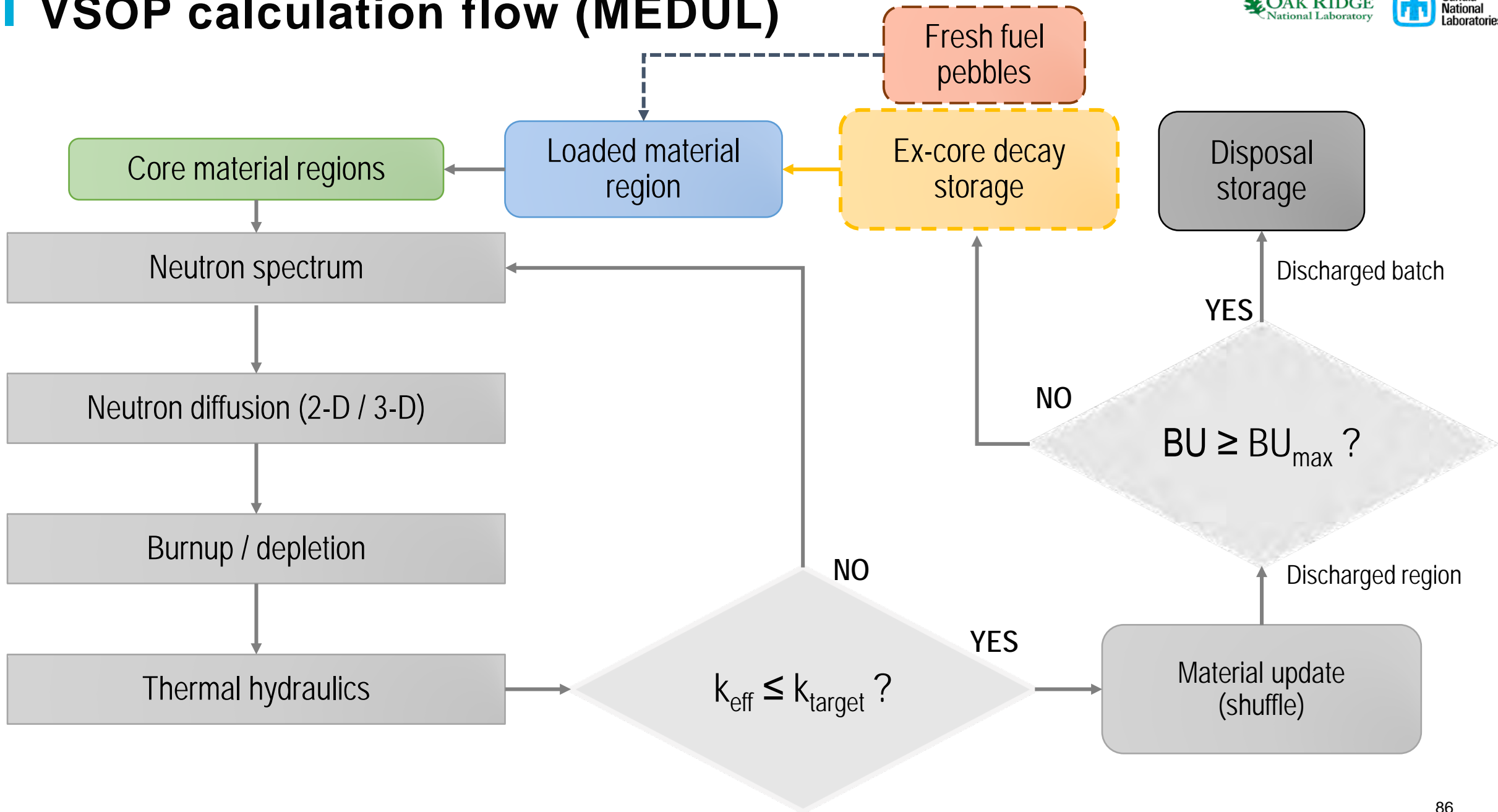

# VSOP calculation flow (MEDUL)

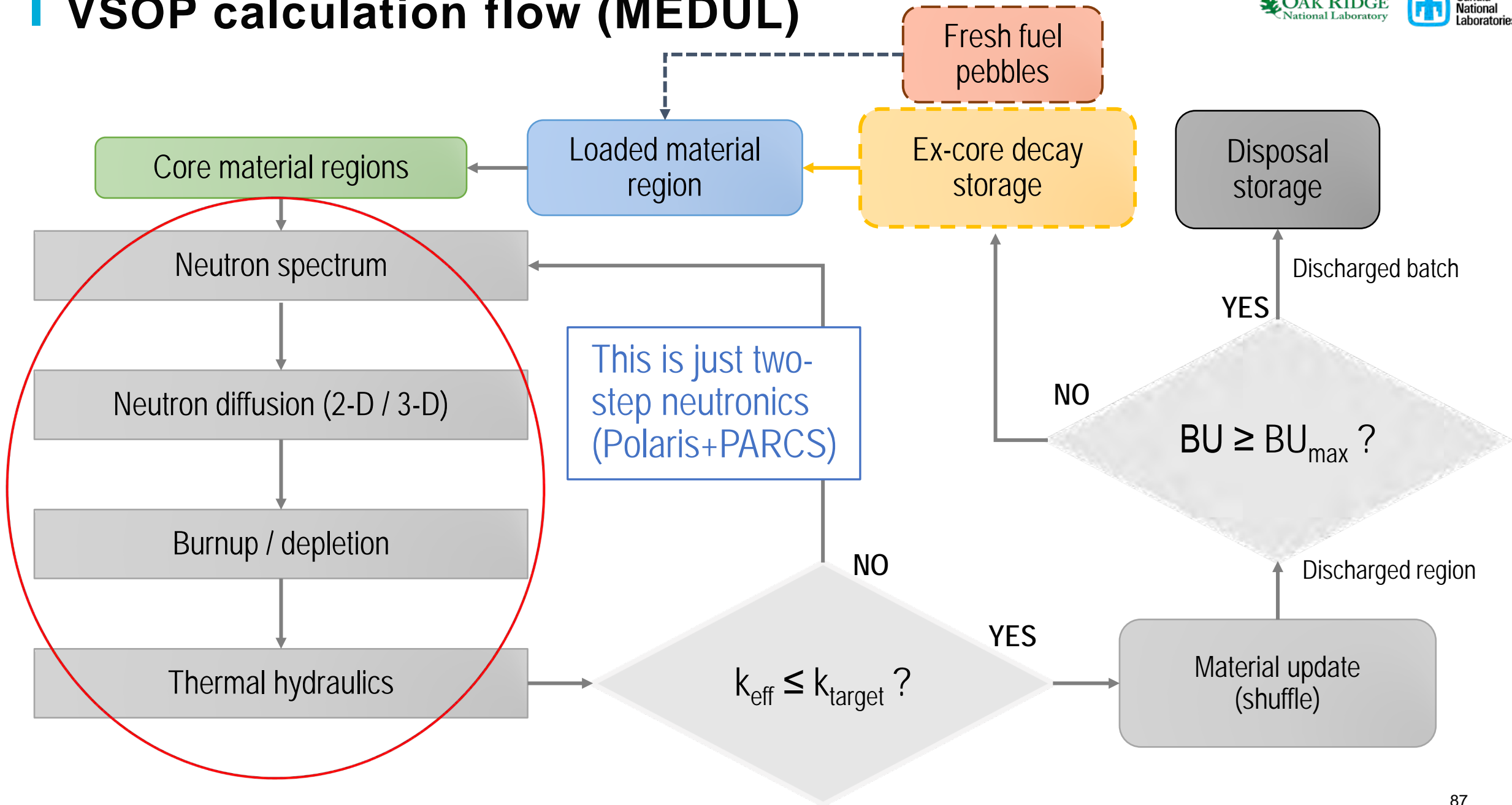

# VSOP calculation flow (MEDUL)

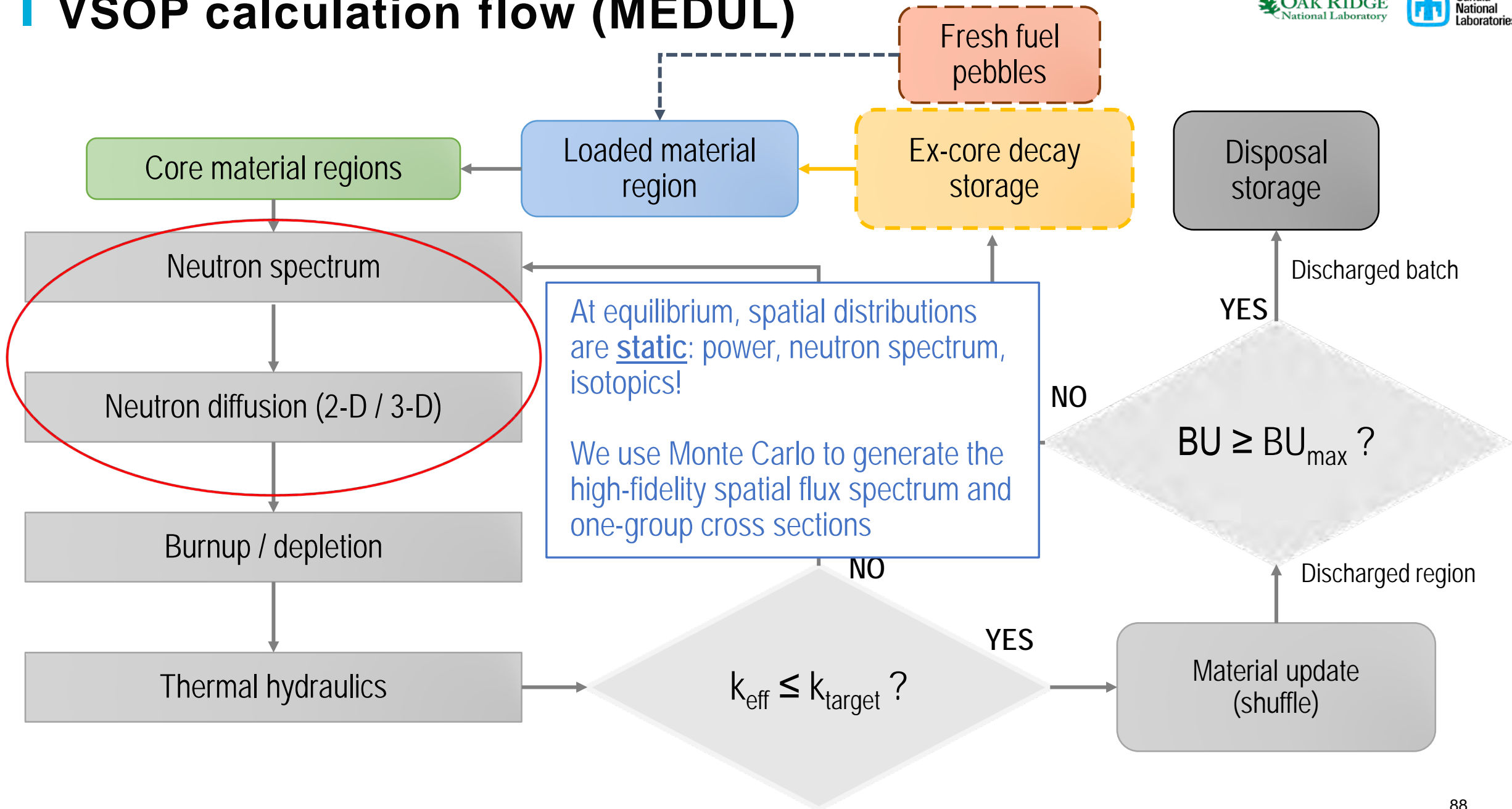



# VSOP calculation flow (MEDUL)

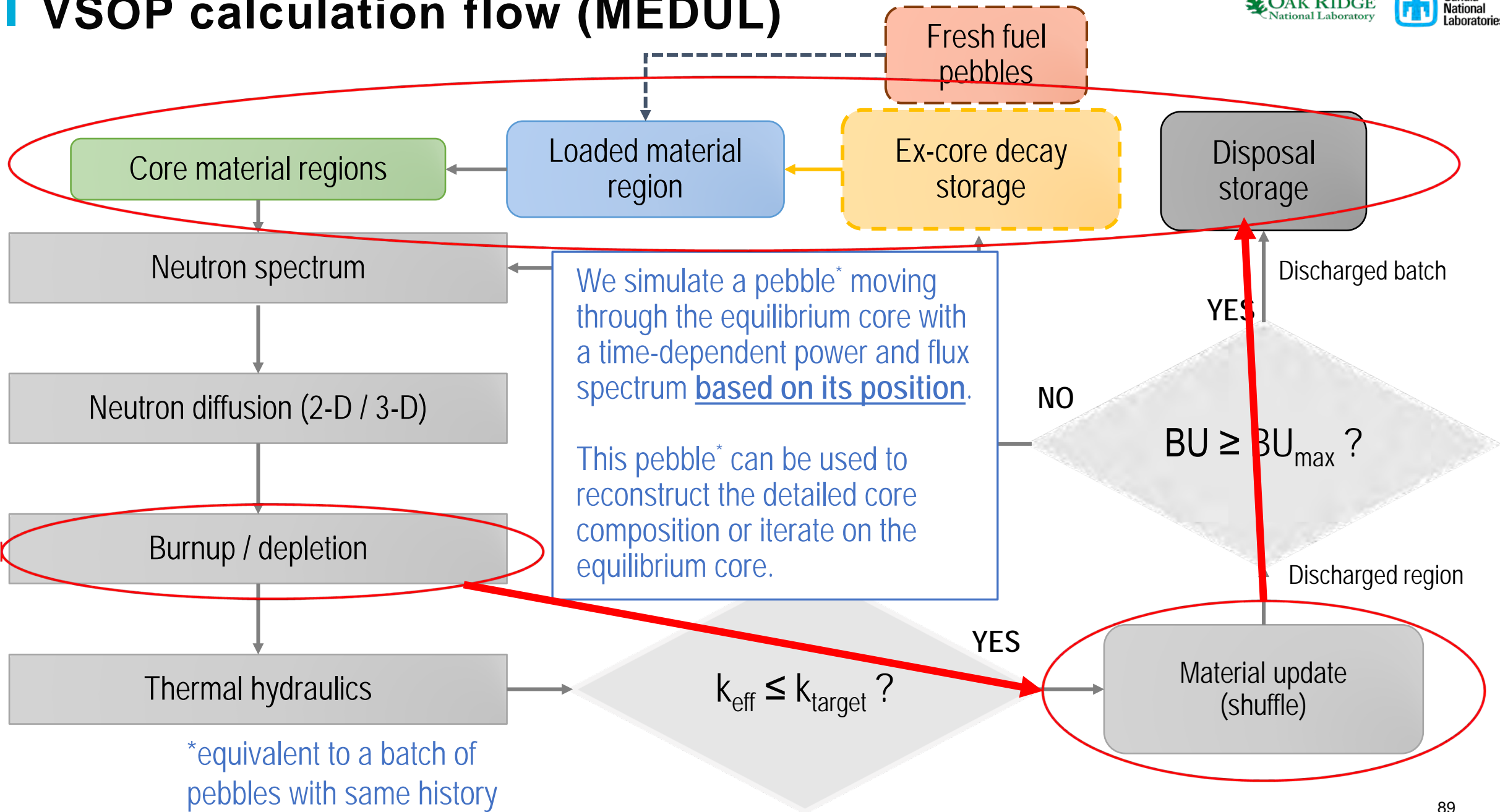

# Iterative procedure for developing equilibrium core compositions

Determine **average burnup** of each pebble batch within a zone (axial / radial)

Deplete each **batch** within zone to its respective burnup

- Origen library based on region-wise flux from core transport

Average zone compositions

- Weighted sum of batches

Calculate core power distribution & flux shape by zone

- Generate ORIGEN library for each zone

Repeat on initial guess inventories until  $k_{\text{eff}}$  converges; depleted compositions represent approximate “equilibrium”

# Why use an iterative approach to equilibrium core compositions (instead of 2-step?)

- We're interested in determining equilibrium **compositions** and **flux shape** by region
  - Not trying to perform dynamics or reload analysis; just need equilibrium in-core inventories
- At-equilibrium assumption simplifies analysis
  - Conservative and bounding: i.e., converged upon highest core-averaged burnup (and thus highest fission product inventories)
  - 2-step analysis requires many repeated calculations
    - e.g., 22 axial zones x 5 passes through core => 110 calculations to perform **one** complete cycle! (Still not at equilibrium)
    - Feasible with few-group diffusion, **costly** for MG transport!

# ORIGEN Library Interpolation Backup Slides



**U.S. NRC**



# Aspects of the ORNL methodology for fuel inventory

- Rapid answers to common questions such as
  - What I/Cs/Pu content could I expect in a PBMR-400 pebble at 90 GWd/MTU?
    - a. assuming constant power?
    - b. pass-dependent power?
    - c. during a power maneuver?
    - d. after 4 days of decay?
    - e. after 40 days of decay?
    - f. after 40 years of decay?
    - g. at 80 GWd/MTU?
    - h. in a pebble with +1% enrichment?
- Up-front work required
  - **Sensitivity analysis** of the reactor system to understand the state changes that impact neutron flux spectrum in the fuel (e.g. moderator density in BWR)
  - Running many CPU-hours of TRITON coupled transport+depletion cases to generate a database of 1-group cross sections  $\sigma$  which can be interpolated to a specific state (ORIGEN reactor library)
  - Those libraries can then be used later (in ORIGAMI) to regenerate inventory and reaction rates:

$$RR(t) = \sigma(t) N(t) \phi(t)$$

**Each answer requires a <10 second calc. on a single CPU**

**Why is speed important?** This approach is not just for seeding MELCOR nodalizations. **All back-end analysis** can use this approach: dry storage casks, on-site storage, discharge inventory analysis, transportation packages.

### Why do it this way?

If  $\sigma$  is insensitive to decay time, power level, then b through h can be answered from a single TRITON pre-calculation!

# Strategy for LWRs

- Increasing fidelity ↑
- What level of TRITON model fidelity is required to generate a reasonable 1-group xs database (ORIGEN reactor library) for rapid **LWR** inventory calculations?
    - a. 3D full-core with plant-specific loading pattern ← Requires plant-specific knowledge
    - b. 3D full-core with equilibrium loading pattern ←
    - c. 3D core subset ← Assembly position matters → Imposes additional assumptions or requires too much information!
    - d. 3D single assembly ←
    - e. 2D core subset ←
    - f. **2D single assembly** ← Has trouble with local variations (control elements, water holes, channel box)
    - g. 2D single pin ←
    - h. 0D infinitely homogeneous mixture ← Has trouble if **any** geometry is important
  - For LWRs, using **2D single assembly** models to generate the 1-group xs database appears sufficient!
    - **verification** confirms ORIGAMI reproduces TRITON results with same (simple) operating history
    - **validation** against spent fuel inventory and decay heat measurements confirms the overall approach is adequate
      - code results generally within experimental uncertainty bands
      - <1% error in decay heat, <5% error in important nuclides, <15% error in others

# Strategy for HTGRs

- What level of TRITON model fidelity is required to generate a reasonable 1-group xs database for rapid **HTGR** inventory calculations?
    - a. 3D full-core with plant-specific pebble loading & discharge strategy
      - ← Requires plant-specific knowledge
      - ← Computationally expensive
    - b. 3D full-core with equilibrium pebble distribution
      - ← Computationally expensive
    - c. 2D core slice with equilibrium pebble distribution
    - d. 1D single pebble with “buffer” for neighbor effects
      - ← Previously investigated in other work; difficult to optimize buffer
    - e. 1D single pebble
      - ← Does not account for reflectors
    - f. 0D infinitely homogeneous mixture
      - ← Does not account for reflectors
- Used in this study to understand sensitivity to model fidelity

- Using at SCALE/TRITON 3D full-core at equilibrium (b) is equivalent to VSOP but with:
  - ENDF/B-VII.1+ modern nuclear data
  - SCALE complete ORIGEN nuclide set instead of VSOP limited set
  - SCALE high-fidelity full-core Monte Carlo transport instead of VSOP diffusion

## Our focus for the PBMR-400

- First, understand the state changes that influence the neutron flux spectrum in a pebble as it flows through an equilibrium core:
  - a. pebble power history
  - b. pebble burnup
  - c. axial position in the core
  - d. radial position in the core (proximity to radial reflector)
  - e. pebble neighbors (burnup/temperature/inventory)
  - f. temperature
  
- Next, **generalize** the SCALE concept of the ORIGEN reactor library for HTGR / PBMR-400

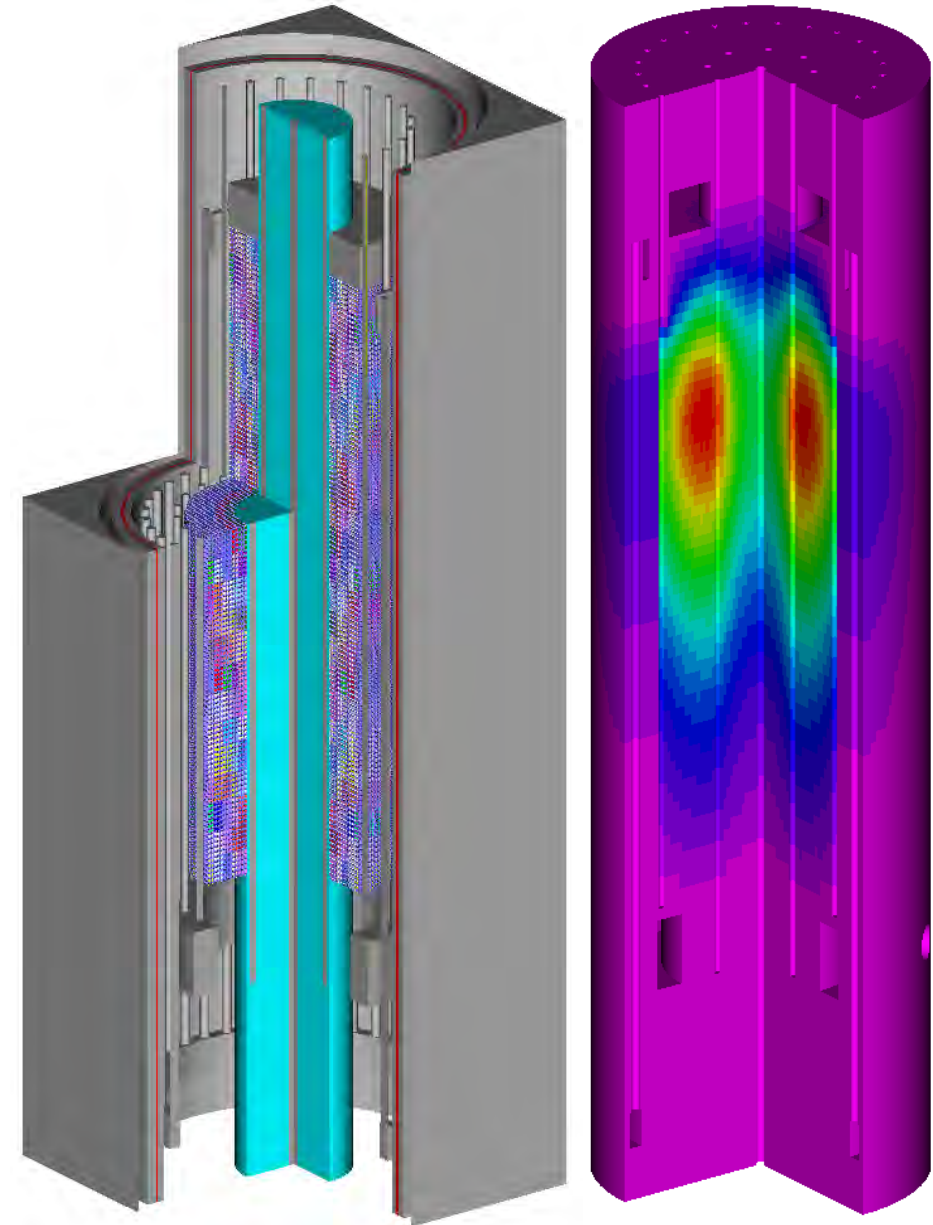



# Prototype ORIGAMI input for multi-pass pebble inventory calculations (SCALE 7.0)

## ORIGAMI operating history input

**radial** power shape

**axial** power shape

(relative) **residence time**  
in each axial zone

Example history: 3-pass  
pebble history, each pass  
moves through declared  
axial zones

**power:** average

MWd/MTU for that pass

**burn:** days at power

**down:** days decay

**rzone:** radial zone

```
pr = [ pr1 pr2 ... pr ]
```

```
pz = [ p1 p2 ... pn ]
```

```
ztime = [ rt1 rt2 ... rtn ]
```

```
hist[
```

```
    pass { power=180    burn=64    down=7    rzone=ANY } 
```

```
    pass { power=160    burn=62    down=6    rzone=ANY } 
```

```
    pass { power=140    burn=64    down=7    rzone=3   } 
```

```
]
```

# Enhancing ORIGEN library interpolation capabilities to accommodate non-LWR systems

- Legacy ORIGEN library interpolation (via ARP) optimized for LWR analysis
  - Interpolation dimensions of initial enrichment, average moderator density, burnup
- Diverse physics characteristics of non-LWR cores require new dimensions for reactor library interpolation
  - e.g., **PBMR**: radial distance from reflector, initial pebble enrichment, reflector temperature
- To address this, we have developed a new HDF5-based format for **self-describing** ORIGEN libraries capable of accommodating arbitrary dimensions for interpolation

# Legacy ORIGEN reactor data library interpolation relies on an ASCII database with hard-coded interpolation dimensions

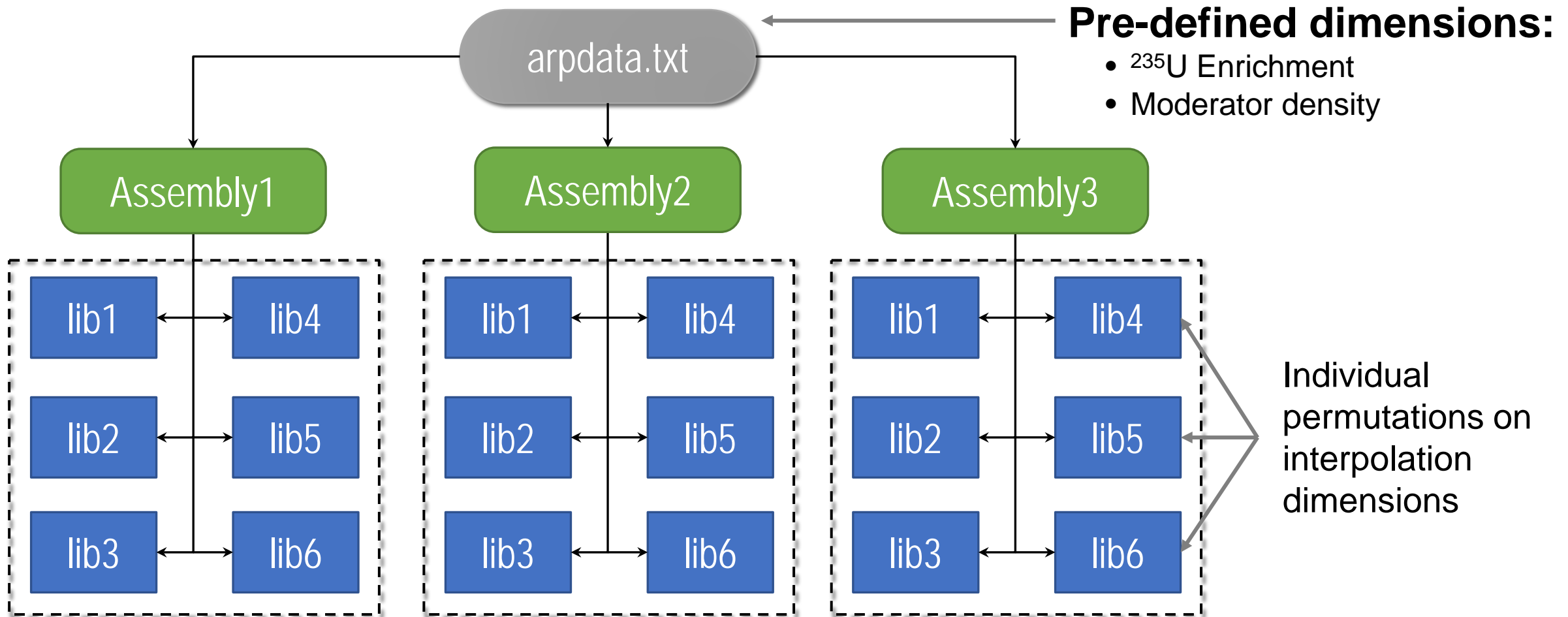

# New HDF5-based “Archive” format designed to accommodate arbitrary interpolation dimensions

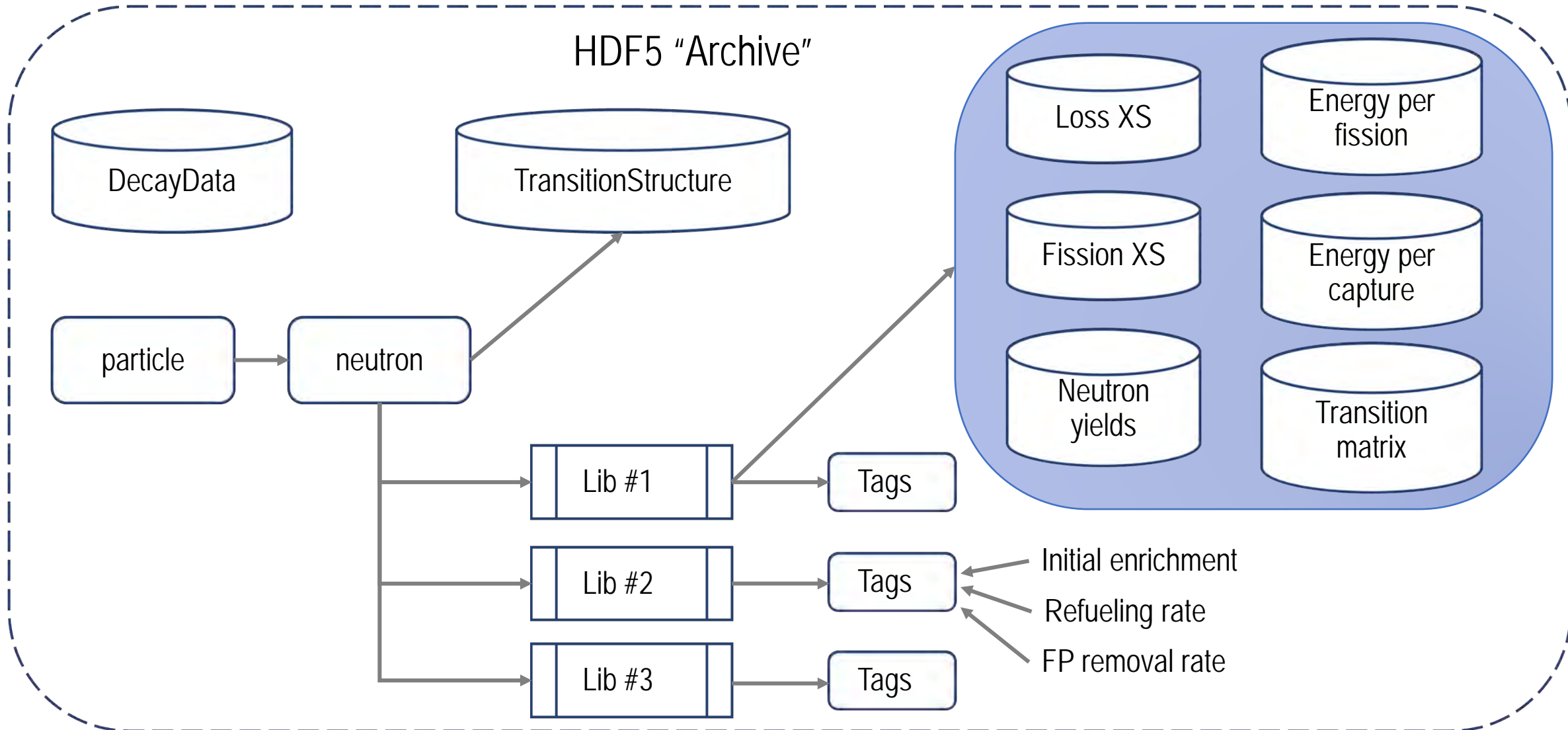

# MELCOR for Accident Progression and Source Term Analysis



**U.S. NRC**

 **OAK RIDGE**  
National Laboratory

 **Sandia**  
National  
Laboratories

# MELCOR Development for Regulatory Applications

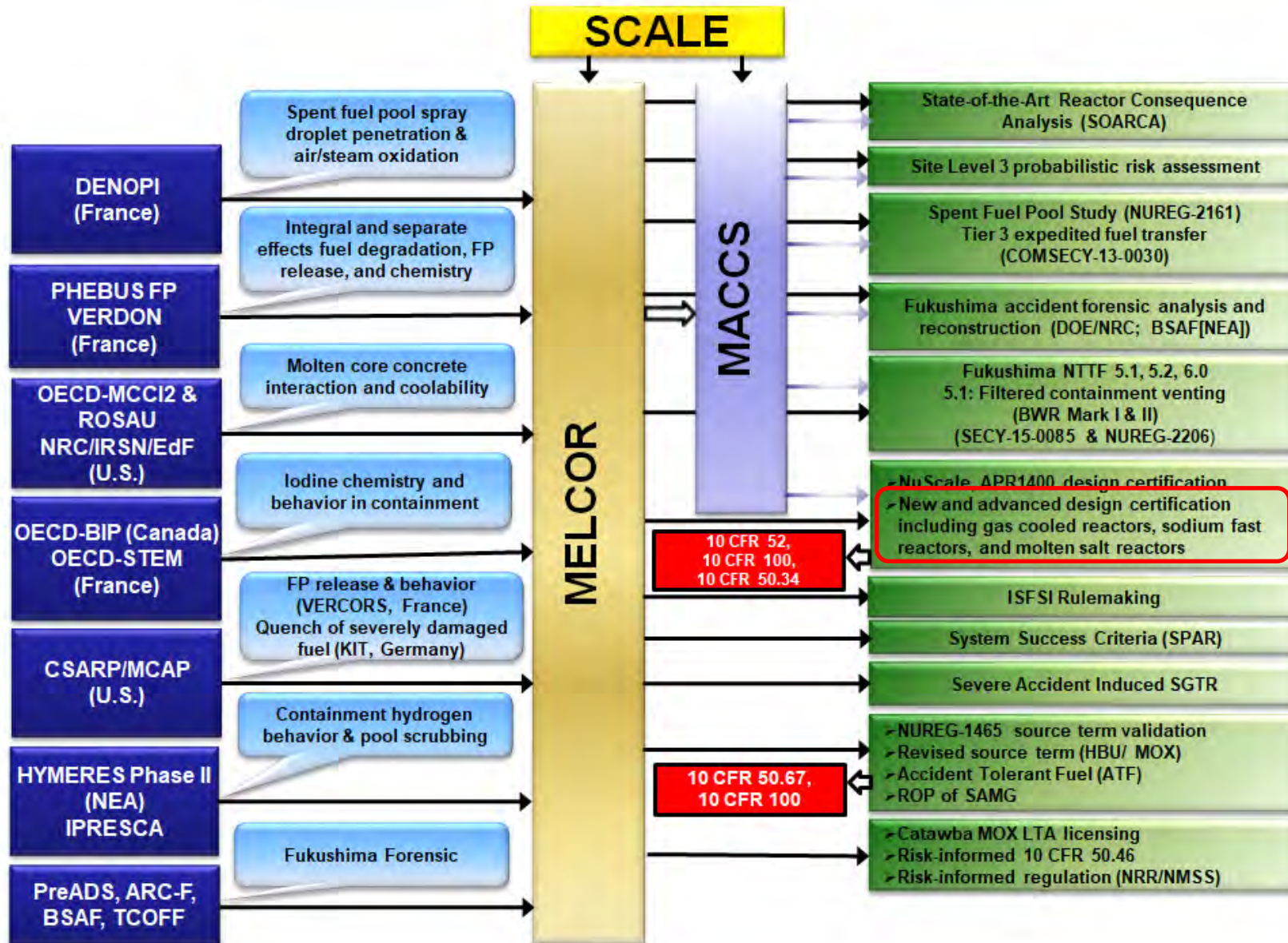

## What Is It?

MELCOR is an engineering-level code that simulates the response of the reactor core, primary coolant system, containment, and surrounding buildings to a severe accident.

## Who Uses It?

MELCOR is used by domestic universities and national laboratories, and international organizations in around 30 countries. It is distributed as part of NRC's Cooperative Severe Accident Research Program (CSARP).

## How Is It Used?

MELCOR is used to support severe accident and source term activities at NRC, including the development of regulatory source terms for LWRs, analysis of success criteria for probabilistic risk assessment models, site risk studies, and forensic analysis of the Fukushima accident.

## How Has It Been Assessed?

MELCOR has been validated against numerous international standard problems, benchmarks, separate effects (e.g., VERCORS) and integral experiments (e.g., Phebus FPT), and reactor accidents (e.g., TMI-2, Fukushima).

# Source Term Development Process

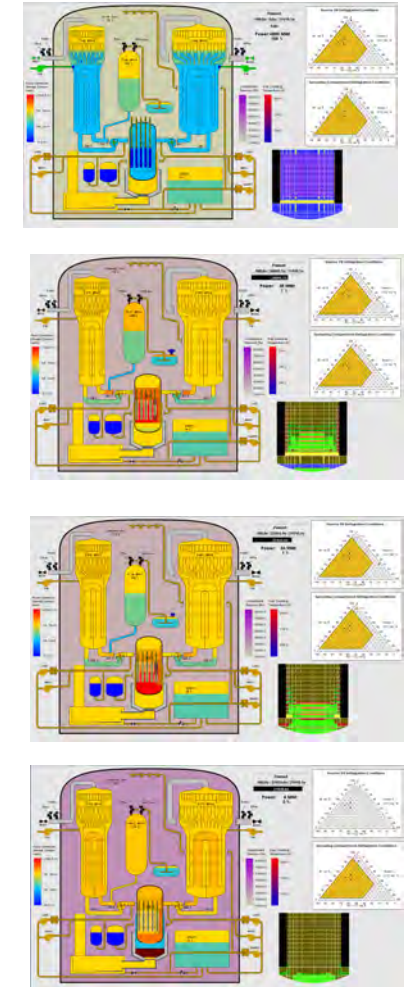
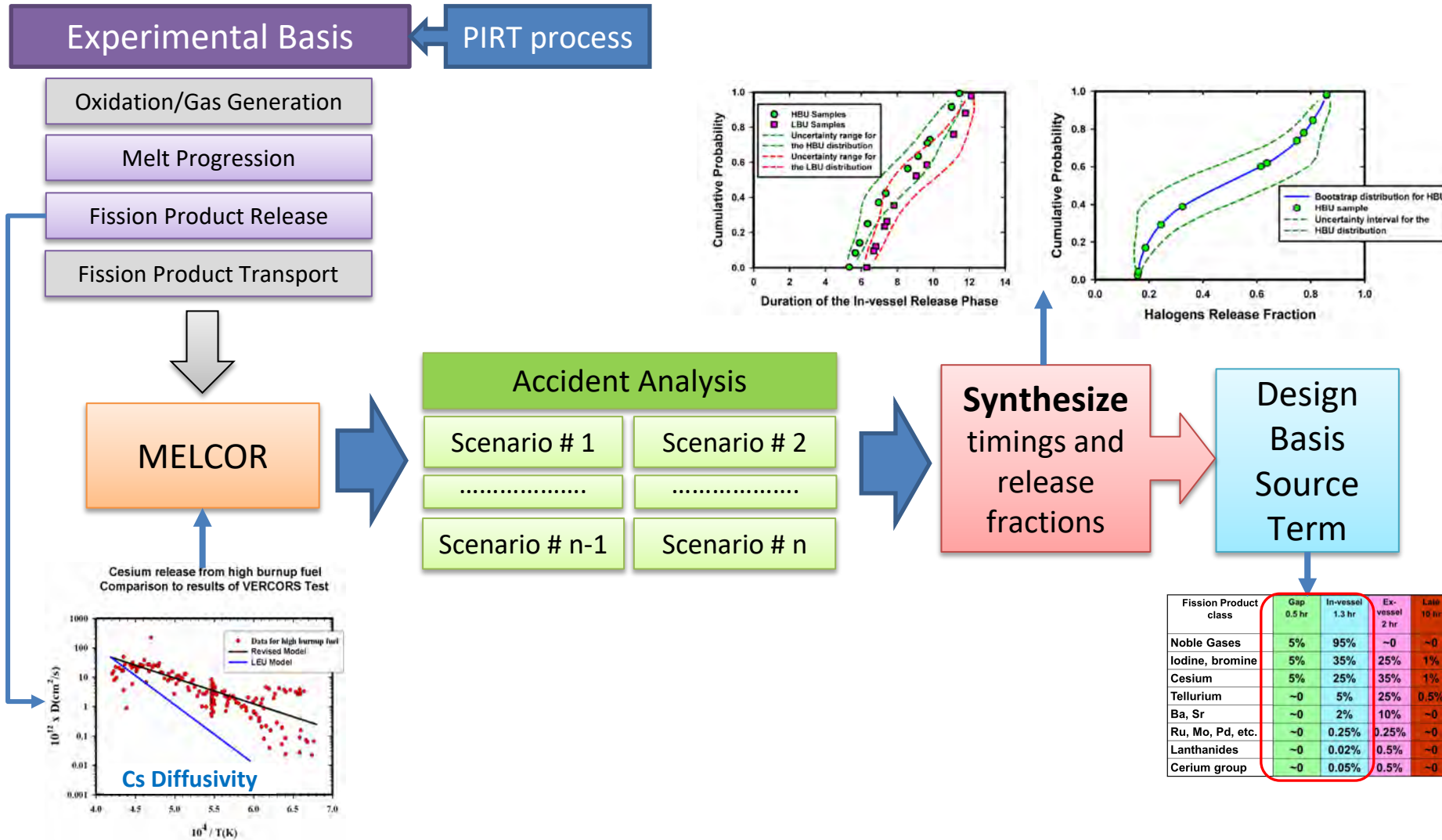

# SCALE/MELCOR/MACCS

## SCALE

### Neutronics

- Criticality
- Shielding
- Radionuclide inventory
- Burnup credit
- Decay heat

## MELCOR

### Integrated Severe Accident Progression

- Hydrodynamics for range of working fluids
- Accident response of plant structures, systems and components
- Fission product transport

## MACCS

### Radiological Consequences

- Near- and far-field atmospheric transport and deposition
- Assessment of health and economic impacts

## Nuclear Reactor System Applications

## Non-Reactor Applications

### Safety/Risk Assessment

- Technology-neutral
  - Experimental
  - Naval
  - Advanced LWRs
  - Advanced Non-LWRs
- Accident forensics (Fukushima, TMI)
- Probabilistic risk assessment

### Regulatory

- License amendments
- Risk-informed regulation
- Design certification (e.g., NuScale)
- Vulnerability studies
- Emergency preparedness
- Emergency Planning Zone Analysis

### Design/Operational Support

- Design analysis scoping calculations
- Training simulators

### Fusion

- Neutron beam injectors
- Li loop LOFA transient analysis
- ITER cryostat modeling
- He-cooled pebble test blanket (H<sup>3</sup>)

### Spent Fuel

- Risk studies
- Multi-unit accidents
- Dry storage
- Spent fuel transport/package applications

### Facility Safety

- Leak path factor calculations
- DOE safety toolbox codes
- DOE nuclear facilities (Pantex, Hanford, Los Alamos, Savannah River Site)



# MELCOR Attributes

## Foundations of MELCOR Development

### Fully integrated, engineering-level code

- Thermal-hydraulic response of reactor coolant system, reactor cavity, reactor enclosures, and auxiliary buildings
- Core heat-up, degradation and relocation
- Core-concrete interaction
- Flammable gas production, transport and combustion
- Fission product release and transport behavior

### Level of physics modeling consistent with

- State-of-knowledge
- Necessity to capture global plant response
- Reduced-order and correlation-based modeling often most valuable to link plant physical conditions to evolution of severe accident and fission product release/transport

### Traditional application

- Models constructed by user from basic components (control volumes, flow paths and heat structures)
- Demonstrated adaptability to new reactor designs – HPR, HTGR, SMR, MSR, ATR, Naval Reactors, VVER, SFP,...

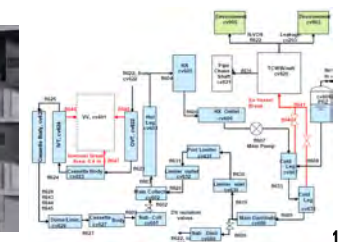
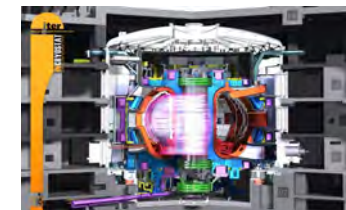
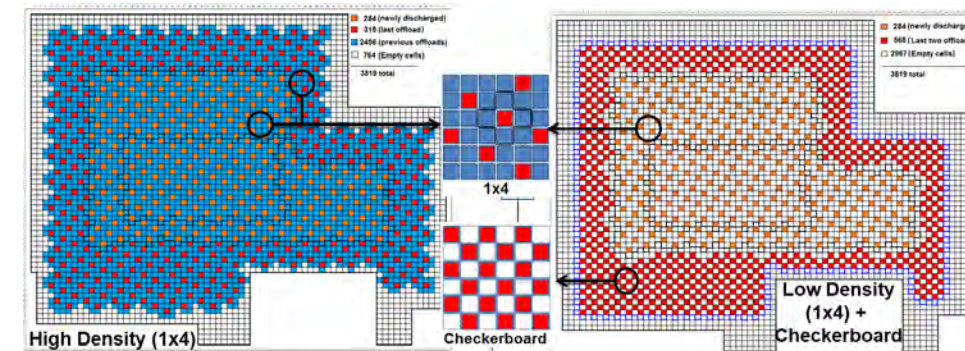
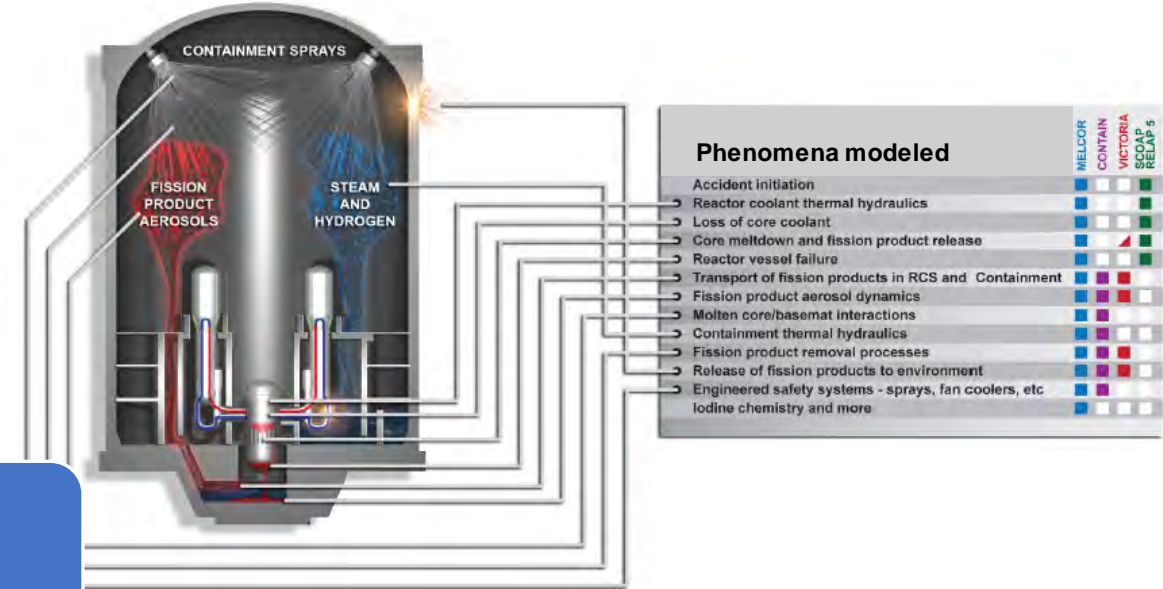

# MELCOR Attributes

## MELCOR Pedigree

### Validated physical models

- International Standard Problems, benchmarks, experiments, and reactor accidents
- Beyond design basis validation will always be limited by model uncertainty that arises when extrapolated to reactor-scale

Cooperative Severe Accident Research Program (CSARP) is an NRC-sponsored international, collaborative community supporting the validation of MELCOR

International LWR fleet relies on safety assessments performed with the MELCOR code

### International Collaboration

Cooperative Severe Accident Research Program (CSARP) – June/U.S.A  
 MELCOR Code Assessment Program (MCAP) – June/U.S.A  
 European MELCOR User Group (EMUG) Meeting – Spring/Europe  
 European MELCOR User Group (EMUG) Meeting – Fall/Asia





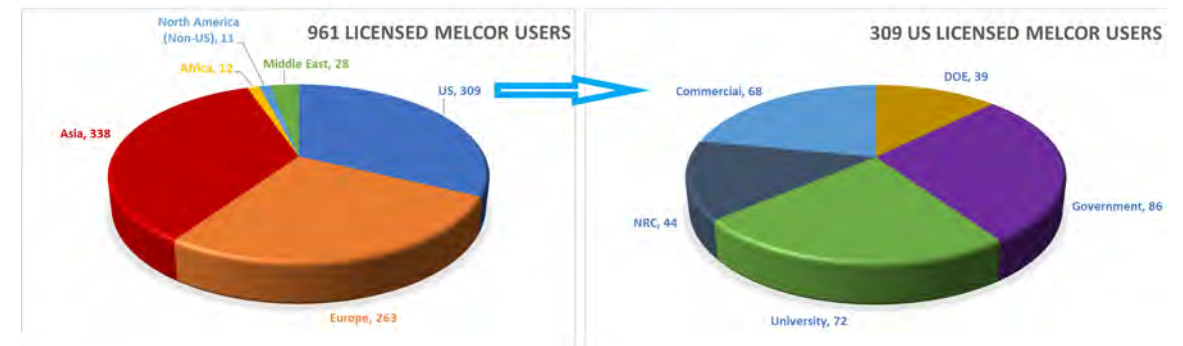

# Common Phenomenology

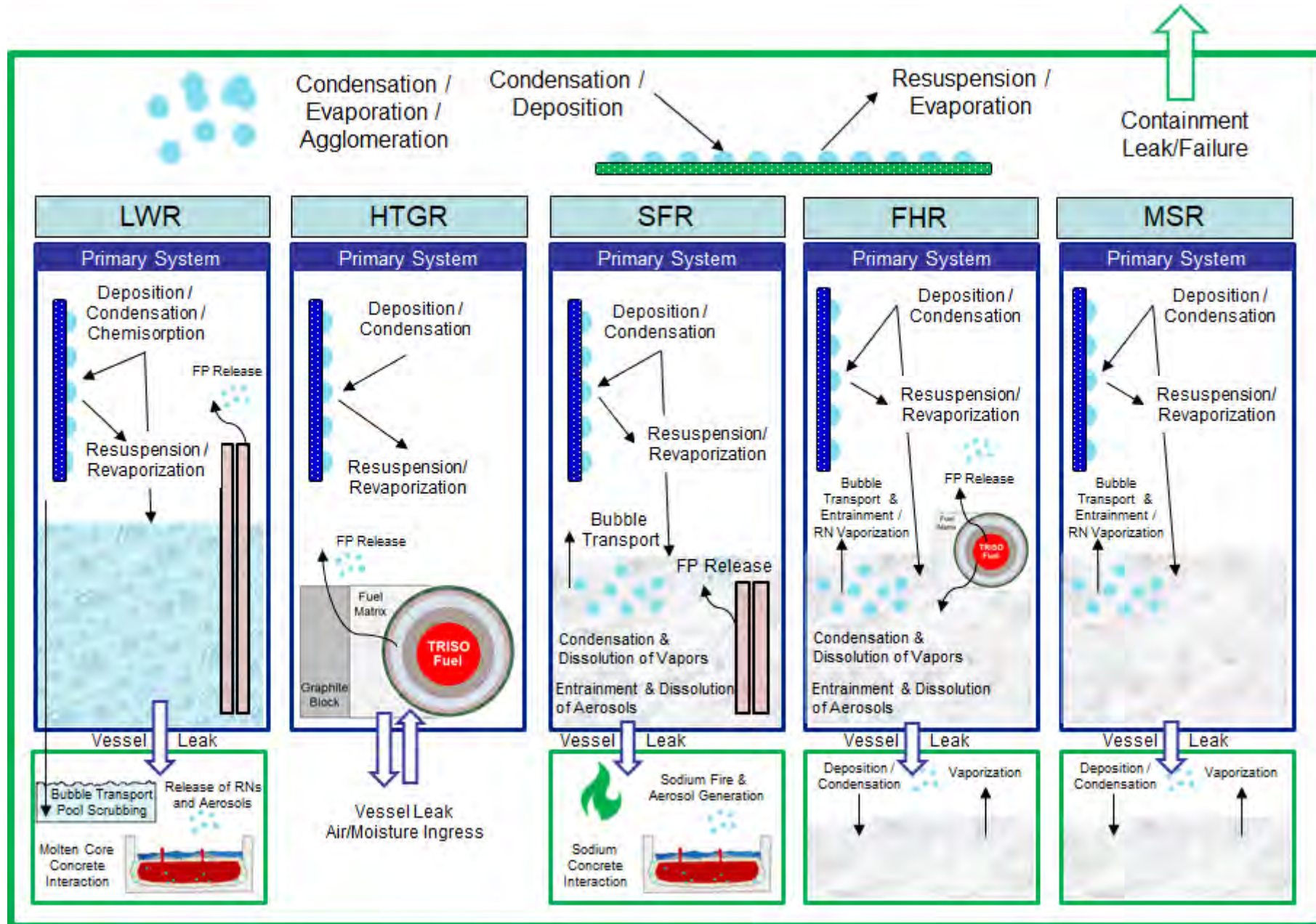

# MELCOR Modeling Approach

Modeling is mechanistic consistent with level of knowledge of phenomena supported by experiments

Parametric models enable uncertainties to be characterized

- Majority of modeling parameters can be varied
- Properties of materials, correlation coefficients, numerical controls/tolerances, etc.

Code models are general and flexible

- Relatively easy to model novel designs
- All-purpose thermal hydraulic and aerosol transport code

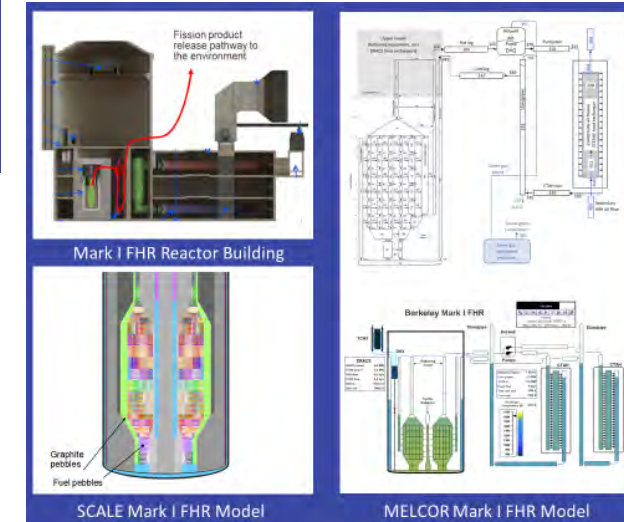
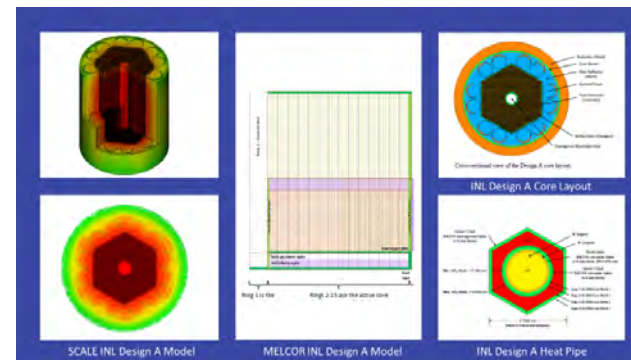
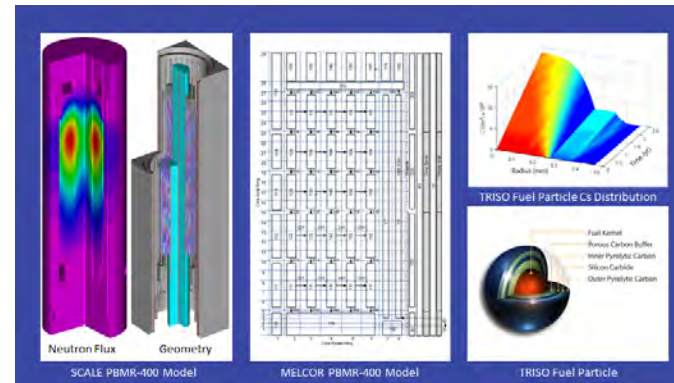
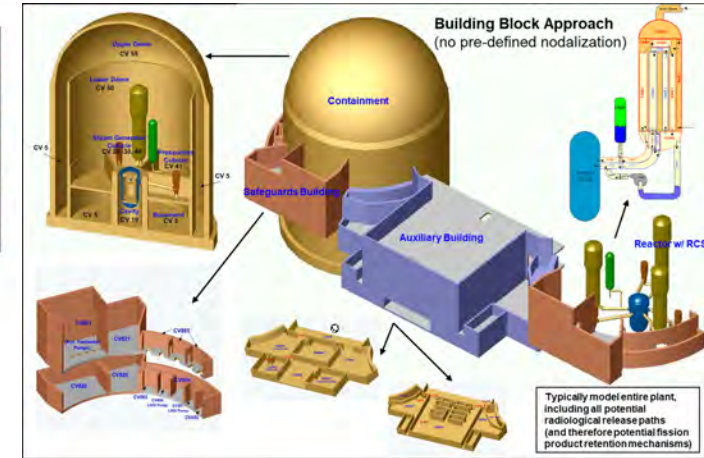
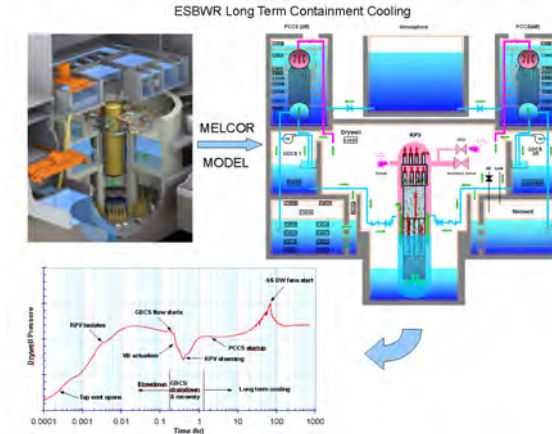

# MELCOR State-of-the-Art

## MELCOR Code Development

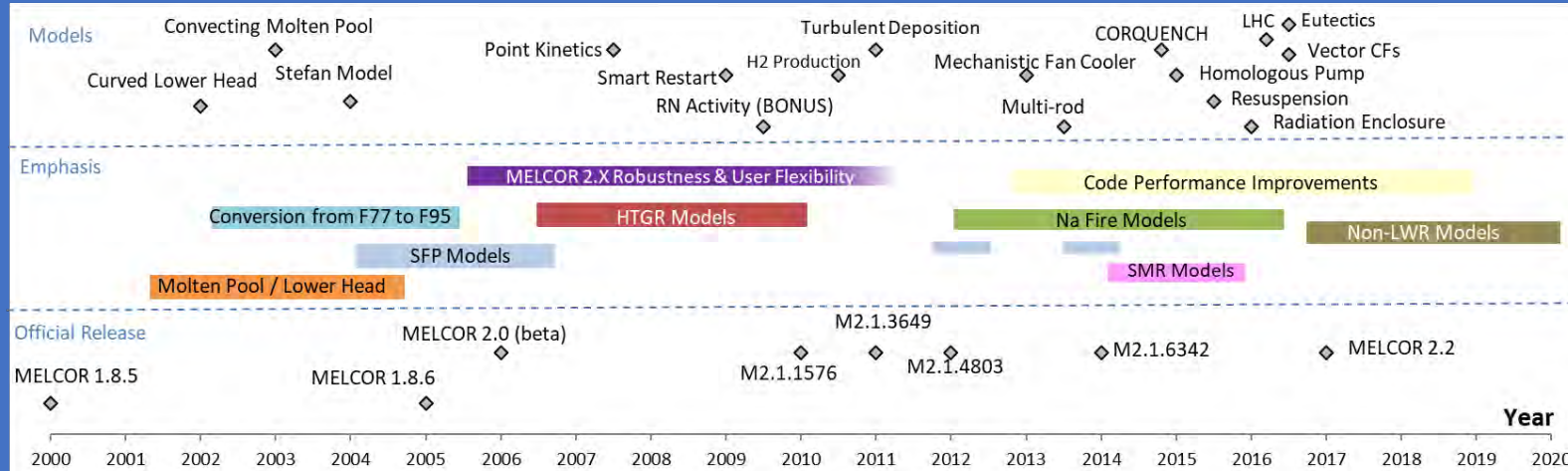

**M2x Official Code Releases**

Version	Date
2.2.18180	December 2020
2.2.14959	October 2019
2.2.11932	November 2018
2.2.9541	February 2017
2.1.6342	October 2014
2.1.4803	September 2012
2.1.3649	November 2011
2.1.3096	August 2011
2.1.YT	August 2008
2.0 (beta)	Sept 2006

**Vacuum vessel**  
 Magnets  
 ▶ 48 magnets  
 Cryostat  
 ▶ The vacuum vessel sits inside the cryostat  
 Blanket  
 ▶ 440 water cooled modules, each 1 m x 1.5 m and ~4 tonnes  
 ▶ Shields vacuum vessel from high energy neutrons and removes heat  
 Divertor  
 ▶ This removes impurities (exhaust) from the plasma  
 ▶ Very high heat loads  
 ▶ At bottom of vacuum vessel

Interactive graphics available: <http://www.iter.org/mach>

Image: <http://www.iter.org/>

### Fusion

- Neutron Beam Injectors (LOVA)
- Li Loop LOFA transient analysis
- ITER Cryostat modeling
- Helium Lithium
- Helium Cooled Pebble Bed Test Blanket (Tritium Breeding)

### Spent Fuel

Spent fuel pool risk studies

Multi-unit accidents (large area destruction)

Dry Storage

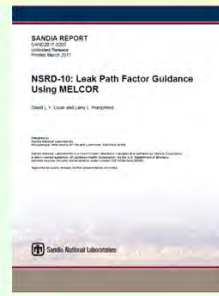
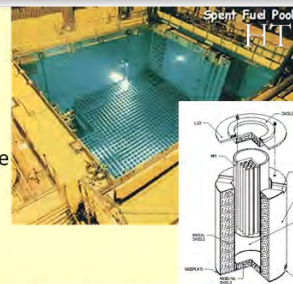

### Non-Nuclear Facilities

- Leak Path Factor Calculations (LPF)
  - Release of hazardous materials from facilities, buildings, confined spaces
- DOE Safety Toolbox code
- DOE nuclear facility users
  - Pantex
  - Hanford
  - Los Alamos
  - Savannah River Site

### HTGR Reactors

- Helium Properties
- Accelerated steady-state initialization
- Two-sided reflector (RF) component
- Modified Fuel components (PMR/PBR)
- Point kinetics
- Fission product diffusion, transport, and release
- TRISO fuel failure

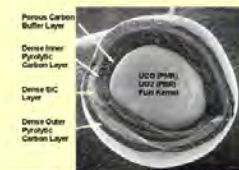

### Sodium Reactors

- Sodium Properties**
- Sodium Equation of State
  - Sodium Thermo-mechanical properties
- Containment Modeling**
- Sodium pool fire model
  - Sodium spray fire model
  - Atmospheric chemistry model
  - Sodium-concrete interaction



### Molten Salt Reactors

- Properties for LiF-BeF2 have been added
  - Equation of State
  - Thermo-mechanical properties

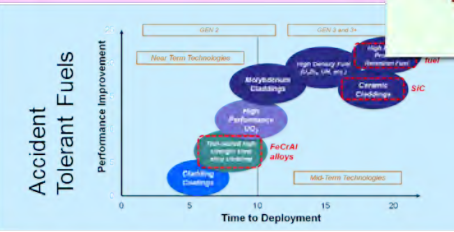

# MELCOR Software Quality Assurance – Best Practices

**MELCOR SQA Standards**  
 SNL Corporate procedure IM100.3.5  
 CMMI-4+  
 NRC NUREG/BR-0167

## MELCOR Wiki

- Archiving information
- Sharing resources (policies, conventions, information, progress) among the development team.

## Code Configuration Management (CM)

- ‘Subversion’
- TortoiseSVN
- VisualSVN integrates with Visual Studio (IDE)

## Reviews

- Code Reviews: Code Collaborator
- Internal SQA reviews

## Continuous builds & testing

- DEF application used to launch multiple jobs and collect results
- Regression test report
- More thorough testing for code release
- Target bug fixes and new models for testing

**Emphasis is on Automation**  
**Affordable solutions**  
**Consistent solutions**



## Bug tracking and reporting

- Bugzilla online

## Code Validation

- Assessment calculations
- Code cross walks for complex phenomena where data does not exist.

## Documentation

- Available on ‘Subversion’ repository with links from wiki
- Latest PDF with bookmarks automatically generated from word documents under Subversion control
- Links on MELCOR wiki

## Project Management

- Jira for tracking progress/issues
- Can be viewable externally by stakeholders

## Sharing of information with users

- External web page
- MELCOR workshops
- MELCOR User Groups (EMUG & AMUG)



Case	BUR	CAV	CF	COR	CVH	DCH	FCL	FDI	FL	HS	NCG	PAR	RN	SPR
M-8-1 NoMix			X		X				X	X	X			
M-8-1 SYM			X		X				X	X	X			
Lace7			X		X	X			X	X	X		X	
Lace8			X		X	X			X	X	X		X	
Vanam-M3			X		X				X	X	X		X	
Molten Salt			X	X	X				X	X	X			
PHEBUS-B9			X	X	X				X	X	X			
FPT1			X	X	X	X			X	X	X		X	
LOFT			X	X	X	X			X	X	X			
Test Inew	X	X	X	X	X	X	X	X	X	X	X	X	X	X
SURRY (LBLOCA)	X	X	X	X	X	X	X	X	X	X	X		X	X
Zion (SBO)		X	X	X	X	X	X	X	X	X	X	X	X	X
PeachBottom (SBO)	X	X	X	X	X	X			X	X	X		X	X
Grand Gulf (SBO)	X	X	X	X	X	X			X	X	X		X	

Table 1-1: Physics Package Coverage

# MELCOR Verification & Validation Basis

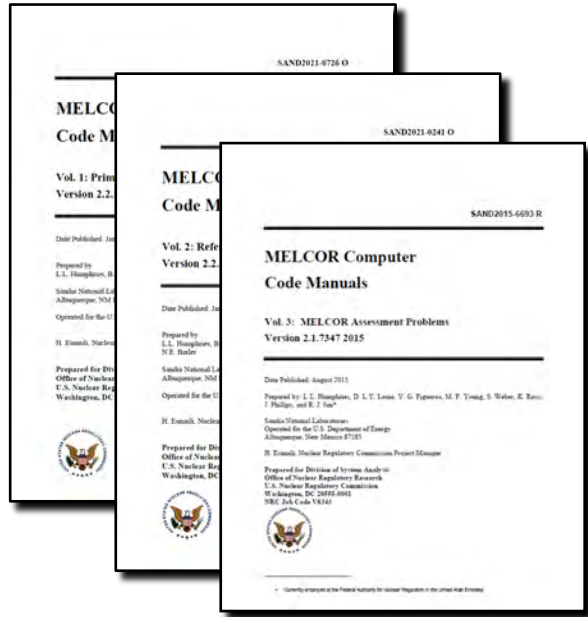

**Volume 1: Primer & User Guide**  
**Volume 2: Reference Manual**  
**Volume 3: MELCOR Assessment Problems**  
 [SAND2015-6693 R]

## Analytical Problems

- Saturated Liquid Depressurization
- Adiabatic Expansion of Hydrogen
- Transient Heat Flow in a Semi-Infinite Heat Slab
- Cooling of Heat Structures in a Fluid
- Radial Heat Conduction in Annular Structures
- Establishment of Flow

LWR & non-LWR applications

Specific to non-LWR application

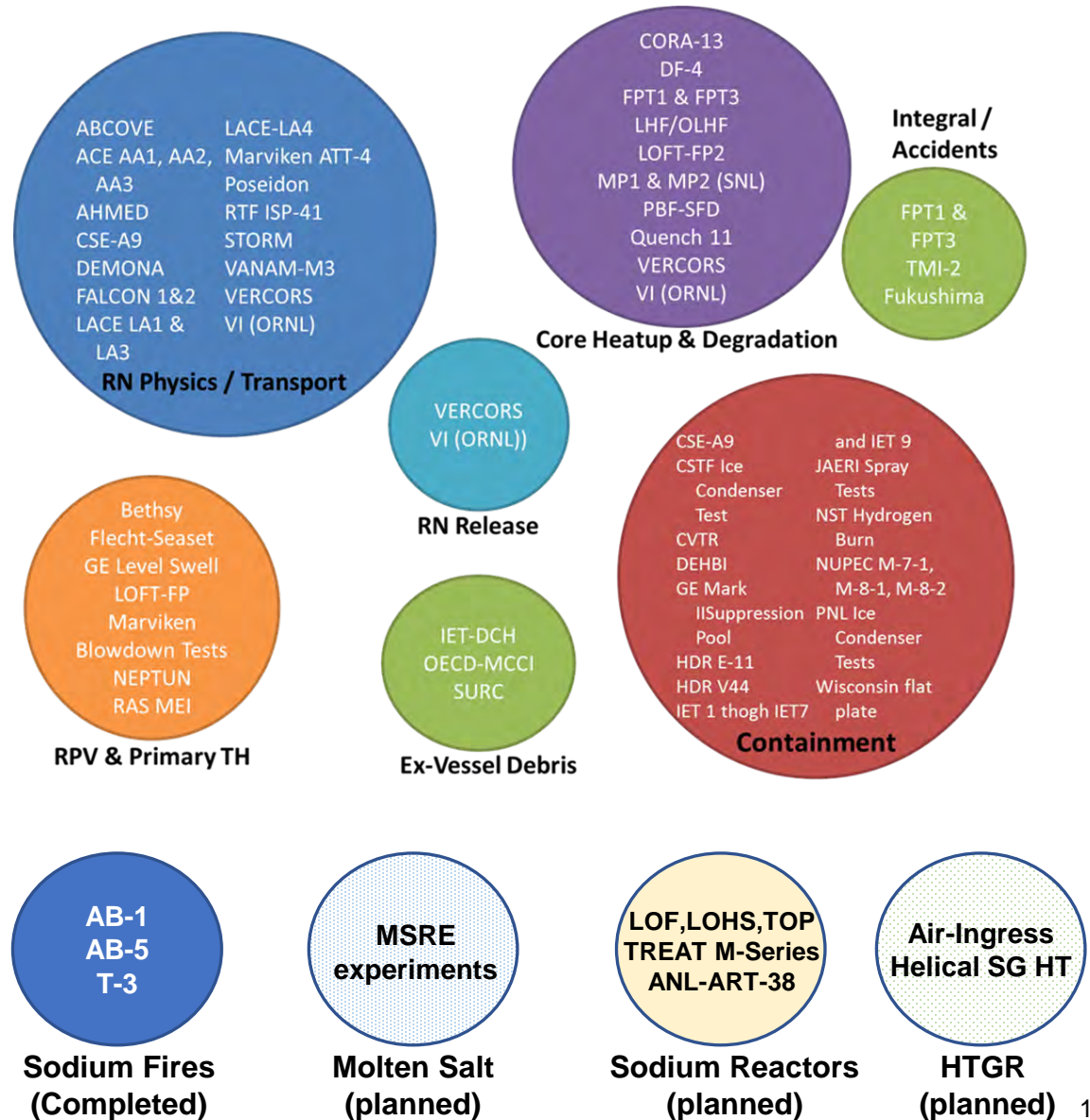

# Sample Validation Cases

## TRISO Diffusion Release

IAEA CRP-6 Benchmark  
Fractional Release

Case	1a	1b	2a	2b	3a	3b
US/INL	0.467	1.0	0.026	0.996	1.32E-4	0.208
US/GA	0.453	0.97	0.006	0.968	7.33E-3	1.00
<b>US/SNL</b>	<b>0.465</b>	<b>1.0</b>	<b>0.026</b>	<b>0.995</b>	<b>1.00E-4</b>	<b>0.208</b>
US/NRC	0.463	1.0	0.026	0.989	1.25E-4	0.207
France	0.472	1.0	0.028	0.995	6.59E-5	0.207
Korea	0.473	1.0	0.029	0.995	4.72E-4	0.210
Germany	0.456	1.0	0.026	0.991	1.15E-3	0.218

- (1a): Bare kernel (1200 °C for 200 hours)
- (1b): Bare kernel (1600 °C for 200 hours)
- (2a): kernel+buffer+iPyC (1200 °C for 200 hours)
- (2b): kernel+buffer+iPyC (1600 °C for 200 hours)
- (3a): Intact (1600 °C for 200 hours)
- (3b): Intact (1800 °C for 200 hours)

A sensitivity study to examine fission product release from a fuel particle starting with a bare kernel and ending with an irradiated TRISO particle;

LACE LA1 and LA3 tests experimentally examined the transport and retention of aerosols through pipes with high speed flow

## Turbulent Deposition

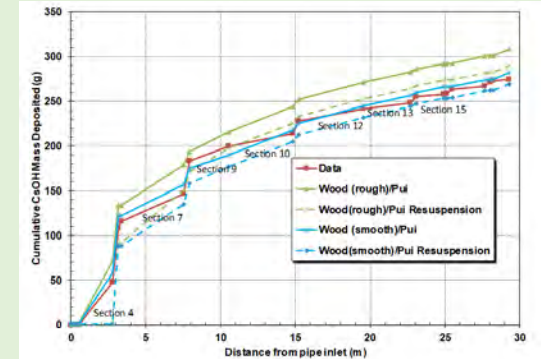
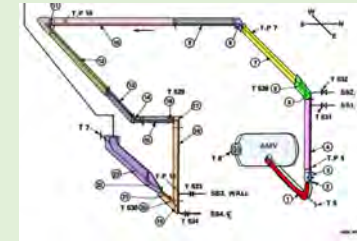

## Aerosol Physics

- Agglomeration
- Deposition
- Condensation and Evaporation at surfaces

### Validation Cases

- Simple geometry: AHMED, ABCOVE (AB5 & AB6), LACE(LA4),
- Multi-compartment geometry: VANAM (M3), DEMONA(B3)
- Deposition: STORM, LACE(LA1, LA3)

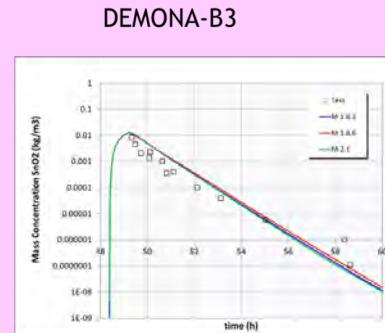
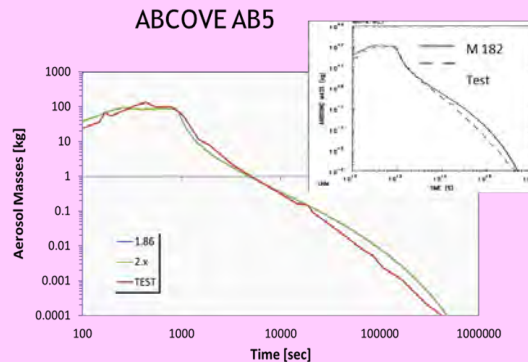

## Resuspension

STORM (Simplified Test of Resuspension Mechanism) test facility

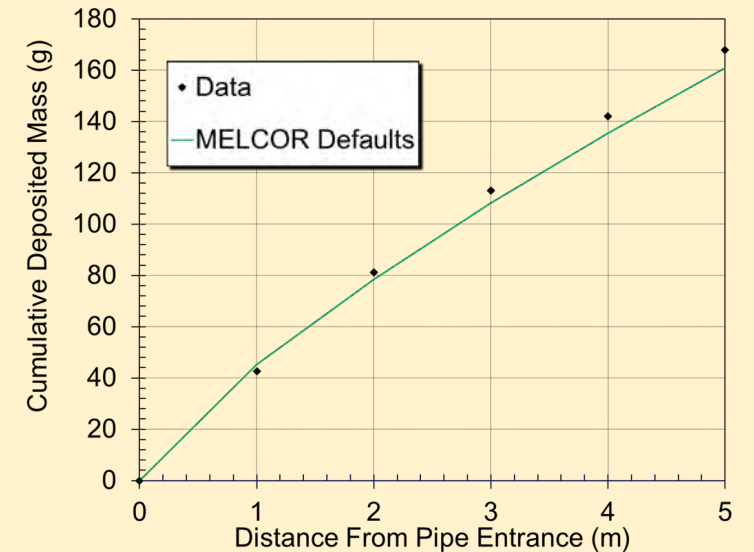



# MELCOR Modernization

Generalized numerical solution engine

Hydrodynamics

In-vessel damage progression

Ex-vessel damage progression

Fission product release and transport

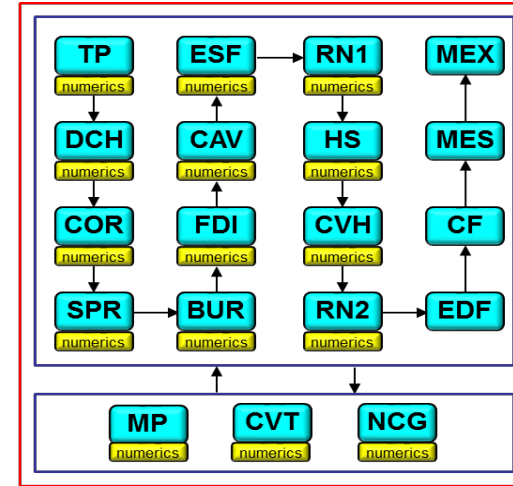

TP = Transfer Process  
 DCH = Decay Heat  
 COR = Core  
 SPR = Containment Spray  
 BUR = Gas Combustion  
 FDI = Fuel Dispersal Interaction  
 CAV = Cavity (MCCI)  
 ESF = Engineered Safety Features  
 MP = Material Properties

RN = Radionuclide  
 HS = Heat Structure  
 CVH = CV Hydrodynamics  
 EDF = External Data File  
 CF = Control Function  
 MES = Special Messages  
 MEX = Executive  
 CVT = CV Thermodynamics  
 NCG = Non Condensable Gas

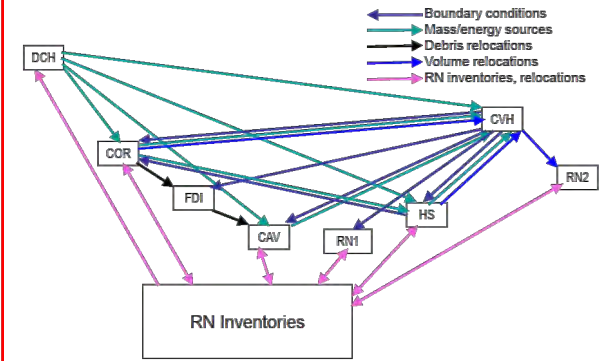

Separate **Physics** & **Numerics**

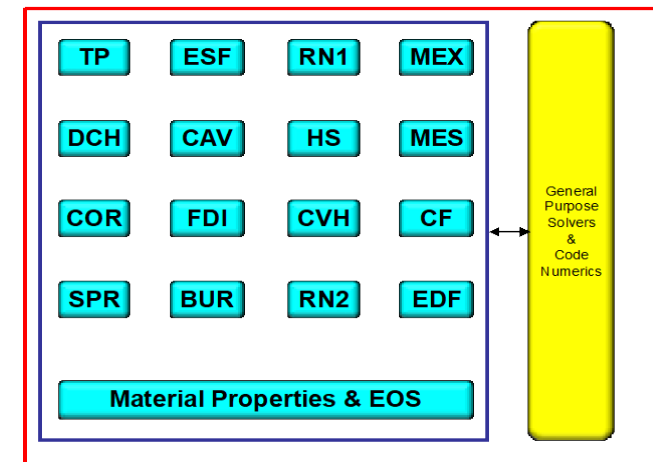
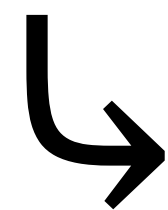

# MELCOR default radionuclide classes



**U.S. NRC**



# MELCOR default radionuclide classes

Class	Class Name	Chemical Group	Representative	Member Elements
1	XE	Noble Gas	Xe	He, Ne, Ar, Kr, Xe, Rn, H, N
2	CS	Alkali Metals	Cs	Li, Na, K, Rb, Cs, Fr, Cu
3	BA	Alkaline Earths	Ba	Be, Mg, Ca, Sr, Ba, Ra, Es, Fm
4	I2	Halogens	I <sub>2</sub>	F, Cl, Br, I, At
5	TE	Chalcogens	Te	O, S, Se, Te, Po
6	RU	Platinoids	Ru	Ru, Rh, Pd, Re, Os, Ir, Pt, Au, Ni
7	MO	Early Transition Elements	Mo	V, Cr, Fe, Co, Mn, Nb, Mo, Tc, Ta, W
8	CE	Tetravalent	Ce	Ti, Zr, Hf, Ce, Th, Pa, Np, Pu, C
9	LA	Trivalent	La	Al, Sc, Y, La, Ac, Pr, Nd, Pm, Sm, Eu, Gd, Tb, Dy, Ho, Er, Tm, Yb, Lu, Am, Cm, Bk, Cf
10	UO2	Uranium	UO <sub>2</sub>	U
11	CD	More Volatile Main Group	Cd	Cd, Hg, Zn, As, Sb, Pb, Tl, Bi
12	AG	Less Volatile Main Group	Ag	Ga, Ge, In, Sn, Ag