



Flow Control Division

*Anchor/Darling Valves
BW/IP Valves
Edward Valves
Valtek Control Products
Worcester Valves*

February 25, 2013

US Nuclear Regulatory Commission
Document Control Desk
11545 Rockville Pike
Rockville MD 20852-2746

Subject: Wedge Pin Failure of an Anchor/Darling Double- Disc Gate Valve at Browns Ferry Nuclear Plant Unit 1

Reference: Tennessee Valley Authority's 10CFR Part 21 Notification Letter Dated January 4, 2013 and Flowserve Letter to the NRC dated January 25, 2013.

Attachment 1: Recommended Stem Pre-Torque for Stem Upper Wedge
Attachment 2: List of Potentially Affected Customers and Plants

Gentlemen:

This is to notify the US Nuclear Regulatory Commission that, in accordance with the provisions of 10CFR Part 21, we have identified a potential issue and are submitting our evaluation of the event.

Flowserve has been working with the Tennessee Valley Authority's (TVA) Browns Ferry Nuclear Plant to investigate the failure of a Size 10, Class 900 Anchor/Darling motor-operated double-disc gate valve. The failure was due to the shearing of the wedge pin which serves a joint locking function at the threaded interface between the valve stem and upper wedge. The pin is designed to ensure that the joint does not loosen due to vibration and other secondary loads. On some valve designs, the pin also is used to attach the disc retainers to the upper wedge. The pin shearing allowed rotation of the stem during the closing stroke when the valve was seating and ultimately resulted in loss of the stem to upper wedge joint integrity.

Flowserve has completed an evaluation of the failure and concluded the root cause of the wedge pin failure was excessive load on the pin. The stem operating torque exceeded the torque to tighten the stem into the upper wedge before installation of the wedge pin. The additional stem torque produced a load on the wedge pin creating a stress which exceeded the pin shear strength causing the failure. The recommended assembly stem torque did not envelope the operating torque for the TVA application providing the potential for an over load situation and ultimate failure. The operating torque for the TVA valve was unusually high due to the fast closing time of the actuator and very conservative closing thrust margin.

JEI9
NRC

This situation can potentially occur on any Anchor/Darling type double-disc gate valve with a threaded stem to upper wedge connection, typically size 2.5" and larger, operated by an actuator that applies torque on the stem to produce the required valve operating thrust. An operating stem torque greater than the assembly stem torque can provide the opportunity for excessive pin load and potentially failure.

The stems on most double-disc (DD) gate valves larger than size 2" are attached to the upper wedge using UN threads. A pin is installed through the hub of the upper wedge and stem threaded section to prevent the stem from loosening and eventually unscrewing from the wedge. In addition, the disc retainers on some DD gate valves are attached using the wedge pin. See Figure 1. The output torque of the actuator is transmitted to the stem/wedge joint through the stem and is resisted by the disc wedge pack, therefore the stem to wedge connection is loaded by the stem torque and thrust. The wedge pin is not designed to withstand the full actuator output torque. The actuator torque direction tends to tighten the stem into the wedge during closing and tends to loosen the stem during opening.

Figure 1
Typical Double-Disc Gate Valve Trim

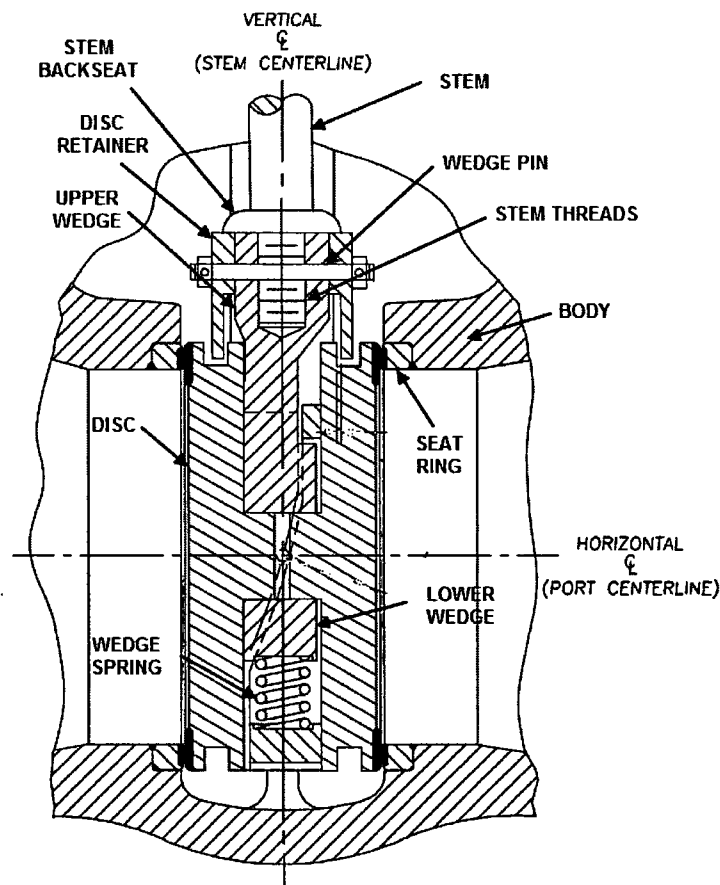

Anchor Darling double-disc gate valves have been supplied to the commercial nuclear industry for critical service since the early 1970's. In April 1996, a specific stem preload torque value was established based on valve size and pressure class. This recommended standard stem preload torque is based on a calculated, required stem thrust to close the valve which is considered great enough to envelope most applications. Attachment 1 details the recommended torque by valve size and pressure class.

Failure of the wedge pin can cause loosening of the stem in the upper wedge and eventually separation of the stem leaving the valve inoperable. For certain designs pin failure could allow the retainers and miscellaneous attachment parts to fall out of position and become loose parts in the valve and piping system.

We have reviewed our records, and the only similar wedge pin failure that we can identify, in addition to the Browns Ferry problems, is a sheared wedge pin at LaSalle Nuclear Station in 1993. Our investigation of the LaSalle failure concluded that the wedge pin failed due to excessive torque in the opening direction due to bonnet over pressurization.

Flowserve recommends that all critical Anchor/Darling Double-Disc Gate valves with threaded stem to upper wedge connections and actuators that produce a torque on the stem be evaluated for potential wedge pin failure. Valves with electric motor actuators which produce high output torques are the most susceptible to failure. Valves which were assembled with stem torques that exceed the operating torque are not candidates for failure.

There is no test or inspection method to determine if the stems were completely torqued into the upper wedge prior to pin installation. Abnormal rotation of the stem immediately after valve seating or unseating, short valve stroke, or poor, unusual operation are signs of possible issues and should be investigated. Valve stems which have any gap between the stem backseat and top of the upper wedge need to be re-torqued. Valves with operating torques greater than the stem installation torque should be corrected by increasing the stem installation torque to at least the maximum expected operating stem torque. As provided in the Anchor/Darling 12/05 instruction manual, the existing stem can be reused by torquing and drilling for a new pin if it is greater than 1.50" diameter and not reused previously. Stems of 1.50" and less diameter or stems which cannot be re-drilled for a new pin should be replaced.

Attachment 2 is a list, based on our records, of customers, utilities and nuclear plants which were supplied with Anchor/Darling Double-Disc Gate valves with motor actuators on contracts with ASME Section III and/or 10CFR21 imposed.

Flowserve plans to provide each of the customers identified in Attachment 2 with a copy of this notification letter.

Please do not hesitate to contact me if you have questions or require additional information.

Respectfully submitted,

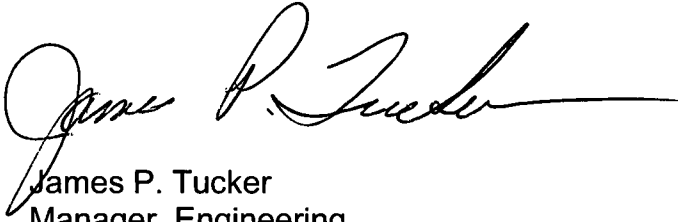
A handwritten signature in black ink, appearing to read "James P. Tucker". The signature is fluid and cursive, with a long horizontal stroke extending to the right.

James P. Tucker
Manager, Engineering
Flowserve Corporation
Flow Control Division
1900 S. Saunders St.
Raleigh, NC 27603

ATTACHMENT 1

RECOMMENDED STEM PRE-TORQUE (FT-LBS) FOR STEM/UPPER WEDGE JOINT ANCHOR-/ DARLING DOUBLE-DISC GATE VALVES

VALVE	PRESSURE CLASS					
SIZE	150	300	600	900	1500	2500
2.5	11	13	21	38	60	114
3	17	16	26	48	89	171
4	25	28	57	82	154	292
6	42	57	139	228	414	844
8	46	104	275	444	805	1848
10	74	172	483	776	1497	3436
12	110	262	720	1240	2467	5436
14	156	380	1022	1726	3434	7409
16	215	528	1398	2346	4844	9699
18	289	770	1955	3250	6888	12394
20	377	1006	2496	2960	9003	15750
22	448	1355	N/A	N/A	N/A	N/A
24	604	1697	3724	6999	14154	25132

ATTACHMENT 2

<u>ANCHOR/DARLING DOUBLE-DISC GATE VALVES WITH WEDGE PINS AND MOTOR ACTUATORS</u>	
<u>AE / UTILITY</u>	<u>NUCLEAR PLANT</u>
B&W	THREE MILE ISLAND 2
BECHTEL	ANO 1, CALLAWAY, WOLF CREEK, MILSTONE
CFE	LAGUNA VERDE
COM ED	DRESDEN, LASALLE, QUAD CITIES
CPL	BRUNSWICK, ROBINSON
DOMINION	SURRY
DUKE	CATAWBA, OCONEE
EBASCO	MILLSTONE
ENTERGY	GRAND GULF, NINE MILE, WATERFORD
EXELON	PEACH BOTTOM,
FPL	CRYSTAL RIVER, ST. LUCIE
GE	BROWNS FERRY, BRUNSWICK, CHINSHAN, CLINTON, COLUMBIA, CONFENTES
GE	COOPER, DUANE ARNOLD, FITZPATRICK, FORT CALHOUN, FUKISHIMA
GE	GRAND GULF, HATCH, KUOSHENG, LAGUNA VERDE, LASALLE, LIMERICK
GE	NINE MILE, PEACH BOTTOM, PERRY, PILGRIM, RIVER BEND, SHIMANE
GPC	HATCH
GPU	OYSTER CREEK
GULF STATES	RIVER BEND
ILL POWER	CLINTON
INDIANA MICH POWER	COOK
MAINE YANKEE	MAINE YANKEE
NEU	MILLSTONE
NIAGARA MOHAWK	NINE MILE
NORTHEAST NUC	MILLSTONE
NPPD	COOPER
NSP	MONTICELLO, PRARIE ISLAND
NYPA	FITZPATRICK
ONT HYDRO	BRUCE
PG&E	DIABLO CANYON
PHILA ELECTRIC	PEACH BOTTOM
PPL	SSES
PROGRESS ENERGY	ROBINSON
SCE	SAN ONOFRE
SCE&G	VC SUMMER
SNC LAVALIN	BRUCE

TPC	CHINSHAN, KUOSHENG, LUNG MEN
TVA	BROWNS FERRY
VEPCO	NORTH ANNA, SURRY
VERMONT YANKEE	VERMONT YANKEE
WESTINGHOUSE	COOK, DIABLO CANYON, INDIAN POINT, KANSAI ELECTRIC, KEWAUNEE
WESTINGHOUSE	KORI 1, NORTH ANNA, POINT BEACH, PRAIRIE ISLAND, RINGALS, ROBINSON