



STEVEN D. CAPPS
Vice President
McGuire Nuclear Station

Duke Energy
MG01VP / 12700 Hagers Ferry Rd.
Huntersville, NC 28078

980-875-4805
980-875-4809 fax
Steven.Capps@duke-energy.com

October 25, 2012

10 CFR 50.54(f)

U. S. Nuclear Regulatory Commission
Attn: Document Control Desk
Washington, DC 20555-0001

Subject: Duke Energy Carolinas, LLC (Duke Energy)
McGuire Nuclear Station, Units 1 and 2
Docket Nos. 50-369 and 50-370
Response to NRC Bulletin 2012-01

Reference:

1. NRC Bulletin 2012-01: Design Vulnerability in Electric Power System, dated July 27, 2012

On July 27, 2012, the Nuclear Regulatory Commission issued NRC Bulletin 2012-01 "Design Vulnerability in Electric Power System" to all power reactor licensees and holders of combined licenses for nuclear power reactors. The purpose of this bulletin is to notify Licensees of a recent operating experience concerning the loss of one of the three phases of the offsite power circuit at Byron Station, Unit 2 in order to determine if further regulatory action is warranted. NRC Bulletin 2012-01 requires that each licensee provide a response to the Requested Actions within 90 days of the date of this bulletin. Enclosure 1 provides the responses to the Requested Actions.

There are no regulatory commitments contained in this letter.

Please address any comments or questions regarding this matter to Rick Abbott at 980-875-4685.

I declare under penalty of perjury that the foregoing is true and correct.

Respectfully,

Steven D. Capps

Enclosure 1:

IE76
HCR

U.S. Nuclear Regulatory Commission
October 25, 2012
Page 2

xc: with enclosure

V. M. McCree, Region II Administrator
U.S. Nuclear Regulatory Commission
Marquis One Tower
245 Peachtree Center Avenue NE,
Suite 1200
Atlanta, Georgia 30303-1257

E. J. Leeds
Director, Office of Nuclear Reactor Regulation
U.S. Nuclear Regulatory Commission
11555 Rockville Pike
Mail Stop 13-H16M
Rockville, MD 20852-2738

J. H. Thompson, Project Manager
U. S. Nuclear Regulatory Commission
11555 Rockville Pike
Mail Stop 0-8 G9A
Rockville, MD 20852-2738

John Zeiler
NRC Senior Resident Inspector
McGuire Nuclear Station

Enclosure 1

Bulletin 2012-01 Response

Overview:

- System Description - Items 2., 1.d, 2.a, 2.c
- System Protection - 1., 1.a, 2.b, 2.d
- Consequences - 1.b, 1.c, 2.e
- Attachment 2 - Unit 1 Simplified One-Line Diagram
- Attachment 2a - Unit 2 Simplified One-Line Diagram
- Attachment 3 - Tables
 - Table 1 - ESF Buses Continuously Powered From Offsite Power Source(s)
 - Table 2 - ESF Buses Not Continuously Powered From Offsite Power Source(s)
 - Table 3 - ESF Buses Major Loads
 - Table 4 - Offsite Power Transformers
 - Table 5 - Protective Devices

System Description

Items 2, 1.d, 2.a, and 2.c request system information and will be addressed in this section:

2. Briefly describe the operating configuration of the ESF buses (Class 1E for current operating plants or non-Class 1E for passive plants) at power (normal operating condition).

Response:

McGuire is connected to offsite power through parallel Main Step-Up (MSU) transformers and parallel Bus Lines (BL). Each of these transformers is connected to parallel Generator Circuit Breakers (GCB) which serves as the connection point of the main generator to offsite and onsite power system.

During normal loading conditions, the main generator supplies power to the ESF busses through the GCBs and various auxiliary transformers. McGuire Unit 1 connects to a 230 kV Switchyard, and McGuire Unit 2 connects to a 525 kV Switchyard.

Enclosure 1

Bulletin 2012-01 Response

Upon a reactor, turbine, or generator trip, the GCBs open which separates the main generator from the offsite and onsite power systems. By opening the GCBs, the parallel MSU transformers immediately provide offsite power to the ESF busses with no bus transfer schemes required.

See Attachment 2 and 2a, for simplified one-line diagrams of the Unit 1 and Unit 2 power system. Note Attachment 2 and 2a shows transformers 1ATE and 2ATE. These transformers supply power to the auxiliary electric boilers and do not supply power to any ESF loads.

1.d. Describe the offsite power transformer (e.g., start-up, reserve, station auxiliary) winding and grounding configurations.

Response:

See Attachment 3, Table 4 for offsite power transformer winding and grounding configurations.

2. a. Are the ESF buses powered by offsite power sources? If so, explain what major loads are connected to the buses including their ratings.

Response:

Yes, for normal operating condition configurations Emergency Safeguard Feature (ESF) buses and non-safety loads are aligned to offsite sources, but powered from the main generator.

See Attachment 3, Tables 1 and 2 for ESF bus power sources.

See Attachment 3, Table 3 for ESF bus major loads energized during normal power operations, including their ratings.

2.c. Confirm that the operating configuration of the ESF buses is consistent with the current licensing basis. Describe any changes in offsite power source alignment to the ESF buses from the original plant licensing.

Response:

The current licensing basis for McGuire Nuclear Station credits two independent offsite power sources that are capable of supplying power to two independent ESF busses. This confirms the operating configuration of the ESF buses is consistent with the current licensing basis. No changes from the original licensing basis have been made for offsite power alignments to the ESF busses.

Each nuclear generating unit is provided with two independent immediate access circuits of offsite power from the Transmission System. For Unit 1, each circuit consists of a connection from the 230 kV switching station over an independent 230 kV overhead transmission line through one of the two half-sized step-up transformers (1A, 1B) to one of the two unit auxiliary

Enclosure 1

Bulletin 2012-01 Response

transformers. For Unit 2, each circuit consists of a connection from the 525 kV Switching Station over an independent 525 kV overhead transmission line through one of the two half-sized step-up transformers (2A, 2B) to one of the two unit auxiliary transformers.

Each unit is provided with two full size auxiliary power transformers (1ATA, 1ATB, 2ATA, 2ATB) which are rated 60/80/100 MVA and are sized to carry all of the auxiliaries of one operating nuclear unit plus the safety shutdown loads of the other nuclear unit. Each auxiliary transformer has two secondary windings, with each winding normally energizing one 6900 Volt unit normal auxiliary switchgear assembly.

The 6900 Volt Normal Auxiliary Power System of each nuclear unit consists of four assemblies of auxiliary switchgear with each assembly connected through two main breakers and buses to the two unit auxiliary power transformers (1TA, 1TB, 1TC, 1TD, 2TA, 2TB, 2TC, 2TD). With the two full-sized power transformers available, only two of the four switchgear assemblies normally receive power from each auxiliary power transformer. The 6900 Volt Normal Auxiliary Power System furnishes power to all of the large station auxiliary loads such as the reactor coolant pumps, condenser circulating water pumps, hotwell pumps, etc.; in addition, the system normally furnishes power to the two redundant and independent 4160 Volt Essential Auxiliary Power Systems of each unit through 6900/4160 Volt transformers (1ATC, 1ATD, 2ATC, 2ATD, SATA, SATB).

In the event of the loss of one of the unit auxiliary transformers, the two 6900V switchgear assemblies that are normally energized from that transformer will automatically transfer to the alternate unit auxiliary transformer, which will then furnish power to the four switchgear assemblies.

Each unit has two redundant and independent 4160 Volt Essential Auxiliary Power Systems (1ETA, 1ETB, 2ETA, and 2ETB). All ESF loads are supplied power during a blackout or accident condition from the 4160 Volt Essential Auxiliary Power System. Each of the 4160 Volt Essential Auxiliary Power Systems is provided with a diesel-engine generator (DG) connected to automatically start and supply power in the event that power from the 6900 Volt bus is not available.

The following at power (normal operating condition) configurations have been confirmed to be consistent with the current licensing basis as described in Technical Specifications Bases 3.8.1 (AC Sources, Operating) (refer to Attachment 2 and 2a for a one-line diagram for the offsite power design):

Unit 1 A Train

1. BL1A-1ATA-1TA-1ATC-1ETA
2. BL1B-1ATB-1TA-1ATC-1ETA
3. BL1A-1ATA-1TC-SATA-1ETA
4. BL1B-1ATB-1TC-SATA-1ETA
5. BL2A-2ATA-2TC-SATA-1ETA
6. BL2B-2ATB-2TC-SATA-1ETA

Enclosure 1
Bulletin 2012-01 Response

Unit 1 B Train

1. BL1B-1ATB-1TD-1ATD-1ETB
2. BL1A-1ATA-1TD-1ATD-1ETB
3. BL1B-1ATB-1TB-SATB-1ETB
4. BL1A-1ATA-1TB-SATB-1ETB
5. BL2B-2ATB-2TB-SATB-1ETB
6. BL2A-2ATA-2TB-SATB-1ETB

Unit 2 A Train

1. BL2A-2ATA-2TA-2ATC-2ETA
2. BL2B-2ATB-2TA-2ATC-2ETA
3. BL2A-2ATA-2TC-SATA-2ETA
4. BL2B-2ATB-2TC-SATA-2ETA
5. BL1A-1ATA-1TC-SATA-2ETA
6. BL1B-1ATB-1TC-SATA-2ETA

Unit 2 B Train

1. BL2B-2ATB-2TD-2ATD-2ETB
2. BL2A-2ATA-2TD-2ATD-2ETB
3. BL2B-2ATB-2TB-SATB-2ETB
4. BL2A-2ATA-2TB-SATB-2ETB
5. BL1B-1ATB-1TB-SATB-2ETB
6. BL1A-1ATA-1TB-SATB-2ETB

Enclosure 1

Bulletin 2012-01 Response

System Protection

Items 1, 1.a, 2.b, and 2.d request information regarding electrical system protection and will be addressed in this section:

1. Given the requirements above, describe how the protection scheme for ESF buses (Class 1E for current operating plants or non-Class 1E for passive plants) is designed to detect and automatically respond to a single-phase open circuit condition or high impedance ground fault condition on a credited off-site power circuit or another power sources. Also, include the following information:

Response:

Consistent with the current licensing basis and GDC 17, existing protective circuitry will separate the ESF buses from a connected failed offsite source due to a loss of voltage or a sustained, balanced degraded grid voltage concurrent with certain design basis accidents. The relay systems were not specifically designed to detect an open single phase of a three phase system.

Each of the redundant 4160 Volt Essential Auxiliary Power System buses is provided with two levels of undervoltage protection to monitor bus voltage. Each level is provided with a separate set of three undervoltage relays which are utilized in a two-out-of-three logic scheme.

The first level of undervoltage relays detects a loss of voltage condition on the 4160 Volt Essential Auxiliary Power System bus. The loss of voltage relays drop out at approximately 76% voltage. The loss of voltage setpoint was selected such that relay operation will not be initiated during normal power transients. If two-out-of-three relays detect a loss of voltage condition, the 4160 Volt Essential Auxiliary Power System bus will be separated from offsite power.

The second level of undervoltage relays detects a degraded voltage condition on the 4160 Volt Essential Auxiliary Power System bus. The degraded voltage relays drop out at approximately 88% voltage for Unit 1 and approximately 89% voltage for Unit 2. This second level of protection employs two time delays. If two-out-of-three relays on a bus detect a degraded voltage condition, the two timing relays are started. One timing relay, set at less than or equal to 11 seconds, ensures that the degraded voltage condition is not a short-duration transient. If the degraded voltage persists until after this relay has completed its timing cycle, an annunciator alarm is activated in the control room. The second timing relay, set at less than or equal to 600 seconds, continues its timing cycle to allow a period in which the operators can implement actions to correct the degraded voltage condition. If the degraded voltage condition remains present until the completion of the second timing cycle, the 4160 Volt Essential Auxiliary Power System bus will be separated from offsite power. In addition, at any time after the first timing cycle and before the end of the second timing cycle, separation of the 4160 Volt Essential Auxiliary Power System bus from offsite power will occur automatically in the event of a safety injection (SI) actuation signal during degraded voltage conditions.

During normal plant operation, offsite power is aligned to the essential buses through Main Step-Up Transformers (MSUs), Unit Auxiliary Transformers (UATs), and Auxiliary Power

Enclosure 1

Bulletin 2012-01 Response

Transformers. An open phase on the primary-side of the MSU Transformer would have no direct effect on essential bus voltage with the unit on-line since the main generator feeds three phase power to the secondary-side of the MSUs through the UATs and onto the essential buses (reference Attachment 2 and 2a). If the main generator trips from such a condition (possibly due to high negative sequencing currents), power may be lost to the essential bus(es) thus actuating the protective relaying at the essential bus(es).

Response of the essential buses, or the response of the main generator to such a condition, was not specifically analyzed for an open MSU phase. As stated above, even in the presence of such a condition, if voltage at the essential buses degrade to the point of detection by the protective relaying circuitry, the essential buses will be isolated from offsite power (reference Request 1.a, below, for further detail).

High impedance ground faults were not specifically analyzed on offsite power circuits. However, similar to the response from the previous paragraph, if a high impedance fault on an offsite power circuit is such that it affects the essential buses, the protective relaying will respond by isolating the offsite power circuit. This level of coordination ensures equipment supplied by the essential buses are not impaired or operated outside of their designed ratings.

1.a. The sensitivity of protective devices to detect abnormal operating conditions and the basis for the protective device setpoint(s).

Response:

Consistent with the current licensing basis and GDC 17, existing electrical protective devices are sufficiently sensitive to detect design basis conditions like a loss of voltage or a degraded voltage, but were not designed to detect a single phase open circuit condition. See Attachment 3, Table 5 for undervoltage protective devices and the basis for the device setpoint(s).

Existing electrical protective devices are also sufficiently sensitive to detect a ground fault. Attachment 3, Table 5 lists ground protection/alarms on the ESF buses and the basis for the device setpoint(s).

2.b. If the ESF buses are not powered by offsite power sources, explain how the surveillance tests are performed to verify that a single-phase open circuit condition or high impedance ground fault condition on an off-site power circuit is detected.

Response:

The essential buses at McGuire are aligned to offsite power sources during normal operation, but are powered by the main generator.

Technical Specification Section 3.8 requires two OPERABLE circuits between the offsite transmission system and the onsite essential power system during Modes 1 through 4 and one OPERABLE circuit during Modes 5, 6, and during irradiated fuel movement. Surveillance procedures verify proper breaker alignment from the Switchyard to the essential buses, and

Enclosure 1

Bulletin 2012-01 Response

verification of voltage from the 24 kV, the 6.9 kV, and the 4.16 kV levels. This surveillance is performed weekly. An additional surveillance is performed when verifying remaining operable power sources if an offsite power source or D/G becomes inoperable.

2.d. Do the plant operating procedures, including off-normal operating procedures, specifically call for verification of the voltages on all three phases of the ESF buses

Response:

At the 4.16 kV level, metering for the secondary-side of the 6.9/4.16 kV Transformers includes a voltmeter and a voltage transducer. Though this voltage is not monitored on all three phases, provisions are included at the 4.16 kV buses with a switched voltmeter to monitor all three phases. The current plant surveillance procedures record this voltage on a weekly basis and when verifying remaining operable power sources if an offsite power source or D/G becomes inoperable. However, voltage from only a single phase is verified and recorded.

Consequences

Items 1.b, 1.c, and 2.e request information regarding the electrical consequences of an event and will be addressed in this section:

1.b. The differences (if any) of the consequences of a loaded (i.e., ESF bus normally aligned to offsite power transformer) or unloaded (e.g., ESF buses normally aligned to unit auxiliary transformer) power source.

Response:

Installed relays were not designed to detect single phase open circuit conditions. Existing loss of voltage and degraded voltage relays may respond depending on load and possible grounds. In general, there will be no plant response for an unloaded power source in the event of a single-phase open circuit on a credited off-site power circuit because there is insufficient current to detect a single-phase open circuit for this configuration.

The plant response for a loaded power source cannot be calculated without specifying the amount of loading and the specific loads involved.

Enclosure 1

Bulletin 2012-01 Response

1.c. If the design does not detect and automatically respond to a single-phase open circuit condition or high impedance ground fault condition on a credited offsite power circuit or another power sources, describe the consequences of such an event and the plant response.

Response:

A high impedance ground will have no immediate effect on plant operation. If the ground is sufficiently large to affect plant operation, protective relaying will isolate the ground automatically.

McGuire Nuclear Station did not describe in the Current Licensing Basis (CLB) that the Class 1E protection scheme (for the emergency safeguard feature (ESF) buses) was designed to detect and automatically respond to a single-phase open circuit condition and therefore was not described in the UFSAR or Technical Specifications.

Since McGuire Nuclear Station did not credit the ESF bus protection scheme as being capable of detecting and automatically responding to a single phase open circuit condition, an open phase fault was not included in the design criteria for either the loss of voltage, the degraded voltage relay (DVR) scheme or secondary level undervoltage protection system (SLUPS) design criteria. Since open phase detection was not credited in the McGuire Nuclear Station design or licensing basis, no design basis calculations or design documents exist that previously considered this condition. Detailed plant specific models would need to be developed (e.g., transformer magnetic circuit models, electric distribution models, motor models; including positive, negative, and zero sequence impedances (voltage and currents), and the models would need to be compiled and analyzed for the McGuire Nuclear Station specific Class 1E electric distribution system (EDS)).

2.e. If a common or single offsite circuit is used to supply redundant ESF buses, explain why a failure, such as a single-phase open circuit or high impedance ground fault condition, would not adversely affect redundant ESF buses.

Response:

Not applicable since McGuire Nuclear Station does not use a common or single offsite circuit to supply redundant ESF busses.

Enclosure Bulletin 2012-01

Attachment 2
Unit 1 Simplified One-Line Diagram

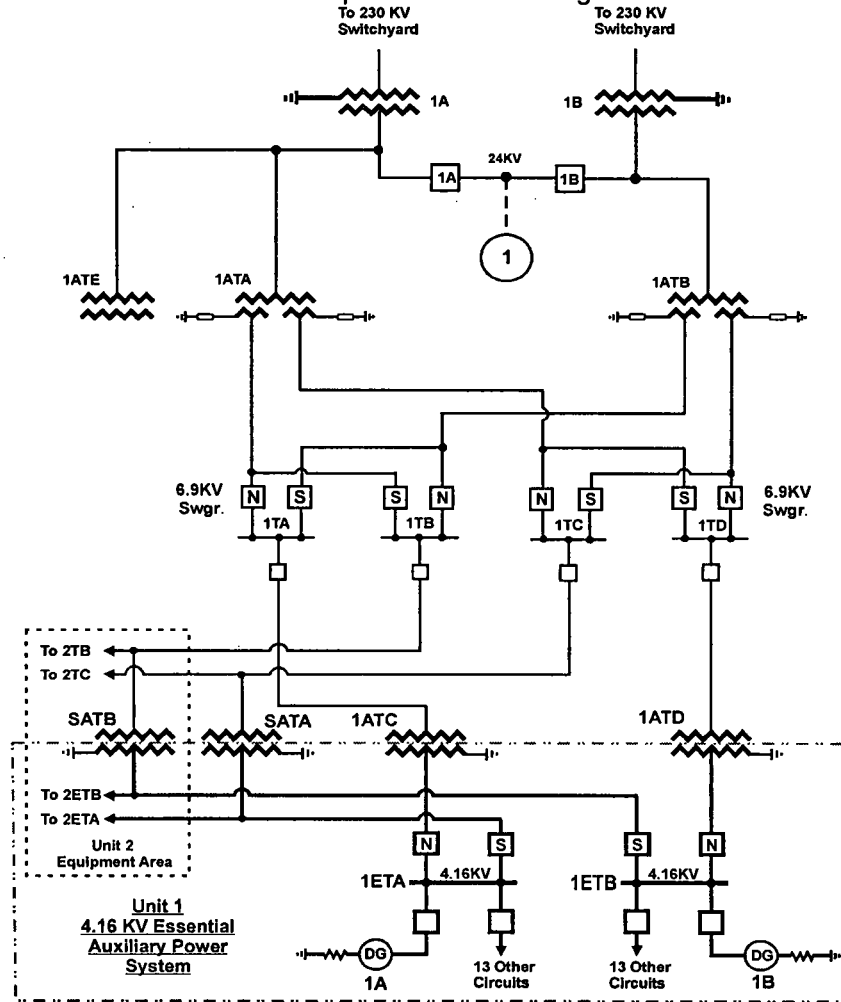

Enclosure Bulletin 2012-01

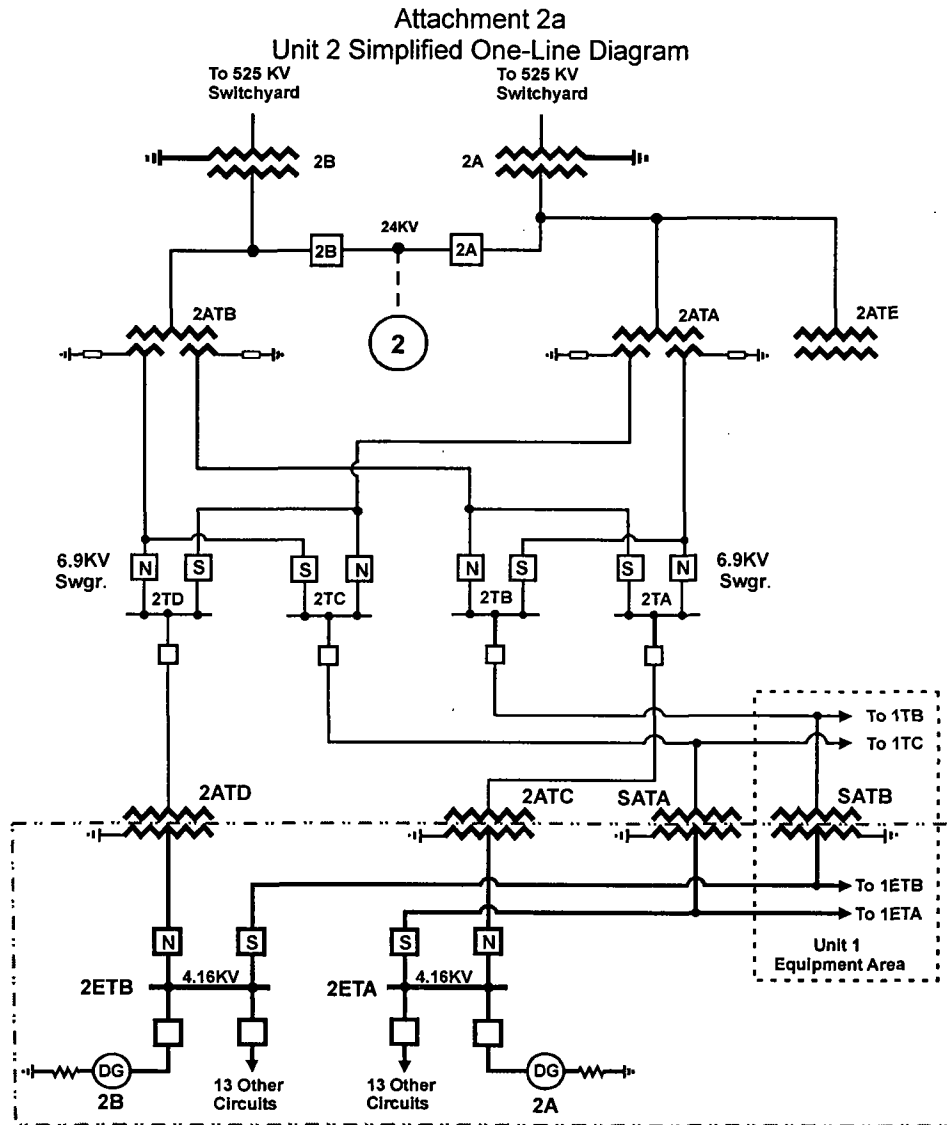

Enclosure Bulletin 2012-01

Attachment 3 - Tables McGuire Nuclear Station

Table 1 - ESF Buses Continuously Powered From Offsite Power Source(s)

Description of ESF Bus Power Source	ESF Bus Name (normal operating condition).	Original licensing basis configuration (Y/N)
Busline 1A	1ETA	Y
Busline 1B	1ETB	Y
Busline 2A	2ETA	Y
Busline 2B	2ETB	Y

Table 2 - ESF Buses Not Continuously Powered From Offsite Power Source(s)

Description of ESF Bus Power Source	ESF Bus Name (normal operating condition).	Original licensing basis configuration (Y/N)
Note: Table 2 is not applicable to the McGuire Nuclear Station		

Table 3 - ESF Buses Normally Energized Major Loads

ESF Bus	Load	Voltage Level (V)	Rating (HP)
1ETA	Nuclear Service Water Pump 1A	4160	1000
1ETA	Component Cooling Water Pump 1A1	4160	200
1ETA	Component Cooling Water Pump 1A2	4160	200
1ETA	Centrifugal Charging Pump 1A	4160	600
1ETA	Fuel Pool Cooling Pump 1A	4160	200
1ETA	Control Area Ventilation System A*	4160	495
1ETB	Nuclear Service Water Pump 1B	4160	1000
1ETB	Component Cooling Water Pump 1B1	4160	200
1ETB	Component Cooling Water Pump 1B2	4160	200
1ETB	Centrifugal Charging Pump 1B	4160	600
1ETB	Fuel Pool Cooling Pump 1B	4160	200
1ETB	Control Area Ventilation System B*	4160	495
	*Shared Between Units		

Enclosure Bulletin 2012-01

Table 3 (continued)

ESF Bus	Load	Voltage Level (V)	Rating (HP)
2ETA	Nuclear Service Water Pump 2A	4160	1000
2ETA	Component Cooling Water Pump 2A1	4160	200
2ETA	Component Cooling Water Pump 2A2	4160	200
2ETA	Centrifugal Charging Pump 2A	4160	600
2ETA	Fuel Pool Cooling Pump 2A	4160	200
2ETA	Control Area Ventilation System A*	4160	495
2ETB	Nuclear Service Water Pump 2B	4160	1000
2ETB	Component Cooling Water Pump 2B1	4160	200
2ETB	Component Cooling Water Pump 2B2	4160	200
2ETB	Centrifugal Charging Pump 2B	4160	600
2ETB	Fuel Pool Cooling Pump 2B	4160	200
2ETB	Control Area Ventilation System B*	4160	495
	*Shared Between Units		

Enclosure Bulletin 2012-01

Table 4 - Offsite Power Transformers

Transformer	Winding Configuration	MVA Size (AO/FA/FOA)	Voltage Rating (Primary/Secondary)	Grounding Configuration
<i>MSU 1A and 1B</i>	<i>Wye-Delta</i>	<i>760 MVA FOA</i>	<i>230/22.8 kV</i>	<i>Neutral Solidly Grounded</i>
<i>MSU 2A and 2B</i>	<i>Wye-Delta</i>	<i>750 MVA FOA</i>	<i>525/22.8 kV</i>	<i>Neutral Solidly Grounded</i>
<i>1ATA, 1ATB, 2ATA, 2ATB</i>	<i>Delta-Wye/Wye (Three Winding)</i>	<i>60/80/100 MVA</i>	<i>22.8/6.9 kV</i>	<i>Neutral Resistively Grounded</i>
<i>1ATC, 1ATD, 2ATC, 2ATD, SATA, SATB</i>	<i>Delta-Wye</i>	<i>5.5 MVA (Air Cooled)</i>	<i>6.9/4.16 kV</i>	<i>Neutral Solidly Grounded</i>

Enclosure Bulletin 2012-01

Table 5 - Protective Devices

Protection Zone	Protective Device	UV Logic	Setpoint (Nominal)	Basis for Setpoint
4 KV ESF Bus	Loss of Voltage Relay	2 of 3	Unit 1: 3174.5 (76.3%) Unit 2: 3157 (75.9%)	To actuate upon complete loss of ESF Bus voltage condition
4 KV ESF Bus	Degraded Grid	2 of 3	Unit 1: 3689 (88.7%) Unit 2: 3713.5 (89.3%)	To actuate upon sustained degraded ESF Bus voltage condition
4 kV ESF Bus	Motor and Transformer Ground Protection (50G)	NA	5 Amps Zero Sequence Current, 0.1 second delay	To provide sensitive monitoring for ground faults on ESF loads. This protection trips the load's breaker during all modes of operation including emergency scenarios.
4 kV ESF Bus	Normal and Standby Feeder Breaker Ground Protection (51G)	NA	120 Amps Zero Sequence Current, 0.4 second delay @ 500% of tap	To provide backup protection to sustained ground faults on the ESF bus or loads. The pickup and time delay settings were chosen to provide sufficient coordination with 50G relays. This protective device trips the ESF bus incoming breaker during all modes of operation including emergency scenarios.
4 kV Emergency Diesel Generator	Neutral Ground Overvoltage (59DGN)	NA	5 Volts on secondary of neutral grounding transformer, 2 second delay	The emergency diesel generator is resistively grounded through a neutral grounding transformer. This protective device provides backup protection to sustained ground faults on the ESF bus, loads, or generator while it is supplying power to the ESF bus. The pickup and time delay settings were chosen to provide sufficient coordination with 50G relays. This protective device trips the diesel breaker during non-emergency scenarios. The relay provides an alarm-only function during emergency scenarios and does not provide a trip signal to the diesel breaker.