

August 14, 2006

Mr. Robert A. Wharton
Vice President for Academic Affairs
Idaho State University
Campus Box 8063
Pocatello, ID 83209-8063

SUBJECT: ISSUANCE OF AMENDMENT NO. 6 TO FACILITY OPERATING LICENSE NO.
R-110 - IDAHO STATE UNIVERSITY AGN-201M RESEARCH REACTOR
(TAC NO. MB6757)

Dear Mr. Wharton:

The U.S. Nuclear Regulatory Commission has issued Amendment No. 6 to Facility Operating License No. R-110 for the Idaho State University AGN-201M Research Reactor in response to the application for renewal dated November 21, 1995, as supplemented on January 31, 2003 and July 10, 2003. This amendment renews the operating license for 20 years from its date of issuance.

In accordance with our practice, we have restated the license in its entirety, incorporating all the changes and amendments made since issuance of the original license.

Enclosed with the amended license is a copy of the Notice of Renewal that is being sent to the Office of the Federal Register for publication, and the Safety Evaluation Report associated with the renewal. The Environmental Assessment was sent to you under separate cover. If you have any questions, please contact me at 301-415-1631.

Sincerely,

/RA/

Daniel E. Hughes, Project Manager
Research and Test Reactors Branch
Division of Policy and Rulemaking
Office of Nuclear Reactor Regulation

Docket No. 50-284

Enclosures: 1. Amendment No. 6
2. Safety Evaluation Report
3. Notice of Renewal

cc w/enclosures: See next page

August 14, 2006

Mr. Robert A. Wharton
Vice President for Academic Affairs
Idaho State University
Campus Box 8063
Pocatello, ID 83209-8063

SUBJECT: ISSUANCE OF AMENDMENT NO. 6 TO FACILITY OPERATING LICENSE NO.
R-110 - IDAHO STATE UNIVERSITY AGN-201M RESEARCH REACTOR
(TAC NO. MB6757)

Dear Mr. Wharton:

The U.S. Nuclear Regulatory Commission has issued Amendment No. 6 to Facility Operating License No. R-110 for the Idaho State University AGN-201M Research Reactor in response to the application for renewal dated November 21, 1995, as supplemented on January 31, 2003 and July 10, 2003. This amendment renews the operating license for 20 years from its date of issuance.

In accordance with our practice, we have restated the license in its entirety, incorporating all the changes and amendments made since issuance of the original license.

Enclosed with the amended license is a copy of the Notice of Renewal that is being sent to the Office of the Federal Register for publication, and the Safety Evaluation Report associated with the renewal. The Environmental Assessment was sent to you under separate cover. If you have any questions, please contact me at 301-415-1631.

Sincerely,

/RA/

Daniel E. Hughes, Project Manager
Research and Test Reactors Branch
Division of Policy and Rulemaking
Office of Nuclear Reactor Regulation

Docket No. 50-284

Enclosures: 1. Amendment No. 6
2. Safety Evaluation Report
3. Notice of Renewal

cc w/enclosures: See next page

DISTRIBUTION:

PUBLIC PRTA/B r/f OGC EHylton BThomas HNieh
CGrimes GHolahan GHill (2)

ACCESSION NO.: ML060610619

TEMPLATE #: NRR-058

OFFICE	PRT:CE	PRT:LA	PRT:PM	OGC	PRT:BC
NAME	PDoyle*	Ehylton:tls*	DHughes*	SUttal*	BThomas:tls*
DATE	05/19/2006	06/01/2006	8/4/2006	7/25/2006	8/14/2006

OFFICIAL RECORD COPY

Idaho State University

Docket No. 50-284

cc:

Idaho State University
ATTN: Dr. John Bennion
Reactor Supervisor
Pocatello, ID 83209

Idaho State University
ATTN: Mr. Tom Gesell
Radiation Safety Officer
Physics Department
Box 8106
Pocatello, ID 83209

Radiation Control Program Director
Division of Environment
450 West State, 3rd Floor
Boise, ID 83720

Test, Research and Training
Reactor Newsletter
202 Nuclear Sciences Center
University of Florida
Gainesville, FL 32611

UNITED STATES NUCLEAR REGULATORY COMMISSION

DOCKET NO. 50-284

IDAHO STATE UNIVERSITY

RENEWAL OF THE FACILITY OPERATING LICENSE

Amendment No. 6
License No. R-110

1. The U.S. Nuclear Regulatory Commission (the Commission) has found that:
 - A. The application for amendment for renewal filed by the Idaho State University (the license) dated November 21, 1995, as supplemented on January 31, 2003 and July 10, 2003, complies with the standards and requirements of the Atomic Energy Act of 1954, as amended (the Act), and the Commission's rules and regulations set forth in Title 10, Chapter I, Code of Federal Regulations (10 CFR).
 - B. The facility will operate in conformity with the application, the provisions of the Act, and the rules and regulations of the Commission;
 - C. There is reasonable assurance that (i) that the activities authorized by this amendment can be conducted without endangering the health and safety of the public and (ii) that such activities will be conducted in compliance with the Commission's regulations;
 - D. The licensee is technically and financially qualified to engage in the activities authorized by this operating license in accordance with the rules and regulations of the Commission;
 - E. The licensee has satisfied the applicable provisions of 10 CFR Part 140, "Financial Protection Requirements and Indemnity Agreements," of the Commission's regulations;
 - F. The issuance of this license will not be inimical to the common defense and security or to the health and safety of the public;
 - G. The issuance of this license is in accordance with 10 CFR Part 51 of the Commission's regulations and all applicable requirements have been satisfied; and
 - H. The receipt, possession and use of the byproduct and special nuclear materials as authorized by this license will be in accordance with the Commission's regulations in 10 CFR Parts 30, 40, and 70, including Sections 30.33, 70.23 and 70.31.

2. Facility Operating License No. R-110 is hereby amended in its entirety to read as follows:
 - A. This license applies to the AGN-201M research reactor (herein "the reactor"), owned by the Idaho State University and located on its campus in Pocatello, Idaho, and is described in the application for license dated November 21, 1995, and supplements dated January 31, 2003 and July 10, 2003, (renewal herein referred to as "the application"), and authorized for operation of License No. R-110.
 - B. Subject to the conditions and requirements incorporated herein, the Commission hereby licenses the Idaho State University:
 1. Pursuant to Section 104c of the Act and 10 CFR Part 50, "Domestic Licensing of Production and Utilization Facilities," to possess, use and operate the reactor as a utilization facility in accordance with the procedures and limitations described in the application and in this licensee;
 2. Pursuant to the Act and 10 CFR Part 70, "Domestic Licensing of Special Nuclear Material," to receive, possess and use up to 995 grams of contained uranium-235, enriched to 20% in uranium dioxide (UO₂) embedded in radiation stabilized polyethylene, in connection with the operation of the reactor; and
 3. Pursuant to the Act and 10 CFR Part 30, "Rules of General Applicability to Domestic Licensing of Byproduct Material," to possess, but not to separate, such byproduct material as may be produced by the operation of the reactor.
 - C. This license shall be deemed to contain and be subject to the conditions specified in Parts 20, 30, 40, 50, 51, 55, 70, and 73 of 10 CFR Chapter I, to all applicable provisions of the Act, and to the rules, regulations and orders of the Commission now, or hereafter in effect, and to the additional conditions specified below:
 1. Maximum Power Level

The licensee is authorized to operate the reactor at steady-state power levels up to a maximum of 5 watts (thermal).
 2. Technical Specification

The Technical Specifications contained in Appendix A, as revised through Amendment No. 6, are hereby incorporated in the license. The licensee shall operate the facility in accordance with the Technical Specifications. No changes shall be made in the Technical Specifications unless authorized by the Commission as provided in Section 50.59 of 10 CFR Part 50.

3. Physical Security Plan

The licensee shall maintain and fully implement all provisions of the Commission's approved physical security plan, including amendments and changes made pursuant to the authority of 10 CFR 50.54(p). The approved physical security plan consists of the "Physical Security Plan for Lillibridge Engineering Lab Idaho State University," Revision 4, dated November 22, 1995, withheld from public disclosure pursuant to 10 CFR 2.390(d), submitted by letter dated January 31, 2003, under License R-110.

4. Reactor Operator Requalification Plan

Revision 3 to the Reactor Operator Requalification Plan as submitted by the facility staff on July 10, 2005, as part of the license renewal is hereby approved by the NRC. The licensee shall operate the facility in accordance with the Reactor Operator Requalification Plan. No changes shall be made in the Reactor Operator Requalification Plan unless authorized by the Commission as provided in Section 55.59 of 10 CFR Part 55.

5. Emergency Plan

Revision 6 to the Emergency Plan as submitted by the facility staff as part of their license renewal, and updated July 10, 2005, is hereby approved by the NRC. The licensee shall operate the facility in accordance with the Emergency Plan. No changes shall be made in the Emergency Plan unless authorized by the Commission as provided in Section 50.54(r) of 10 CFR Part 50.

3. This license is effective as of the date of its issuance and shall expire 20 years from its date of issuance.

FOR THE NUCLEAR REGULATORY COMMISSION

/RA/

Brian E. Thomas, Chief
Research and Test Reactors Branch
Division of Policy and Rulemaking
Office of Nuclear Reactor Regulation

Enclosures: Appendix A, Technical Specifications

Date of Issuance: August 14, 2006

APPENDIX A
TO FACILITY OPERATING
LICENSE NO. R-110
TECHNICAL SPECIFICATIONS
FOR
IDAHO STATE UNIVERSITY AGN-201 M REACTOR (SERIAL NO. 103)
DOCKET NO. 50-284

TABLE OF CONTENTS

	<u>PAGE</u>
1.0 <u>DEFINITIONS</u>	- 2 -
2.0 <u>SAFETY LIMITS AND LIMITING SAFETY SYSTEM SETTINGS</u>	- 6 -
2.1 <u>Safety Limits</u>	- 6 -
2.2 <u>Limiting Safety System Settings (LSSS)</u>	- 6 -
3.0 <u>LIMITING CONDITIONS FOR OPERATION</u>	- 8 -
3.1 <u>Reactivity Limits</u>	- 8 -
3.2 <u>Control and Safety Systems</u>	- 8 -
3.3 <u>Limitations on Experiments</u>	- 11 -
3.4 <u>Radiation Monitoring, Control and Shielding</u>	- 12 -
4.0 <u>SURVEILLANCE REQUIREMENTS</u>	- 14 -
4.1 <u>Reactivity Limits</u>	- 14 -
4.2 <u>Control and Safety System</u>	- 14 -
4.3 <u>Reactor Structure</u>	- 15 -
4.4 <u>Radiation Monitoring and Control</u>	- 16 -
5.0 <u>DESIGN FEATURES</u>	- 18 -
5.1 <u>Reactor</u>	- 18 -
5.2 <u>Fuel Storage</u>	- 18 -
5.3 <u>Reactor Room</u>	- 19 -
6.0 <u>ADMINISTRATIVE CONTROLS</u>	- 20 -
6.1 <u>Organization</u>	- 20 -
6.2 <u>Staff Qualifications</u>	- 23 -
6.3 <u>Training</u>	- 23 -
6.4 <u>Reactor Safety Committee</u>	- 23 -
6.5 <u>Approvals</u>	- 25 -
6.6 <u>Procedures</u>	- 25 -
6.7 <u>Experiments</u>	- 26 -
6.8 <u>Safety Limit Violation</u>	- 26 -
6.9 <u>Reporting Requirements</u>	- 26 -
6.10 <u>Record Retention</u>	- 29 -

1.0 DEFINITIONS

The terms Safety Limit (SL), Limiting Safety System Setting (LSSS), and Limiting Conditions for Operation (LCO) are as defined in 10 CFR 50.36

- 1.1 Authorized Operators – An authorized operator is an individual authorized by the Reactor Supervisor to operate the reactor controls and who does so with the knowledge of the Reactor Supervisor and under the direct supervision of a Reactor Operator.
- 1.2 Certified Observers – A certified observer is an individual certified by the Reactor Supervisor as qualified to activate manual scram and initiate emergency procedures.
- 1.3 Channel Calibration – A channel calibration is an adjustment of the channel such that its output responds, within acceptable range and accuracy, to known values of the parameter which the channel measures. Calibration shall encompass the entire channel, including equipment, actuation, alarm, or trip.
- 1.4 Channel Check – A channel check is a qualitative verification of acceptable performance by observation of channel behavior. This verification may include comparison of the channel with other independent channels or methods measuring the same variable.
- 1.5 Channel Test – A channel test is the introduction of a signal into the channel to verify that it is operable.
- 1.6 Coarse Control Rod – The scrammable control rod that can be mechanically withdrawn/inserted at two possible speeds (25 to 53 seconds full insertion time or 75 to 125 seconds full insertion time).
- 1.7 Control Rod – Any of the four moveable rods loaded with fuel that are manipulated by the reactor operator to change the reactivity of the reactor.
- 1.8 Excess Reactivity – The amount of reactivity above critical ($k_{\text{eff}} = 1$). The excess reactivity is the amount of reactivity that would exist if all control rods were moved to their maximum reactive positions from the point where the reactor is exactly critical.
- 1.9 Experiment –
 - a. An experiment is any of the following:
 - (1) An activity utilizing the reactor system or its components of the neutrons or radiation generated therein;
 - (2) An evaluation or test of a reactor system operational, surveillance, or maintenance technique; or
 - (3) The material content of any of the foregoing, including structural components, encapsulation or confining boundaries, and contained fluids or solids.

- b. Secured Experiment – Any experiment, or component of an experiment is deemed to be secured, or in a secured position, if it is held in a stationary position relative to the reactor by mechanical means. The restraint shall exert sufficient force on the experiment to overcome the expected effects of hydraulic, pneumatic, buoyant, or other forces which are normal to the operating environment of the experiment or which might arise as a result of credible malfunctions.
 - c. Unsecured Experiment – Any experiment, or component of an experiment is deemed to be unsecured whenever it is not secured as defined in 1.9.b above. Moving parts of experiments are deemed to be unsecured when they are in motion.
 - d. Movable Experiment – A movable experiment is one which may be inserted, removed or manipulated while the reactor is critical.
 - e. Removable Experiment – A removable experiment is any experiment, experimental facility, or component of an experiment, other than a permanently attached appurtenance to the reactor system, which can reasonably be anticipated to be moved from one or more times during the life of the reactor.
- 1.10 Experimental Facilities – experimental facilities are those portions of the reactor assembly that are used for the introduction of experiments into or adjacent to the reactor core region or allow beams of radiation to exit from the reactor shielding. Experimental facilities shall include the thermal column, glory hole, and access ports.
- 1.11 Explosive Material – Explosive material is any solid or liquid which is categorized as a Severe, Dangerous, or Very Dangerous Explosion Hazard in Dangerous Properties of Industrial Materials, by N.I. Sax, 7th ed., (1989), or is given an Identification of Reactivity (Stability) Index of 2, 3, or 4 by the National Fire Protection Association in its publication 704-M, 1996, Identification System for Fire Hazards of Materials, also enumerated in the Handbook for Laboratory Safety, 2nd ed. (1971) published by the Chemical Rubber Company.
- 1.12 Fine Control Rod – A low worth, non-scrammable control rod used primarily to maintain an intended power level. Its position may be varied manually.
- 1.13 Measured Value – The measured value is the value of a parameter as it appears on the output of a channel.
- 1.14 Measuring Channel – A measuring channel is the combination of sensor, lines, amplifiers, and output devices which are connected for the purpose of measuring or responding to the value of a process variable.
- 1.15 Operable – Operable means a component or system is capable of performing its intended function in its normal manner.
- 1.16 Operating – Operating means a component or system is performing its intended function in its normal manner.
- 1.17 Potential Reactivity Worth – The potential reactivity worth of an experiment is the maximum absolute value of the reactivity change that would occur as a result of intended or anticipated changes or credible malfunctions that alter experiment position or configuration.

Evaluations of potential reactivity worth of experiments also shall include effects of possible trajectories of the experiment in motion relative to the reactor, its orientation along each trajectory, and circumstances which can cause internal changes such as creating or filling of void spaces or motion of mechanical components. For removable experiments, the potential reactivity worth is equal to or greater than the static reactivity worth.

1.18 Reactor Component – A reactor component is any apparatus, device, or material that is a normal part of the reactor assembly.

1.19 Reactor Operation – Reactor operation is any condition wherein the reactor is not shutdown.

1.20 Reactor Safety System –

1.21 Reactor Secured – The reactor is secured when:

- a. Either: (1) All safety and control rods are fully withdrawn from the core, or
(2) The core fuse melts resulting in separation of the core,

and:

- b. The reactor console key switch is in the “off” position and the key is removed from the console and under the control of a licensed operator.
- c. No work is in progress involving core fuel, core structure, installed control rods, or control rod drives unless they are physically decoupled from the control rods, and
- d. No experiments are being moved or serviced that have, on movement, a reactivity worth exceeding the maximum allowed for a single experiment, or one dollar, whichever is smaller.

1.22 Reactor Shutdown – The reactor is shutdown if it is subcritical by at least one dollar in reactivity in the reference condition with the reactivity worth of all experiments included. The reactor shall be considered shutdown whenever:

- A. Either: (1) All safety and control rods are fully withdrawn from the core, or
(2) The core fuse melts resulting in separation of the core,

and:

- b. The reactor console key switch is in the “off” position and the key is removed from the console and under the control of a licensed operator.

1.23 Restricted Area – A restricted area is an area in which access to personnel is controlled for the purpose of protecting individuals against undue risks from exposure to radiation and radioactive materials.

1.24 Safety Channel – A safety channel is a measuring channel in the reactor safety system.

1.25 Safety Control Rod – One of two scrammable control rods that can be mechanically

withdrawn/inserted at only one speed (25 to 55 seconds full insertion time).

- 1.26 Scram Time – The time for the control rods to change the reactor from a critical to a subcritical condition. In most cases, this time is less than or equal to the time it takes for the rod to fall from a full-in to full-out position.
- 1.27 Shall, Should and May – The word “shall” is used to denote a requirement; the word “should” is used to denote a recommendation; and the word “may” is used to denote permission — neither a requirement nor a recommendation.
- 1.28 Shutdown Margin – Shutdown margin shall mean the minimum shutdown reactivity necessary to provide confidence that the reactor can be made subcritical by means of the control and safety systems starting from any permissible operating condition assuming that the most reactive scrammable rod and the Fine Control Rod remain in their most reactive positions, and that the reactor will remain subcritical without any further operator action.
- 1.29 Static Reactivity Worth of Experiments – The static reactivity worth of an experiment is the value of the reactivity change which is measurable by calibrated control or regulating rod comparison methods between two defined terminal positions or configurations of the experiment. For removable experiments, the terminal positions are fully removed from the reactor and fully inserted or installed in the normal functioning or intended position.
- 1.30 Surveillance Time – A surveillance time indicates the frequency of tests to demonstrate performance. Allowable surveillance intervals shall not exceed the following:
 - a. Two-year - interval not to exceed 30 months.
 - b. Annual - interval not to exceed 15 months.
 - c. Semiannual - interval not to exceed seven and one-half months (30 weeks).
 - d. Quarterly - interval not to exceed four months.
 - e. Monthly - interval not to exceed six weeks.
- 1.31 True Value – The true value is the actual value for a parameter.
- 1.32 Unscheduled Shutdown – An unscheduled shutdown is defined as any unplanned shutdown of the reactor caused by actuation of the reactor safety system, operator error, equipment malfunction, or a manual shutdown in response to conditions that could adversely affect safe operation, not including shutdowns that occur during testing or check-out procedures.

2.0 SAFETY LIMITS AND LIMITING SAFETY SYSTEM SETTINGS

2.1 Safety Limits

Applicability

This specification applies to the maximum safe steady-state power level and maximum core temperature during steady-state or transient operation.

Objective

To assure that the integrity of the fuel material is maintained and all fission products are retained in the core matrix.

Specification

- a. The reactor power level shall not exceed 100 watts.
- b. The maximum core temperature shall not exceed 200°C during either steady-state or transient operation.

Basis

The polyethylene core material does not melt below 200°C and is expected to maintain its integrity and retain essentially all of the fission products at temperatures below 200°C. The Hazards Summary Report dated February, 1962 submitted on Docket F-15 by Aerojet-General Nucleonics (AGN) calculated a steady-state core average temperature rise of 0.44°C/watt. Therefore, a steady-state power level of 100 watts would result in an average core temperature rise of 44°C. The corresponding maximum core temperature would be below 200°C, thus assuring integrity of the core and retention of fission products.

2.2 Limiting Safety System Settings (LSSS)

Applicability

This specification applies to the parts of the reactor safety system which will limit maximum power and core temperature.

Objective

To assure that automatic protective action is initiated to prevent a safety limit from being exceeded.

Specification

- a. The safety channels shall initiate a reactor scram at the following limiting safety system settings:

<u>Channel</u>	<u>Condition</u>	LSSS
Nuclear Safety Channel No. 2	High Power	6 watts
Nuclear Safety Channel No. 3	High Power	6 watts

- b. The core thermal fuse shall melt when heated to a temperature of about 120°C resulting in core separation and reactivity loss greater than 5% $\Delta k/k$.

Basis

Based on instrumentation response times and scram tests, the AGN Hazards Report concluded that reactor periods in excess of 30-50 milliseconds would be adequately arrested by the scram system. Since the maximum available excess reactivity in the reactor is less than one dollar, the cannot become prompt critical and the corresponding shortest possible period is greater than 200 milliseconds. The high power LSSS of 6 watts in conjunction with automatic safety systems and/or manual scram capabilities will assure that the safety limits will not be exceeded during steady-state operation or as a result of the most severe credible transient.

In the event of a failure of the reactor scram, the self-limiting characteristic due to the large negative coefficient, and the melting of the thermal fuse at a temperature below 120°C, will assure safe shutdown without exceeding a core temperature of 200°C.

3.0 LIMITING CONDITIONS FOR OPERATION

3.1 Reactivity Limits

Applicability

This specification applies to the reactivity condition of the reactor and the reactivity worths of control rods and experiments.

Objective

To assure that the reactor can be shutdown at all times and that the safety limits will not be exceeded.

Specification

- a. The available excess reactivity with all control and safety rods fully inserted and including the potential reactivity worth of all experiments shall not exceed 0.65% $\Delta k/k$ (\$0.878) referenced to 20°C.
- b. The shutdown margin with the most reactive safety or control rod fully inserted and the fine control rod fully inserted shall be at least 1% $\Delta k/k$ (\$1.35).
- c. The reactivity worth of the control and safety rods shall ensure subcriticality on the complete withdrawal of the coarse control rod or any one safety rod.

Basis

The limitations on total core excess reactivity assure reactor periods of sufficient length so that the reactor protection system and/or operator action will be able to shut the reactor down without exceeding any safety limits. The shutdown margin and control and safety rod reactivity limitations assure that the reactor can be brought and maintained subcritical if the highest reactivity scrammable rod fails to scram and the Fine Control Rod remains in its most reactive position.

3.2 Control and Safety Systems

Applicability

These specifications apply to the reactor control and safety systems.

Objective

To specify lowest acceptable level of performance, instrument set points, and the minimum number of operable components for the reactor control and safety systems.

Specification

- a. The total scram withdrawal time of the safety rods and coarse control rod shall be less than 1 second.
- b. The average reactivity addition rate for each control or safety rod shall not exceed 0.065% $\Delta k/k$ per second (0.00877 per second).
- c. The safety rods and coarse control rod shall be interlocked such that:
 - (1) Reactor startup cannot commence unless both safety rods and coarse control rods are fully withdrawn from the core.
 - (2) Only one safety rod can be inserted at a time.
 - (3) The coarse control rod cannot be inserted unless both safety rods are fully inserted.
- d. All reactor safety system instrumentation shall be operable in accordance with Table 3.1 with the exception that, with the approval of the Reactor Supervisor, Safety Channel No. 1 may be bypassed whenever the reactor control or safety rods are not in their fully withdrawn position.
- e. The shield water interlock shall be set to prevent startup and scram the reactor if the shield water level falls 10 inches below the highest point on the reactor shield tank manhole opening.
- f. The shield water temperature interlock shall be set to prevent reactor startup and scram the reactor if the shield water temperature falls below 15°C.
- g. The seismic displacement interlock sensor shall be set to prevent reactor startup and scram the reactor during a seismic displacement.
- h. A manual scram shall be provided on the reactor console.
- i. A loss of electric power shall cause the reactor to scram.
- j. An operable installed area radiation monitor capable of detecting gamma radiation shall be immediately available to reactor operating personnel whenever the reactor is not secured. When required monitors are inoperable, portable instruments may be substituted for any installed monitor for periods up to two weeks, while the installed monitor is being repaired.

Basis

The specifications on scram withdrawal time in conjunction with the safety system instrumentation and set points assure safe reactor shutdown during the most severe foreseeable transients. Interlocks on control and safety rods assure an orderly approach to criticality and an adequate shutdown capability. The limitations on reactivity addition rates allow only relatively slow increases of reactivity so that ample time will be available for manual or automatic scram during any operating conditions.

The neutron detector channels (Nuclear Safety Channels Nos. 1 through 3) assure that reactor power levels are adequately monitored during reactor startup and operation. Requirements on minimum neutron levels will prevent reactor startup unless channels are operable and responding, and will cause a scram in the event of instrumentation failure. The power levels initiate redundant automatic protective action at power level scrams low enough to assure safe shutdown without exceeding any safety limits. The period scram conservatively limits the rate of rise of reactor power to periods which are manually controllable and will automatically scram the reactor in the event of unexpected large reactivity additions.

The AGN-201's negative temperature coefficient of reactivity causes a reactivity increase with decreasing core temperature. The shield water temperature interlock will prevent reactor operation at temperatures below 15°C thereby limiting potential reactivity additions associated with temperature decreases.

Water in the shield tank is an important component of the reactor shield and operation without the water may produce excessive radiation levels. The shield tank water level interlock will prevent reactor operation without adequate water levels in the shield tank.

The reactor is designed to withstand 0.6g accelerations and 6 cm displacements. A seismic instrument causes a reactor scram whenever the instrument receives a horizontal acceleration that causes a horizontal displacement of 1/16 inch or greater. The seismic displacement interlock assures that the reactor will be scrammed and brought to a subcritical configuration during any seismic disturbance that may cause damage to the reactor or its components.

The manual scram allows the operator to manually shut down the reactor if an unsafe or otherwise abnormal condition occurs that does not otherwise scram the reactor. A loss of electrical power de-energizes the safety and coarse control rod holding magnets causing a reactor scram and thus assuring safe and immediate shutdown in case of a power outage.

An area radiation monitor must always be available to operating personnel to provide an indication of any abnormally high radiation levels so that appropriate action can be taken to shut down the reactor and assess the hazards to personnel.

Reactor control and safety systems set-point specifications.

<u>SAFETY CHANNEL</u>	<u>SET POINT</u>	<u>FUNCTION</u>
Nuclear Safety Channel No. 1 (Startup Count Rate Channel) Low Power	5% Full Scale	Scram at levels < 5% of Full Scale
Nuclear Safety Channel No. 2 (Log Power Channel) High Power	6 watts (120% of licensed power)	Scram at power > 6 watts
Nuclear Safety Channel No. 2 (Log Power Channel) High Power	3.0×10^{-13} amps	Scram at source levels < 3.0×10^{-13} amps
Reactor Period	5 sec	Scram at periods < 5 sec
Nuclear Safety Channel No. 3 (Linear Power Channel) High Power	6 watts (120% of licensed power)	Scram at power > 6 watts
Nuclear Safety Channel No. 3 (Linear Power Channel) Low Power	5% Full Scale	Scram at levels < 5% of Full Scale
Manual Scram	----	Scram at operator option
Area Radiation Monitor	≤ 10 mR/hr	Alarm at or below level set to meet requirements of 10 CFR 20

3.3 Limitations on Experiments

Applicability

This specification applies to experiments installed in the reactor and its experimental facilities.

Objective

To prevent damage to the reactor or excessive release of radioactive materials in the event of an experiment failure.

Specification

- a. Experiments containing materials corrosive to reactor components or which contain liquid or gaseous, fissionable materials shall be doubly encapsulated.
- b. Explosive materials shall not be inserted into experimental facilities or the reactor or stored within the confines of the reactor facility.

- c. The radioactive material content, including fission products of any experiment shall be limited so that the complete release of all gaseous, particulate, or volatile components from the experiment will not result in:
 - (1) A total effective dose equivalent to any person occupying an unrestricted area continuously for a period of two hours starting at the time of release in excess of 0.1 mSv (10 mrem) as a result of any airborne pathway, or
 - (2) A total effective dose equivalent to any person occupying an unrestricted area continuously for a period of two hours starting at the time of release in excess of 1 mSv (100 mrem) as a result of all pathways, or
 - (3) A total effective dose equivalent to any radiation worker occupying a restricted area during the length of time required to evacuate the restricted area in excess of 50 mSv (5 rem).

Basis

These specifications are intended to reduce the likelihood of damage to reactor components and/or radioactivity releases resulting from an experiment failure and to protect operating personnel and the public from excessive radiation doses in the event of an experiment failure. Specification 3.3.c conforms to the regulatory position put forth in 10 CFR 20, issued January, 1993.

3.4 Radiation Monitoring, Control and Shielding

Applicability

These specifications apply to radiation monitoring, control, and reactor shielding required during reactor operation.

Objective

To protect facility personnel and the public from radiation exposure.

Specification

- a. An operable portable and an installed radiation survey instrument capable of detecting gamma radiation shall be immediately available to reactor operating personnel whenever the reactor is not secured.
- b. The reactor room shall be considered a restricted area whenever the reactor is not secured.
- c. The following shielding requirements shall be fulfilled during reactor operation:
 - (1) The reactor shield tank shall be filled with water to a height within 10 inches of the highest point on the manhole opening.

- (2) The thermal column shall be filled with water or graphite except during a critical experiment (core loading) or during measurement of reactivity worth of thermal column water or graphite, or when the neutron radiography collimator is being used, or other approved experiments which require the thermal column to be empty.
- (3) The movable shield doors above the thermal column shall be maintained in a closed position whenever the reactor is operated at a power greater than 0.5 watts.

Basis

Radiation surveys performed under the supervision of a qualified health physicist have shown that the total gamma, thermal neutron, and fast neutron radiation dose rate in the reactor room, at the closest approach to the reactor outside the designated high radiation area is less than 250 $\mu\text{Sv/hr}$ (25 mrem/hr) at reactor power levels less than 5.0 watts.

The facility shielding in conjunction with designated restricted radiation areas is designed to limit radiation doses to facility personnel and to the public to a level below 10 CFR 20 limits under operating conditions, and to a level below Criterion 19, Appendix A, 10 CFR 50 recommendations under accident conditions.

4.0 SURVEILLANCE REQUIREMENTS

Actions specified in this section are not required to be performed if during the specified surveillance period the reactor has not been brought critical or is maintained in a shutdown condition extending beyond the specified surveillance period. However, the surveillance requirements must be fulfilled prior to subsequent startup of the reactor.

4.1 Reactivity Limits

Applicability

This specification applies to the surveillance requirements for reactivity limits.

Objective

To assure that reactivity limits for Specifications 3.1 are not exceeded.

Specification

- a. Safety and control rod reactivity worths shall be measured annually.
- b. Total excess reactivity and shutdown margin shall be determined annually.
- c. The reactivity worth of an experiment shall be estimated or measured, as appropriate, before or during the first startup subsequent to the experiment's insertion.

Basis

The control and safety rods are inspected and their reactivity worths measured annually to assure that no degradation or unexpected changes have occurred which could adversely affect reactor shutdown margin or total excess reactivity. The shutdown margin and total excess reactivity are determined to assure that the reactor can always be safely shutdown with one rod not functioning and that the maximum possible reactivity insertion will not result in reactor periods shorter than those that can be adequately terminated by either operator or automatic action. Based on experience with AGN reactors, significant changes in reactivity or rod worth are not expected within a 15-month period.

4.2 Control and Safety System

Applicability

This specification applies to the surveillance requirements of the reactor control and safety system.

Objective

To assure that the reactor control and safety systems are operable as required by Specification 3.2.

Specification

- a. Safety and control rod scram times and average reactivity insertion rates shall be measured annually.
- b. Safety and control rods and drives shall be inspected for deterioration at intervals not to exceed 2 years.
- c. A channel test of the following safety channels shall be performed prior to the first reactor startup of the day or prior to each operation extending more than one day.

Nuclear Safety Channel No. 1, No. 2, and No. 3 Manual Scram

- d. A channel test of the seismic displacement interlock shall be performed annually.
- e. A channel check of the following safety channels shall be performed daily whenever the reactor is in operation:

Nuclear Safety Channel No. 1, No. 2, and No. 3

- f. Prior to each day's operation or prior to each operation extending more than one day, Safety Rod No. 1 shall be inserted and scrammed to verify operability of the manual scram system.
- g. The period, count rate, and power level measuring channels shall be calibrated and set point verified annually.
- h. The shield water level interlock, shield water temperature interlock, and seismic displacement safety channel shall be calibrated by perturbing the sensing element to the appropriate set point. These calibrations shall be performed annually.
- i. The radiation monitoring instrumentation shall be calibrated annually.

Basis

The channel tests and checks required daily or before each startup will assure that the safety channels and scram functions are operable. Based on operating experience with reactors of this type, the annual scram measurements, channel calibrations, set point verifications, and inspections are of sufficient frequency to assure, with a high degree of confidence, that the safety system settings will be within acceptable drift tolerance for operation.

4.3 Reactor Structure

Applicability

This specification applies to the surveillance requirements for reactor components other than control and safety rods.

Objective

To assure integrity of the reactor structures.

Specification

- a. The shield tank shall be visually inspected every two years. If apparent excessive corrosion or other damage is observed, corrective measures shall be taken prior to subsequent reactor operation.
- b. Visual inspection for water leakage from the shield tank shall be performed prior to each startup. Leakage sufficient to leave a puddle on the floor shall be corrected prior to subsequent reactor operation.

Basis

Based on experience with reactors of this type, the frequency of inspection and leak test requirements of the shield tank will assure capability for radiation protection during reactor operation.

4.4 Radiation Monitoring and Control

Applicability

This specification applies to the surveillance requirements of the radiation monitoring and control systems.

Objective

To assure that the radiation monitoring and control systems are operable and that all radiation areas within the reactor facility are identified and controlled as required by Specification 3.4.

Specification

- a. All portable and installed radiation survey instruments assigned to the reactor facility shall be calibrated annually under the supervision of the Radiation Safety Officer.
- b. Prior to each day's reactor operation or prior to each reactor operation extending more than one day, the reactor room high radiation alarm shall be verified to be operable.
- c. A radiation survey of the reactor room and reactor control room shall be performed under the supervision of the Radiation Safety Officer annually, to determine the location of radiation and high radiation areas corresponding to reactor operating power levels.

Basis

The periodic calibration of radiation monitoring equipment and the surveillance of the reactor room high radiation area alarm will assure that the radiation monitoring and control systems are operable during reactor operation.

The periodic radiation surveys will verify the location of radiation and high radiation areas and will assist reactor facility personnel in properly labeling and controlling each location in accordance with 10 CFR 20.

5.0 DESIGN FEATURES

5.1 Reactor

- a. The reactor core, including control and safety rods, contains approximately 670 grams of ^{235}U in the form of <20% enriched UO_2 dispersed in approximately 11 kilograms of polyethylene. The lower section of the core is supported by an aluminum rod hanging from a fuse link. The fuse melts at temperatures below 120°C causing the lower core section to fall away from the upper section reducing reactivity by at least 5% $\Delta k/k$. Sufficient clearance between core and reflector is provided to insure free fall of the bottom half of the core during the most severe transient.
- b. The core is surrounded by a 20-cm-thick high-density (1.75 gm/cm^3) graphite reflector followed by a 10-cm-thick lead gamma shield. The core and part of the graphite reflector are sealed in a fluid-tight aluminum core tank designed to contain any fission-product gases that might leak from the core.
- c. The core, reflector, and lead shielding are enclosed in and supported by a fluid-tight steel reactor tank. An upper or "thermal column tank" may serve as a shield tank when filled with water or as a thermal column when filled with graphite.
- d. The 198-cm-diameter, fluid-tight shield tank is filled with water constituting a 55-cm-thick fast neutron shield. The fast neutron shield is formed by filling the tank with approximately 3858 liters of water. The complete reactor shield shall limit doses to operating personnel in restricted and unrestricted areas to levels less than permitted by 10 CFR 20 under operating conditions.
- e. Shielding is provided by a concrete wall constructed of $4" \times 8" \times 16"$ concrete blocks and $4" \times 8" \times 12"$ barytes concrete blocks for 5 watt operation. The blocks are held to close dimensional tolerance in manufacture and stacked in such a manner that voids in the completed wall are at a minimum. Near the beam ports and the base. The use of these blocks further reduces radiation level in these areas. Overhead shielding is provided by 8-inch thick barytes blocks (minimum density 3.7 gm/cm^3). Results of shielding calculations are summarized in the ISU AGN-201 Reactor Safety Analysis Report.
- f. Two safety rods and one control rod (identical in size) contain up to 20 grams of ^{235}U each in the same form as the core material. These rods are lifted into the core by electromagnets, driven by reversible DC motors through lead screw assemblies. De-energizing the magnets cause a spring-driven, gravity-assisted scram. The fourth rod or fine control rod (approximately one-half the diameter of the other rods) is driven directly by a lead screw. This rod may contain polyethylene with or without fuel.

5.2 Fuel Storage

Fuel, including fueled experiments and fuel devices not in the reactor, shall be stored in locked rooms in the College of Engineering laboratories. The storage array shall be such that k_{eff} is no greater than 0.9 for all conditions of moderation and reflection.

5.3 Reactor Room

- a. The reactor room houses the reactor assembly and accessories required for its operation and maintenance.
- b. The reactor room is a separate room in the Lillibridge Engineering Laboratory, constructed with adequate shielding and other radiation protective features to limit doses in restricted areas and unrestricted areas, to levels no greater than permitted by 10 CFR 20, under normal operating conditions, and to a level below Criterion 19, Appendix A, 10 CFR 50 recommendations under accident conditions.
- c. Access doors to the reactor room are self-locking.

6.0 ADMINISTRATIVE CONTROLS

6.1 Organization

The administrative organization for control of the reactor facility and its operation shall be as set forth in figure 1. The authorities and responsibilities set forth below are designed to comply with the intent and requirements for administrative controls of the reactor facility as set forth by the Nuclear Regulatory Commission.

6.1.1 University Officer

The University officer is an administrative officer responsible for the University and in whose name the application for licensing is made.

6.1.2 Dean, College of Engineering

The dean of the College of Engineering is the administrative officer responsible for the operation of the College of Engineering.

6.1.3 Reactor Administrator

The Reactor Administrator (RA) is the administrative officer responsible for the operation of the AGN-201M Reactor Facility. In this capacity the RA shall have final authority and ultimate responsibility for the operation, maintenance, and safety of the reactor facility within the limitations set forth in the facility license. The Reactor Administrator shall be responsible for appointing the Reactor Supervisor, who reports to the Reactor Administrator. The RA shall seek the advice and approval of the Radiation Safety Committee and/or the Reactor Safety Committee in all matters concerning unresolved safety questions, new experiments and new procedures, and facility modifications which might affect safety. The RA shall be an ex officio member of the Reactor Safety Committee.

6.1.4 Reactor Supervisor

The Reactor Supervisor (RS) shall be responsible for the preparation, promulgation, and enforcement of administrative controls including all rules, regulations, instructions, and operating procedures to ensure that the reactor facility is operated in a safe, competent, and authorized manner at all times. The RS shall direct the activities of operators and technicians in the daily operation and maintenance of the reactor; schedule reactor operations and maintenance; be responsible for the preparation, authentication, and storage of all prescribed logs and operating records; authorize all experiments, procedures, and changes thereto which have received the approval of the Reactor Safety Committee and/or the Radiation Safety Committee and the RA; and be responsible for the preparation of experimental procedures involving the use of the reactor. The RS shall hold a valid Senior Reactor Operator's license issued by the U.S. Nuclear Regulatory Commission.

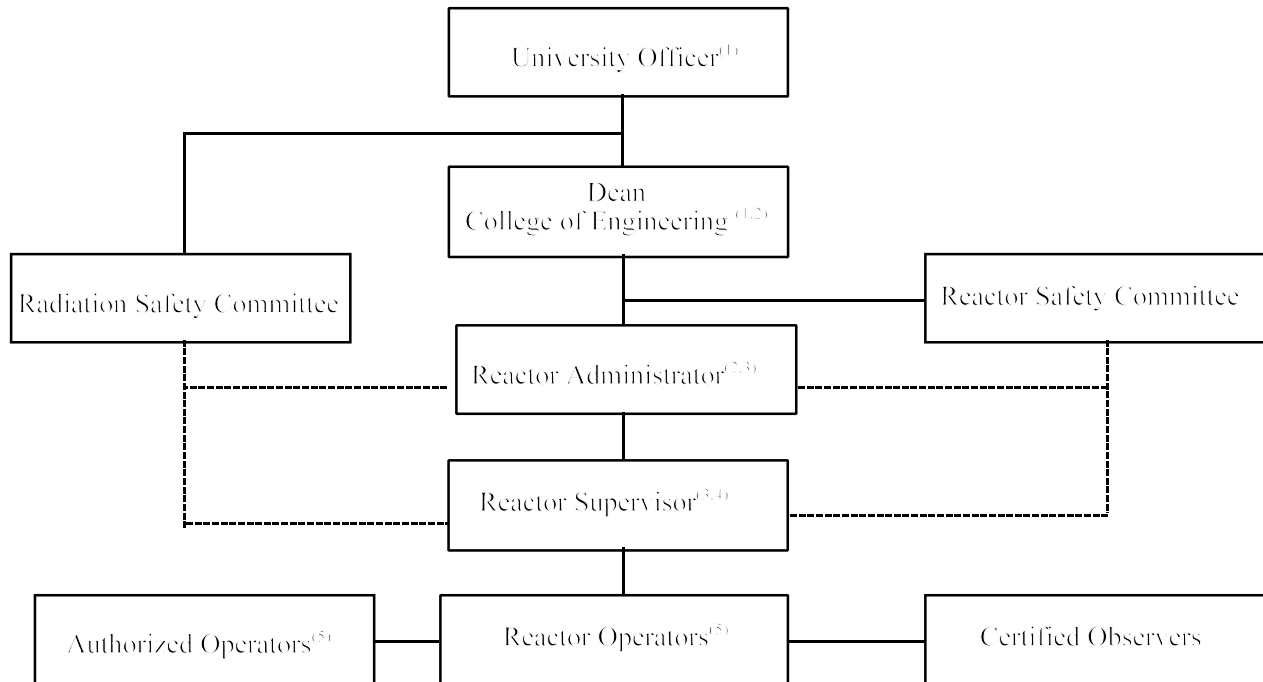

- ⁽¹⁾ University Officer and Dean of the College of Engineering may be same individual.
- ⁽²⁾ Dean of the College of Engineering and Reactor Administrator may be same individual.
- ⁽³⁾ Reactor Administrator and Reactor Supervisor may be same individual.
- ⁽⁴⁾ Requires NRC Senior Reactor Operators License.
- ⁽⁵⁾ Requires NRC Reactor Operators License except where exempt per 10 CFR 55.13.

Figure 1. Administrative Organization of the ISU AGN-201M Reactor Facility, NRC License R-110

Persons holding positions on the Administrative organization shall meet or exceed the qualification requirements of ANSI/ANS-15.4-1988, “Selection and Training of Personnel for Research Reactors.”

6.1.5 Reactor Operators

Reactor Operators shall be responsible for the manipulation of the reactor controls, monitoring of instrumentation, operation of reactor-related equipment, and maintenance of complete and current records during operation of the facility. Reactor Operators shall hold a valid Reactor Operator’s license issued by the U.S. Nuclear Regulatory Commission.

6.1.6 Authorized Operators

Individuals authorized by the Reactor Supervisor to operate the reactor controls and who do so with the knowledge of the Reactor Supervisor and under the direct supervision of a Reactor Operator.

6.1.7 Certified Observers

Individuals certified by the Reactor Supervisor as qualified to activate manual scram and initiate emergency procedures in the event of an emergency situation during reactor operation.

6.1.8 Reactor Safety Committee

The Reactor Safety Committee shall be responsible for, but not limited to, reviewing and approving safety standards associated with the use of the reactor facility; reviewing and approving all proposed experiments and procedures and changes thereto; reviewing and approving all modifications to the reactor facility which might affect its safe operation; determining whether proposed experiments, procedures, or modifications involve unreviewed safety questions, as defined in 10 CFR 50.59, and are in accordance with these Technical Specifications; conducting periodic audits of procedures, reactor operations and maintenance, equipment performance, and records; review all reportable occurrences and violations of these Technical Specifications, evaluating the causes of such events and the corrective action taken and recommending measures to prevent reoccurrence; reporting all their findings and recommendations to prevent reoccurrence; reporting all their findings and recommendations concerning the reactor facility to the Reactor Administrator.

6.1.9 Radiation Safety Committee

The Radiation Safety Committee shall advise the University administration and the Radiation Safety Officer on all matters concerning radiological safety at University facilities.

6.1.10 Radiation Safety Officer

The Radiation Safety Officer shall review and approve all procedures and experiments involving radiological safety. He shall enforce all federal, state, and university rules, regulations, and procedures relating to radiological safety. He shall perform routine radiation surveys of the reactor facility and report his findings to the Reactor Administrator. He shall provide personnel dosimetry and keep records of personnel radiation exposure. He shall advise the Reactor Administrator on all matters concerning radiological safety at the reactor facility. The Radiation Safety Officer shall be an ex officio member of the Reactor Safety Committee.

6.1.11 Operating Staff

- a. The minimum operating staff during any time in which the reactor is not secured shall consist of:
 - (1) One licensed Reactor Operator in the reactor control room.
 - (2) One Certified Observer in the reactor control room.
 - (3) One licensed Senior Reactor Operator readily available on call. This requirement can be satisfied by having a licensed Senior Reactor Operator perform the duties stated in paragraph (1) or (2)

above or by designating a licensed Senior Reactor Operator who can be readily contacted by telephone and who can arrive at the reactor facility within 30 minutes.

- b. A licensed Senior Reactor Operator shall supervise all reactor maintenance or modification which could affect the reactivity of the reactor.
- c. A listing of reactor facility personnel by name and phone number shall be conspicuously posted in the reactor control room.

6.2 Staff Qualifications

The Reactor Administrator, the Reactor Supervisor, licensed Reactor Operators, and technicians performing reactor maintenance shall meet the minimum qualifications set forth in ANSI/ANS-15.4, "Standards for Selection and Training of Personnel for Research Reactors." Reactor Safety Committee members shall have a minimum of five (5) years experience in their profession or a baccalaureate degree and two (2) years of professional experience. Generally, these committee members will be made up of University faculty, but outside experience will be sought in areas where additional experience is considered necessary by the Reactor Administrator.

6.3 Training

The Reactor Supervisor shall be responsible for directing training as set forth in ANSI/ANS-15.4, "Standards for Selection and Training of Personnel for Research Reactors." All licensed reactor operators shall participate in requalification training as set forth in 10 CFR 55.

6.4 Reactor Safety Committee

6.4.1 Meetings and Quorum

The Reactor Safety Committee (RSC) shall meet as often as deemed necessary by the RSC chair but shall meet at least annually. A quorum for the conduct of official business shall consist of not less than one-half of the current RSC membership and shall include the Chair or designated alternate. At no time shall the operating organization comprise a voting majority of the members at any RSC meeting.

6.4.2 Reviews

The RSC shall review:

- a. Safety evaluations for changes to procedures, equipment or systems, and tests or experiments, conducted without Nuclear Regulatory Commission approval under the provision of 10 CFR 50.59, to verify that such actions do not constitute an unreviewed safety question.
- b. Proposed changes to procedures, equipment or systems that change the original intent or use, are non-conservative, or those that involve an unreviewed safety question as defined in 10 CFR 50.59.
- c. Proposed tests or experiments which are significantly different from previously approved tests or experiments, or those that involve an unreviewed safety question as defined in 10 CFR 50.59.
- d. Proposed changes in Technical Specifications or other license documents.
- e. Violations of applicable statutes, codes, regulations, orders, Technical Specifications, license requirements, or of internal procedures or instructions having nuclear safety significance.
- f. Significant operating abnormalities or deviations from normal and expected performance of facility equipment that affect nuclear safety.
- g. Reportable occurrences.
- h. Audit reports.

6.4.3 Audits

Audits of facility activities shall be performed under the cognizance of the RSC but in no case by the personnel responsible for the item audited. These audits shall examine the operating records and encompass but shall not be limited to the following:

- a. The conformance of facility operation to the Technical Specifications and applicable license condition, at least annually.
- b. The performance, training, and qualifications of the entire facility staff, at least every two years.
- c. The results of all actions taken to correct deficiencies occurring in facility equipment, structures, systems or method of operation that affect nuclear safety, at least annually.
- d. The Facility Emergency Plan and implementing procedures at least every two years.
- e. The Facility Security Plan and implementing procedures, at least every two years.

6.4.4 Authority

The RSC shall report to the Dean of the College of Engineering and shall advise the Reactor Administrator on those areas of responsibility outlined in Section 6.1.6 of these Technical Specifications.

6.4.5 Minutes of the Reactor Safety Committee

The RSC Chair shall direct the preparation, maintenance, and distribution of minutes of its activities. These minutes shall include a summary of all meetings, actions taken, audits, and reviews. Minutes should be distributed to all administrative levels and RSC members within 3 months after each meeting.

6.5 Approvals

The procedure for obtaining approval for any change, modification or procedure which requires approval of the RSC shall be as follows:

- a. The Reactor Supervisor shall prepare the proposal for review and approval by the Reactor Administrator.
- b. The Reactor Administrator shall submit the proposal to the RSC for review, comment, and possible approval.
- c. The RSC shall approve the proposal by majority vote.
- d. The Reactor Administrator shall provide final approval after receiving the approval of the RSC.

6.6 Procedures

There shall be written procedures that cover the following activities:

- a. Startup, operation, and shutdown of the reactor.
- b. Fuel Movement and changes to the core and experiments that could affect reactivity.
- c. Conduct of irradiations and experiments that could affect the safety of the reactor.
- d. Preventative or corrective maintenance which could affect the safety of the reactor.
- e. Surveillance, testing, and calibration of instruments, components and systems as specified in Section 4.0 of these Technical Specifications.
- f. Implementation of the Security Plan and Emergency Plan.
- g. Radiation Safety Protection for all reactor related personnel.

The above listed procedures shall be approved by the Reactor Administrator and the RSC. Temporary procedures which do not change the intent of previously approved procedures and which do not involve any unreviewed safety question may be employed on approval by the Reactor Supervisor.

6.7 Experiments

- a. Prior to initiating any new reactor experiment, an experimental procedure shall be prepared by the Reactor Supervisor and reviewed and approved by the Reactor Administrator and the RSC.
- b. Approved experiments shall only be performed under the cognizance of the Reactor Supervisor.

6.8 Safety Limit Violation

The following actions shall be taken in the event a Safety Limit is violated:

- a. The reactor will be shutdown immediately and reactor operation will not be resumed without authorization by the Nuclear Regulatory Commission (NRC).
- b. The Safety Limit violation shall be reported to the Reactor Administrator immediately. The violation shall be reported to the NRC and the RSC Chair or designated alternate not later than the next working day.
- c. A Safety Limit Violation Report shall be prepared for review by the RSC. This report shall describe the applicable circumstances leading to the violation including, when known, the cause and contributing factors; the effects of the violation upon facility components, systems, or structures and on the health and safety of personnel and the public; and corrective action to prevent recurrence.
- d. A Safety Limit Violation Report shall be submitted to the NRC and RSC within 14 days of the violation.

6.9 Reporting Requirements

In addition to the applicable reporting requirements of Title 10, Code of Federal Regulations, the following reports shall be submitted to the Director, Office of Nuclear Reactor Regulation, U.S. Nuclear Regulatory Commission, Attention: Document Control Desk, Washington, D.C., 20555

6.9.1 Annual Operating Report

Routine operating reports covering the operation of the reactor during the previous calendar year should be submitted prior to June 30 of each year. The annual operating reports made by licensees shall provide a comprehensive summary of the operating experience having safety significance that was gained during the year, even though some repetition of previously reported information may be involved. References in the annual operating report to previously submitted reports shall be clear.

Each annual operating report shall include:

- (1) A brief narrative summary of:

- a. Changes in facility design, performance characteristics, and operating procedures relating to reactor safety that occurred during the reporting period.
 - b. Results of major surveillance tests and inspections.
- (2) A monthly tabulation showing the hours the reactor was operated and the energy produced by the reactor in watt-hours.
 - (3) List of the unscheduled shutdowns, including the reasons therefore and corrective action taken, if any.
 - (4) Discussion of the major safety-related corrective maintenance performed during the period, including the effects, if any, on the safe operation of the reactor and the reasons for the corrective maintenance required.
 - (5) A brief description of:
 - a. Each change to the facility to the extent that it changes a description of the facility in the application for license and amendments thereto.
 - b. Changes to the procedures as described in Facility Technical Specifications.
 - c. Any new or untried experiments or tests performed during the reporting period.
 - (6) A summary of the safety evaluation made for each change, test, or experiment not submitted for NRC approval pursuant to 10 CFR 50.59 which clearly shows the reason leading to the conclusion that no unreviewed safety question existed and that no change to the Technical Specifications was required.
 - (7) A summary of the nature and amount of radioactive effluents released or discharged to the environs beyond the effective control of the licensee as determined at or prior to the point of such release or discharge.
 - a. Liquid Waste

Total estimated quantity of radioactivity released (in curies) and total volume (in liters) of effluent water (including diluent) released.
 - b. Airborne Waste

Total estimated quantity of radioactivity released (in curies) determined by an approved sampling and counting method.
 - c. Solid Waste
 - (i) Total amount of solid waste packaged (in cubic meters).
 - (ii) Total activity in solid waste (in curies).
 - (iii) The dates of shipments and disposition (if shipped off site).

- (8) A description of the results of any environmental radiological surveys performed outside the facility.
- (9) Radiation Exposure - A summary of radiation exposures received during the reporting period by facility personnel and visitors.

6.9.2 Reportable Occurrences

Reportable occurrences, including causes, probable consequences, corrective actions and measures to prevent recurrence, shall be reported to the NRC. Supplemental reports may be required to fully describe final resolution of the occurrence. In case of corrected or supplemental reports, an amended licensee event report shall be completed and reference shall be made to the original report date.

a. Prompt Notification with Written Follow-up

The types of events listed below are considered reportable occurrences and shall be reported as expeditiously as possible by telephone and confirmed by overnight mail, mailgram, or facsimile transmission to the NRC Document Control Desk no later than the first working day following the event, with a written follow-up report within two weeks. Information provided shall contain narrative material to provide complete explanation of the circumstances surrounding the event.

- (1) Failure of the reactor protective system subject to limiting safety system settings to initiate the required protective function by the time a monitored parameter reached the set point specified as the limiting safety system setting in the technical specifications.
- (2) Operation of the reactor when any parameter or operation subject to a limiting condition is found to be less conservative than the limiting condition for operation established in the technical specifications, without evaluation and permitted remedial action.
- (3) Abnormal degradation discovered in a fission-product barrier.
- (4) Reactivity balance anomalies involving:
 - (i) Disagreement between expected and actual critical positions exceeding 0.3% $\Delta k/k$;
 - (ii) Exceeding excess reactivity limits;
 - (iii) Shutdown margin less conservative than specified in Technical Specifications.
- (5) Failure or malfunction of one (or more) component(s) which prevents, or could prevent, by itself, the fulfillment of the functional requirements of systems used to cope with accidents analyzed in the Safety Analysis Report.
- (6) Personnel error or procedural inadequacy which prevents, or could prevent, by itself, the fulfillment of the functional requirements of

systems required to cope with accidents analyzed in the Safety Analysis Report.

- (7) Errors discovered in the transient or accident analyses or in the methods used for such analyses as described in the Safety Analysis Report or in the basis of the Technical Specifications that have permitted reactor operation in a manner less conservative than assumed in the analyses.
- (8) Performance of structures, systems, or components that requires remedial action or corrective measures to prevent operation in a manner less conservative than assumed in the accident analyses in the Safety Analyses Report or Technical Specifications basis, or discovery during plant life of conditions not specifically considered in the Safety Analysis Report or Technical Specifications that require remedial action or corrective measures to prevent the existence or development of an unsafe condition.
- (9) Deployment of the thermal fuse.

6.9.3 Special Reports

Special reports which may be required by the NRC shall be submitted to the U.S. NRC Document Control Desk within the time period specified for each report. These reports include notification of changes in Level 1, 2, or 3 administration, as defined in ANSI/ANS-15.2 and shown in Figure 1, which shall be reported within 45 days of such a change.

6.10 Record Retention

6.10.1 Records to be retained for a period of at least five years:

- a. Operating logs or data which shall identify:
 - (1) Completion of pre-startup checkout, startup, power changes, and shutdown of reactor.
 - (2) Installation or removal of fuel elements, control rods or experiments that could affect core reactivity.
 - (3) Installation or removal of jumpers, special tags or notices, or other temporary changes to reactor safety circuitry.
 - (4) Rod worth measurements and other reactivity measurements.
- b. Principal maintenance operations.
- c. Reportable Occurrences.
- d. Surveillance activities required by technical specifications.
- e. Facility radiation and contamination surveys.
- f. Experiments performed with the reactor

This requirement may be satisfied by the normal operations log book plus:

- (1) Records of radioactive material transferred from the facility as required by license.
- (2) Records required by the RSC for the performance of new or special experiments.

- g. Records of training and qualification for members of the facility staff.
- h. Changes to operating procedures.

6.10.2 Records to be retained for the life of the facility:

- a. Gaseous and liquid radioactive effluents released to the environs.
- b. Appropriate off-site environmental monitoring surveys.
- c. Fuel inventories and fuel transfers.
- d. Radiation exposures for all personnel.
- e. Updated as-built drawings for the facility.
- f. Records of transient or operational cycles for those components designed for a limited number of transients or cycles.
- g. Records of reviews performed for changes made to procedures or equipment or reviews of tests and experiments pursuant to 10 CFR 50.59.
- h. Records of meetings of the RSC.

UNITED STATES NUCLEAR REGULATORY COMMISSION
NOTICE OF RENEWAL OF FACILITY OPERATING LICENSE NO. R-110
IDAHO STATE UNIVERSITY AGN-201M RESEARCH REACTOR
DOCKET NO. 50-284

The U.S. Nuclear Regulatory Commission (the Commission) has issued Amendment No. 6 to Facility Operating License No. R-110 for the Idaho State University (the licensee), which renews the license for operation of the Idaho State University AGN-201M Research Reactor Facility located at the Idaho State University in Pocatello, Idaho.

The facility is a research reactor that has been operating at a power level not in excess of 5 watts (thermal). The renewed Facility Operating License No. R-110 will expire twenty years from its date of issuance.

The amended license complies with the standards and requirements of the Atomic Energy Act of 1954, as amended (the Act), and the Commission's rules and regulations. The Commission has made appropriate findings as required by the Act and the Commission's regulations in 10 CFR Chapter I. Those findings are set forth in the license amendment. Opportunity for hearing was afforded in the notice of the proposed issuance of this renewal in the FEDERAL REGISTER on January 8, 1996 (61 FR 563). No request for a hearing or petition for leave to intervene was filed following notice of the proposed action.

Continued operation of the reactor will not require alteration of buildings or structures, will not lead to significant changes in effluents released from the facility to the environment, will not increase the probability or consequences of accidents, and will not involve any unresolved issues concerning alternative uses of available resources. Based on the foregoing and on the

Environmental Assessment, the Commission concludes that renewal of the license will not result in any significant environmental impacts.

The Commission has prepared a "Safety Evaluation Report Related to the Renewal of the Operating License for the Research Reactor at Idaho State University" for the renewal of Facility Operating License No. R-110 and has, based on that evaluation, concluded that the facility can continue to be operated by the licensee without endangering the health and safety of the public.

The Commission also prepared an Environmental Assessment which was published in the FEDERAL REGISTER on April 9, 2004, (69 FR 18988) for the renewal of Facility Operating License No. R-110 and has concluded that this action will not have a significant effect on the quality of the human environment.

For further details with respect to this action, see: (1) the application for amendment dated November 21, 1995, as supplemented on January 31, 2003 and July 10, 2003, (2) Amendment No. 6 to Facility Operating License No. R-110; (3) the related Safety Evaluation Report and (4) the Environmental Assessment dated March 30, 2004. Documents may be examined, and/or copied for a fee, at the NRC's Public Document Room, located at One White Flint North, 11555 Rockville Pike (first floor), Rockville, Maryland. The NRC maintains an Agencywide Documents Access and Management System (ADAMS), which provides text and image files of NRC's public documents. Documents related to this license renewal dated on or after November 24, 1999, may be accessed through the NRC's Public Electronic Reading Room on the internet at <http://www.nrc.gov>. If you do not have access to ADAMS or if there are

problems in accessing the documents located in ADAMS, contact the NRC Public Document Room (PDR) Reference staff at 1-800-397-4209, 301-415-4737 or by email to pdr@nrc.gov.

Dated at Rockville, Maryland, this 14th day of August 2006.

FOR THE U.S. NUCLEAR REGULATORY COMMISSION

/RA/

Brian E. Thomas, Chief
Research and Test Reactors Branch
Division of Policy and Rulemaking
Office of Nuclear Reactor Regulation

SAFETY EVALUATION REPORT

related to the renewal of the
operating license for the research
reactor at Idaho State University

DOCKET NO. 50-284

U.S Nuclear Regulatory Commission

Office of Nuclear Reactor Regulation



ABSTRACT

This safety evaluation report (SER) summarizes the findings of a safety review conducted by the staff of the U.S. Nuclear Regulatory Commission (NRC), Office of Nuclear Reactor Regulation (NRR). The staff conducted this review in response to an application filed by Idaho State University (ISU or the licensee) for a 20-year renewal of Facility Operating License R-110 to continue to operate the ISU AGN-201M research reactor. The facility is located in the Lillibridge Engineering Laboratory on the ISU campus in Pocatello, Idaho. In its safety review, the staff considered information submitted by the licensee (including past operating history recorded in the licensee's annual reports to the NRC), as well as inspection reports prepared by NRC personnel and first-hand observations. On the basis of this review, the staff concludes that ISU can continue to operate the AGN-201M research reactor, in accordance with its application, without endangering the health and safety of the public.

CONTENTS

1 INTRODUCTION	1-1
1.1 Overview	1-1
1.2 Summary and Conclusions Regarding the Principal Safety Considerations	1-2
1.3 History	1-3
1.4 Reactor Description	1-3
1.5 Facilities and Equipment	1-4
1.6 Comparison with Similar Facilities	1-4
1.7 Nuclear Waste Policy Act of 1982	1-4
1.8 Conclusions	1-4
2 SITE CHARACTERISTICS	2-1
2.1 Geography and Demography	2-1
2.2 Nearby Industrial, Transportation, and Government Facilities	2-1
2.2.1 Industry	2-1
2.2.2 Transportation	2-1
2.2.3 Government Facilities	2-1
2.3 Meteorology	2-2
2.4 Geology and Seismology	2-2
2.4.1 Site Geology	2-2
2.4.2 Seismology	2-2
2.5 Hydrology	2-2
2.6 Conclusions	2-2
3 STRUCTURE, SYSTEM, AND COMPONENT DESIGN	3-1
3.1 Reactor Facility Description	3-1
3.1.1 Reactor Laboratory	3-1
3.1.2 Reactor Observation Room	3-1
3.2 Wind and Water Damage	3-1
3.3 Seismically Induced Reactor Damage	3-2
3.4 Electro-Mechanical Systems and Components	3-2
3.5 Conclusions	3-2
4 REACTOR	4-1
4.1 Introduction	4-1
4.2 Reactor Core	4-1
4.3 Reflector	4-1
4.4 Shielding	4-1
4.5 Control Rods and Drives	4-1

4.5.1 Safety Rods	4-2
4.5.2 Coarse Control Rod	4-2
4.5.3 Fine Control Rod	4-2
4.6 Dynamic Design Evaluation	4-2
4.6.1 Reactor Physics and Reactivity Control	4-2
4.6.2 Shutdown Margin, Excess Reactivity, and Experiment Reactivity Worth	4-2
4.7 Conclusions	4-3
5 REACTOR COOLING SYSTEM	5-1
6 ENGINEERED SAFETY FEATURES	6-1
7 INSTRUMENTATION AND CONTROL	7-1
7.1 Instrumentation System	7-1
7.1.1 Nuclear Instrumentation	7-2
7.1.2 Process Instrumentation	7-2
7.2 Nuclear Control System	7-3
7.3 Conclusions	7-3
8 ELECTRICAL POWER	8-1
8.1 Normal Electrical Power System	8-1
8.2 Emergency Electrical Power System	8-1
8.3 Conclusions	8-1
9 AUXILIARY SYSTEMS	9-1
9.1 Fuel Storage and Handling	9-1
9.2 Fire Protection System	9-1
9.3 Communications System	9-1
9.4 Ventilation System	9-1
9.5 Conclusions	9-1
10 EXPERIMENTAL FACILITIES	10-1
10.1 Glory Hole	10-1
10.2 Access Ports	10-1
10.3 Thermal Column	10-1
10.4 Pneumatic Tube System (Rabbit)	10-1
10.5 Limits, Reviews, and Conduct of Experiments	10-1
10.6 Conclusion	10-2
11 RADIATION PROTECTION AND	

WASTE MANAGEMENT PROGRAM	11-1
11.1 Radiation Protection Program	11-1
11.1.1 ALARA Commitment	11-1
11.1.2 Health Physics Staffing	11-1
11.1.3 Health Physics Procedures	11-1
11.1.4 Health Physics Training	11-2
11.1.5 Radiation Sources	11-2
11.1.6 Routine Monitoring	11-2
11.2 Radioactive Waste Generation and Management	11-2
11.3 Conclusions	11-3
12 CONDUCT OF OPERATIONS	12-1
12.1 Overall Organization	12-1
12.2 Training	12-1
12.3 Operational Review and Audits	12-1
12.4 Procedures	12-1
12.5 Emergency Planning	12-2
12.6 Physical Security Plan	12-2
12.7 Conclusions	12-3
13 ACCIDENT ANALYSES	13-1
13.1 Maximum Hypothetical Accident (MHA)	13-1
13.2 Loss of Shield Tank Water	13-1
13.3 Conclusions	13-2
14 TECHNICAL SPECIFICATIONS	14-1
15 FINANCIAL QUALIFICATIONS	15-1
16 PRIOR UTILIZATION AND AGING	16-1
16.1 Prior Utilization	16-1
16.2 Conclusion	16-1
17 CONCLUSIONS	17-1

LIST OF FIGURES

Figure 4.1	Reactor Core	4-4
Figure 7.1	Control System	7-4
Figure 7.2	Simplified Safety Chassis Circuit Diagram	7-5
Figure 11.1	Idaho State University Radiation Protection Organizational Chart	11-4
Figure 12.1	AGN-201M Reactor Administrative Organizational Chart	12-2

1 INTRODUCTION

1.1 Overview

The Idaho State University (the licensee or ISU) submitted an application to the U.S. Nuclear Regulatory Commission (NRC) for a 20-year renewal of the Class 104c Facility Operating License (NRC Docket No. 50-284). The renewal application consisted of a letter and supporting documentation dated November 21, 1995, as supplemented on January 31, 2003 and July 11, 2003. This license renewal would authorize continued operation of the ISU AGN-201M research reactor as a NRC-licensed facility.

The application included financial qualifications, the safety analysis report (SAR), proposed technical specifications (TS), the operator requalification program, the emergency plan, the physical security plan and the environmental report. Except for the physical security plan, this material is available for review in the Commission's Public Document Room. The facility's physical security plan is protected from public disclosure under 10 CFR Part 2.790.

In conducting its safety review, the NRC staff evaluated the facility against the requirements of 10 CFR Parts 20, 30, 50, 51, 55, 70, and 73; applicable regulatory guides (RGs); relevant accepted industry standards, such as the American National Standards Institute/American Nuclear Society (ANSI/ANS) 15 series; and NRC guidance documents, such as NUREG-1537, "Guidelines for Preparing and Reviewing Applications for the Licensing of Non-Power Reactors." The NRC staff review used NUREG-1537 as the primary guidance document.

The purpose of this safety evaluation report (SER) is to summarize the findings of the NRC staff's safety review for operation of the ISU AGN-201M research reactor. This SER will be part of the bases for issuing an NRC license renewal. The licensee authorizes operation at steady-state thermal power levels up to a maximum of 5 watts (thermal).

The sections of this SER are as follows:

- Chapter 1 summarizes the conclusions regarding the principal safety considerations of the NRC staff SER, the history and general description of the reactor facility, information on shared facilities and equipment, comparison with similar facilities, and how the licensee complies with the Nuclear Waste Policy Act of 1982.
- Chapter 2 is on the site and applicable site characteristics, including geography, demography, meteorology, hydrology, geology, and interaction with nearby installations and facilities.
- Chapter 3 is on the design bases of facility structures, systems, and components, and the responses to environmental factors at the reactor site.
- Chapter 4 is on the review of the design bases of the reactor core and its components.
- Chapter 5 is on the review of the reactor core cooling system.
- Chapter 6 is on the design bases of engineered safety features (ESFs) to mitigate consequences of postulated accidents at the facility.
- Chapter 7 is on the design bases of instrumentation and control (I&C) systems and subsystems at the facility.
- Chapter 8 is on the design bases for normal and emergency electrical power systems at the

facility.

- Chapter 9 is on the design bases of auxiliary systems, such as fuel handling and storage, warning and communication, and fire protection.
- Chapter 10 is on the design bases of the experimental facilities and programs.
- Chapter 11 is on the design bases of the radiation protection and radioactive waste management programs and facilities.
- Chapter 12 is on the conduct of facility operations. This includes consideration of the management structure and responsibilities, provisions for review by the Reactor Operations Committee, and other required functions such as the procedures, reporting, and operator requalification, security and emergency plans.
- Chapter 13 is on the bases, scenarios, and accident analyses at the reactor facility.
- Chapter 14 is on the TSs operating limits, conditions and other requirements for the facility.
- Chapter 15 is on the financial qualifications of the licensee for continuing operations and decommissioning.
- Chapter 16 is on previous reactor utilization.
- Chapter 17 summarizes the major conclusions of the NRC staff's review of the license renewal application.

This SER was prepared by Mr. Paul V. Doyle Jr., Senior Operator Licensing Examiner, from the NRC's Office of Nuclear Reactor Regulation (NRR), Division of Policy and Rulemaking, Research and Test Reactors Branch.

1.2 Summary and Conclusions Regarding the Principal Safety Considerations

As part of its evaluation, the staff considered information submitted by the licensee (i.e., licensee annual reports to the NRC), as well as inspection reports prepared by the NRC. On the basis of this the NRC staff reached the following conclusions:

- (1) The design, testing, and performance of the research reactor structures, systems and components important to safety during normal operation were adequately planned and can reasonably be expected to continue safely.
- (2) The licensee's management organization, is adequate to maintain and operate the reactor so that there is no significant radiological risk to the facility's employees or the public.
- (3) The licensee's qualifications, training, experimental activities, and security measures are adequate to ensure safe operation of the facility and protection of its special nuclear material.
- (4) The licensee and the NRC staff have considered the expected consequences of several postulated accidents emphasizing those likely to cause a loss of integrity of fuel-element cladding. The NRC staff confirmed conservative analyses of the most serious, hypothetically credible accidents. As a result, the NRC staff determined that the calculated potential radiation

doses outside the reactor site are not likely to exceed the guidelines for doses in unrestricted areas, as specified by 10 CFR Part 20 and Appendices for research reactors initially licensed before January 1, 1994.

- (5) The radiation protection program, and the radioactive materials and wastes control program acceptably continue to control radiological exposures and concentrations within the limits and principles specified 10 CFR Part 20 including the principle of as low as reasonably achievable (ALARA).
- (6) The licensee's TSs give a reasonable assurance that the facility will continue to operate acceptably according to the assumptions and analyses in the SAR. Neither the licensee, through surveillance, nor the NRC through audits has not noted any significant degradation of equipment. The TS required surveillance and safety committee oversight will continue to ensure no significant degradation of equipment.
- (7) The financial data submitted with the application demonstrate that the licensee has reasonable access to sufficient revenues to cover operating costs and eventually to decommission the reactor facility acceptably.
- (8) The licensee's program for physically protecting the facility and its special nuclear materials continues to comply with the requirements of 10 CFR Part 73.
- (9) The licensee's procedures for operator requalification continue to give reasonable assurance that ISU will operate the reactor acceptably.
- (10) The licensee's emergency plan provides reasonable assurance that the licensee is prepared to assess and respond to emergency events acceptably.

Based on these findings, the NRC staff concludes that the licensee can continue to operate its AGN-201M research reactor in accordance with its application, without endangering the health and safety of their staff, the public and the environment.

1.3 History

The research reactor was originally designed and constructed for research and teaching in the field of radio-analytical chemistry and for other assigned tasks. The Construction Permit (CPRR-121) was issued on December 23, 1975, and the operating license was issued on April 28, 1976. The initial licensed authorized operations up to 0.1 watts(t). The authorized licensed power limit was increased to 5 watts(t) by license amendment 2, issued August 30, 1979.

1.4 Reactor Description

The ISU AGN-201M is a solid homogeneous core research reactor. The core is contained within a graphite reflector, which in turn is within the core tank. This tank is then surrounded by 10 cm of lead shielding (gamma reduction) and a water tank containing 55 cm of water (fast neutron shield). The reactor tank is surrounded by a biological shielding wall constructed of dense (10 cm × 20 cm × 40 cm) concrete blocks, and (10 cm × 20 cm × 30.5 cm) barytes concrete blocks.

The fuel design is similar to that used by other NRC-licensed AGN-201M reactors. Specifically, it consists of sintered uranium dioxide pellets, homogeneously mixed with polyethylene pellets, compressed into cylinders. These cylinders have holes to accommodate control rods and a fuse, and

are stacked vertically to attain a critical loading. The uranium enrichment is less than 20% in the U^{235} isotope. The reactor exhibits a large prompt negative temperature coefficient, which is typical of UO_2 sintered fuel. Four control rods, consisting of the exact same composition as the fuel, control reactivity. In addition, the facility has an extra shutdown mechanism, of placing a cadmium rod in the glory hole, an access port in the side of the reactor.

1.5 Facilities and Equipment

This general description from SAR Chapter 4.0, "AGN-201 Reactor" is consistent with the design as previously licensed by the NRC and operated by the licensee.

1.6 Comparison with Similar Facilities

The ISU AGN-201M research reactor facility is similar to other research reactors licensed to operate by the NRC. The NRC licenses two other AGN-201M research reactors that use fuel similar or identical to that of ISU. Both of these AGN-201M research reactors are licensed for a maximum power level approximately equal to that at ISU. The NRC licenses research reactors at about 27 other nonprofit educational institutions. Of these nonprofit educational institutions, three are AGN-201 reactors. All of these reactors are sited in multipurpose educational building situations similar to that at ISU.

1.7 Nuclear Waste Policy Act of 1982

Section 302(b)(1)(B) of the Nuclear Waste Policy Act of 1982 specifies that the NRC may require, as a precondition to issuing or renewing an operating license for a research or test reactor, that the licensee will have entered an agreement with the U.S. Department of Energy (DOE) for the disposal of high-level radioactive wastes and spent nuclear fuel. In a letter dated May 3, 1983, R. L. Morgan, DOE, informed H. Denton, NRC, that DOE had determined that universities and other government agencies operating non-power reactors have entered into contracts with DOE, providing that DOE retains title to the fuel and is obligated to take the spent fuel and/or high-level waste for storage or reprocessing.

1.8 Conclusions

The NRC staff concludes as follows:

- The design bases and safety considerations of the facility are consistent with similar research and test reactors in fuel type, thermal power level, and siting considerations. The NRC's inspection history of this facility shows consistently safe operation.
- The licensee's design does not differ in any substantive way from similar facilities that have been found acceptable by the NRC.
- The licensee has used data and operational experience from similar reactor facilities, including its own, to provide reasonable assurance that the facility can operate safely as designed.

2 SITE CHARACTERISTICS

2.1 Geography and Demography

The ISU AGN-201M research reactor is located on the ISU campus property. It is in the city of Pocatello, within Bannock County, in the southeast corner of the State of Idaho. The research reactor is in the Lillibridge Engineering Laboratory. The building has research and teaching laboratories, lecture halls, classrooms, offices and workshops. The building is surrounded by similar facilities.

Estimated population of Pocatello was about 50,000 in 1992. The population within one mile of the College of engineering was estimated to be about 10,430 in 1994. The closest dwelling to the reactor is about 300 feet (91 meters) to the north.

Daytime population on the campus is about 1,200 faculty and staff, and 12,000 students. At other times, the population on campus is substantially below these values.

2.2 Nearby Industrial, Transportation, and Government Facilities

2.2.1 Industry

There is limited industry within a 5 mile (8 km) radius of the reactor site. The area surrounding the campus is primarily residential, with small businesses and shops that cater to the student population. One major industrial employer in the Pocatello area is a Phosphate rock processing company located 7.2 km (4-½ miles) from the facility.

2.2.2 Transportation

The major north-south highway, Interstate 15 (I-15), passes to the east of the city. An intersection of I-15 with Interstate 86 (I-86) is located just north of the city. The Pocatello Municipal Airport is about 11.3 km (7 miles) northwest of campus on I-86. The nearest railroad line is approximately 0.8 km (½ mile) west of the facility.

2.2.3 Government Facilities

The closest military installation is Hill Air Force Base located about 193 km (120 miles) south of Pocatello. DOE's Idaho National Engineering and Environmental Laboratory located about 80 km (50 miles) northwest of Pocatello.

2.2.4 Conclusion

Based on experience and the distances and lack of potential impact on the reactor, the NRC staff does not expect local industry, transportation or government facilities to impact future operations of the research reactor.

2.3 Meteorology

Section 2.3 of the SAR shows that due to its position, a high plateau surrounded by mountains, climate extremes are rare. There is a small occurrence of tornadoes in the area, but well below the national average. Windstorms are more frequent but the average high wind speed is approximately 60 mph. Because of its position (high plateau surrounded by mountains, rain storms are rare. This data confirms that there is a low possibility that weather related hazards would affect the facility.

2.4 Geology and Seismology

2.4.1 Site Geology

In SAR section 2.4.3 the licensee referenced research reactor site test borings. These borings in addition to the reference material in SAR section 2.4, "Geology," confirmed a stable, well-founded site geology.

2.4.2 Seismology

Official hazard maps show the environs near the reactor to be a low hazard area.

2.5 Hydrology

SAR section 2.5 shows the research reactor site is not subject to flooding potential. The NRC staff confirmed this through a thorough review of the material referenced in the SAR.

2.6 Conclusions

The NRC staff concludes as follows:

- The licensee has provided sufficient information to accurately describe the geography and demography surrounding the research reactor and the information is sufficient to assess the radiological impact resulting from the location and operation of the reactor. There is reasonable assurance that no geographic or demographic features will render the site unsuitable for continued operation of the reactor.
- The licensee has discussed or shown nearby manmade facilities and activities (i.e., industrial, transportation, and military) that have a potential to pose a hazard to reactor operations. There is reasonable assurance that operation of these facilities will not affect reactor operation.
- Meteorological history and projections were factored into the design of the reactor building, such that no weather-related event is likely to cause damage to the reactor and a release of radioactive material. The meteorological information is sufficient to evaluate dispersion calculations conservatively and calculate the consequences of releases from routine operations or postulated accidents.
- ISU provided information on the geology and hydrology of the ISU site in sufficient detail to provide a reasonable assurance that none of the described site characteristics will affect the design bases for structures, systems, and operating characteristics of the reactor.
- Information in the ISU SAR shows that damaging seismic activity at the reactor site during the term of the license is very unlikely. Considering the facility design, if seismic damage to the building was to occur, radiological consequences would be bounded as analyzed in Chapter 13 of the SAR. The ISU SAR shows that there is no significant likelihood that the licensee's staff, the public and the environment would be subject to undue radiological risk due to seismic activity; therefore, the site remains suitable for the research reactor.

3 STRUCTURE, SYSTEM, AND COMPONENT DESIGN

3.1 Reactor Facility Description

The Lillibridge Engineering Laboratory contains laboratories, classrooms, offices and a large workshop. A single story Mechanical shop and experimental fluids research area is located at the northern end of the building. Two areas within the shop are used in the case of reactor emergencies. The Nuclear Operations Area includes the Reactor Lab, a Subcritical Assembly Lab, a Radiation Counting Lab, an observation/classroom and the Reactor Supervisor's office as discussed in SAR Chapter 3.

3.1.1 Reactor Laboratory

Earth shields the Reactor Laboratory room up to a height of 10 feet from the floor. The reactor is located behind an L-shaped shield wall. The control console for the reactor is located just outside of the shield wall. Access to the reactor lab covered in both the SAR and the Physical Security Plan has been reviewed and found to be adequate for routine, emergency and security purposes.

The reactor laboratory is supplied with 120 VAC and 240 VAC power and phone lines from the Lillibridge Engineering Laboratory building. The reactor laboratory is NOT supplied with any plumbing. The room contains a full height observation window, between the lab and the reactor observation room.

3.1.2 Reactor Observation Room

This room is located next to the reactor laboratory, and one wall contains a full height window looking into the reactor laboratory. The room is normally kept locked because the room is a radiation area when the reactor is operating at full power. Access to the room is restricted to authorized personnel.

3.1.3 Radiation Counting Laboratory

This room contains a small fume hood, along with associated compressed air, plumbing, etc. Primary equipment in the room consists of a liquid nitrogen cooled germanium detector based spectroscopy system. The room contains the outboard terminus of a pneumatic tube system, connected to the reactor, along with associated counting system. This room also contains small sealed radiation sources.

3.2 Wind and Water Damage

As summarized in Section 2.3, Pocatello experiences few extreme wind conditions mostly comprising wind storms. There are few recorded instances of tornadoes in the Pocatello area, and no record of tropical storms. As summarized in Section 2.6, the ISU campus is located above both the highest recorded flood plain and the water table in the Pocatello area. The likelihood of damage to the reactor due to either severe wind or flooding is very low. In addition, the design of the AGN-201M reactor is such that even if it were to float away on a flood, the self-contained reactor would withstand this emergency.

3.3 Seismically Induced Reactor Damage

As summarized in Section 2.4, the Pocatello area has a relatively low risk of experiencing a severe seismic event. In the event of an earthquake causing catastrophic damage to the reactor laboratory, the reactor could be damaged and a small fraction of the fission product activity released. However, because of the low intensities of seismic events, design of the reactor, and low fission product inventory, the risk to the public resulting from any seismic-induced damage to the reactor facility would be insignificant.

3.4 Electro-Mechanical Systems and Components

The fueled control rods enter from the bottom of the reactor structure. The motors, electromagnets, gear boxes, switches, and wiring are all below the tank and are readily accessible for visual inspection, testing, and maintenance. The licensee has a preventive maintenance and surveillance program in place to provide reasonable assurance that all mechanical systems and components important to safety meet the performance requirements of the TSs.

3.5 Conclusions

The staff concludes that the design bases and operation since original licensing of the facility structures, systems and components give reasonable assurance that they will function as designed to ensure continued safe operation and safe shutdown of the reactor, for any credible and likely wind water and seismic damage associated with the site.

The staff also concludes that surveillance activities proposed in the TSs continue to acceptably ensure that the safety-related functions of the facility structures, systems and components will be operable and that the health and safety of the licensee's staff, the public and the environment will be protected.

4 REACTOR

4.1 Introduction

The ISU AGN-201M reactor is essentially identical to the other AGN-201 reactors which have operated around the world since the 1950s. This design is a small homogenous thermal reactor regularly used for operations training and student laboratory experiments at thermal power levels of 5 watts or less. The reactor uses polyethylene as the moderator, and is surrounded by a graphite neutron reflector, which in turn is surrounded by lead and water shielding, all located in a stainless-steel tank. Due to the low power level, there is no need for a coolant. Reactor control is achieved by inserting or withdrawing four fuel/moderator or moderator only control rods from the bottom of the core.

4.2 Reactor Core

The ISU AGN-201M reactor core (Figure 4.1) is a right cylinder measuring 25.6 cm in diameter, and 24 cm high. The core consists of nine separate fuel-moderator disks containing particles of UO_2 (enriched up to 20% U^{235}) and particles of polyethylene. The core is contained in a gas-tight aluminum cylindrical tank (32.2 cm in diameter, 76 cm high).

4.3 Reflector

A graphite neutron reflector surrounds the core. The graphite has a radial thickness of about 20 cm, with a density of 1.75 g/cm^3 . Some of the graphite is located within the core tank, with the remainder outside. Four access holes (through tubes used for experiments) pass through the graphite reflector and water to the exterior wall of the water tank.

4.4 Shielding

Radiation shielding is accomplished by three layers of materials, lead and water within the reactor tank, and concrete external to the tank. The first layer of shielding is a 10 cm inch can surrounding the graphite reflector. The core, graphite reflector and lead shielding are all contained in a thick steel reactor tank. The reactor tank acts as a secondary containment for the core tank and is fluid tight. A water tank (198 cm in diameter) is the third and outermost of the fluid tight containers. This tank is also stainless-steel and holds about 3800 liters of water to create the fast neutron shield. The entire assembly is in turn surrounded by concrete shielding which was added to supply additional shielding to allow raising the reactor license limit from 100 milliwatts (t) to 5 watts (t). There is no concrete shielding above the reactor core.

4.5 Control Rods and Drives

The ISU research reactor has four control rods, two safety rods, one coarse control rod and one fine control rod. Criticality may only be achieved with the addition of the fuel-moderator contained in the safety and control rods. The safety and coarse control rods are magnetically coupled to a carriage and compress a spring as they enter the core from the bottom. Thus on a scram signal, which de-energizes the electromagnet, causes these rods to be ejected out the bottom of the core by gravity assisted by the springs to the full out position. The fine control rod must be driven out of the reactor because it is mechanically coupled to its carriage.

4.5.1 Safety Rods

The two safety rods are identical. Each is 5 cm in diameter with an active length of 15 cm. The active fuel portion is identical to the mixture contained in the fuel-moderator disks, and is doubly encapsulated in aluminum containers. Each rod has a total travel length of 24 cm and the time to fully insert the rods is between 40 and 50 seconds. The scram removal time is approximately 200 milliseconds, from the time the rod starts exiting the core. Each rod is worth approximately 1.25% $\Delta K/K$.

4.5.2 Coarse Control Rod

The coarse control rod is 5 cm in diameter with an active length of 15 cm. The active fuel portion is identical to the mixture contained in the fuel-moderator disks, and is doubly encapsulated in aluminum containers. The coarse control rod has a total travel length of 24 cm and has two insertion speeds high ($\approx 1/2$ cm/sec) or low ($\approx 1/4$ cm/sec). At high speed, the time to fully insert the rod is between 40 and 50 seconds. The scram removal time is approximately 200 milliseconds, from the time the rod starts exiting the core. The rod is worth approximately 1.25% $\Delta K/K$.

4.5.3 Fine Control Rod

The fine control rod is 2.5 cm in diameter with an active length of 15 cm. The active portion may be identical to the mixture contained in the fuel-moderator disks, or may be polyethylene only. It is doubly encapsulated in aluminum containers. The fine control rod has a total travel length of 24 cm and has two insertion speeds high ($\approx 1/2$ cm/sec) or low ($\approx 1/4$ cm/sec). At high speed the time to fully insert the rod is between 40 and 50 seconds. On a scram the fine control rod does not decouple magnetically, but is driven out at the fast withdrawal rate. The rod is worth approximately 0.31% $\Delta K/K$, if made of fuel material, and approximately 0.155% $\Delta K/K$ if made of polyethylene only.

4.6 Dynamic Design Evaluation

4.6.1 Reactor Physics and Reactivity Control

The ISU AGN-201 reactor is operated by manipulating control rods in response to observed changes in measured reactor parameters (neutron flux). Interlocks prevent inadvertent reactivity additions and a scram system initiates a rapid automatic shutdown when trip set points are reached. The design of the fuel-moderator has an inherently strong negative reactivity feedback ($-2.5 \times 10^{-4}/^{\circ}\text{C}$) as a result of rapid core expansion. This negative feedback enhances stability and safety and is effective even if control rods or safety instrumentation fail to perform their intended functions.

4.6.2 Shutdown Margin, Excess Reactivity, and Experiment Reactivity Worth

Technical Specification (TS) 3.1(a) limits the available excess reactivity with all control and safety rods fully inserted and including the potential reactivity worth of all experiments to 0.65% $\Delta k/k$ ($\$0.878$) referenced to 20°C. This limitation ensures that the reactor will not go prompt critical, and that reactor periods would be of sufficient length as to allow the reactor protection system and/or operator to shutdown the reactor before any safety limit would be reached.

TS 3.1(b) limits the shutdown margin with both the most reactive safety or control rod and the fine control rod fully inserted to a minimum of 1% $\Delta k/k$ ($\$1.35$). TS 3.2.b limits the average reactivity addition rate for each control or safety rod to a maximum of 0.065% $\Delta k/k$ per second ($\$0.00877$ per second). The shutdown margin and reactivity addition limitations ensure that the reactor would be subcritical even if the highest worth rod failed in the fully inserted position upon receipt of a scram signal.

4.7 Conclusions

The NRC staff concludes that the ISU AGN-201M is designed and built according to good industrial practices. The reactor consists of standardized components representing many reactor-years of operation, and it includes both diverse and redundant safety related systems.

The staff's review of the reactor facility included studying its design, installation and operation limitations based on its original and proposed Technical Specifications, facility prepared Safety Analysis Report, and other pertinent documents. The design features are similar to other AGN-201M research reactors licensed by the NRC. The fuel, low enriched scintered UO_2 in a polyethylene matrix is the same as the fuel used by the other two AGN-201M reactors. A review of the operating experience of the ISU reactor since 1976, and the operation of AGN-201M reactors in general since the 1950s, has shown that they have all performed safely. The NRC staff concludes that based on all of these factors there is reasonable assurance that the reactor can continue to operate safely, as limited by its proposed Technical Specifications for the proposed duration of the license.

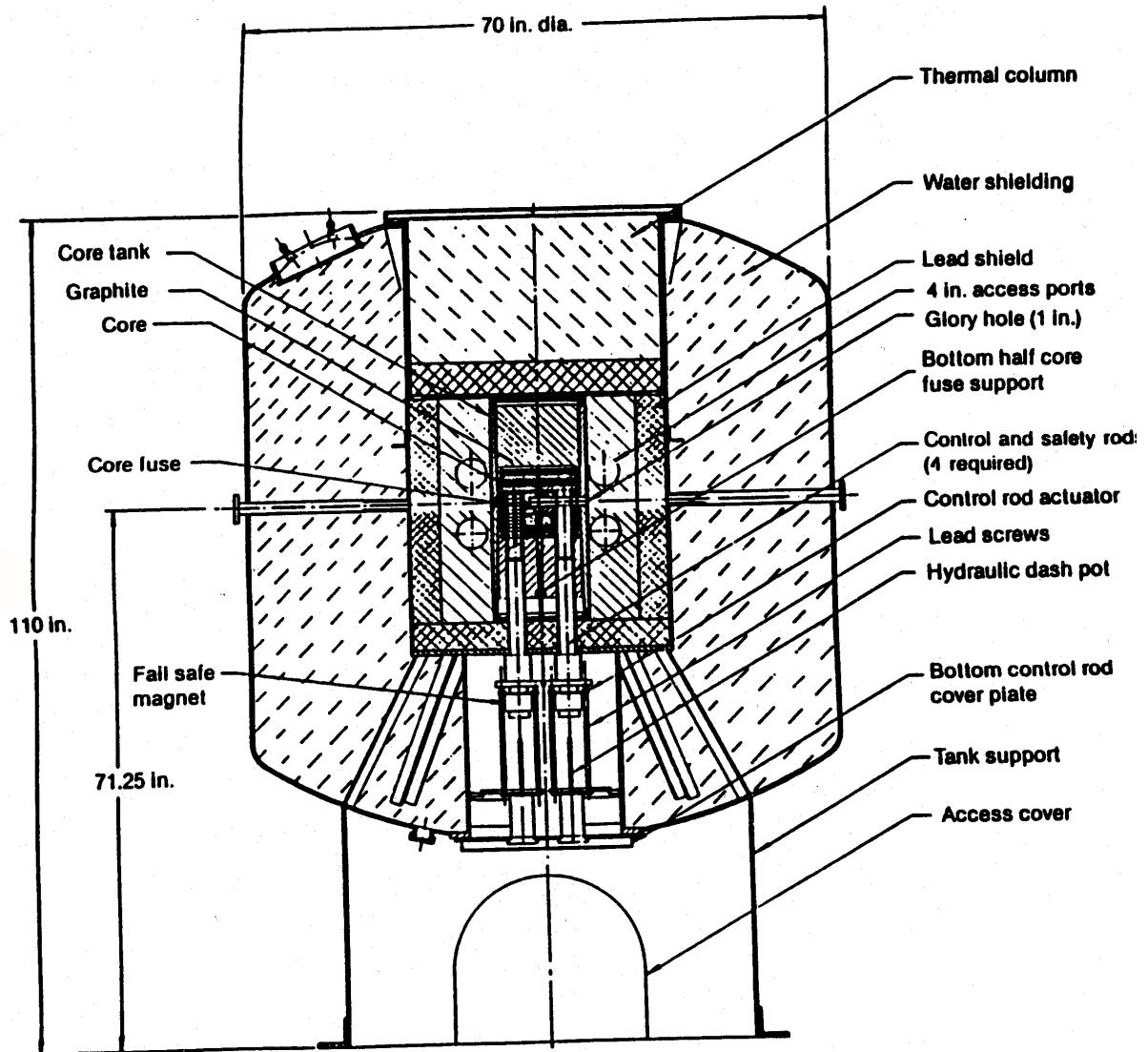

Figure 4.1 Reactor Core

Table 4.1 Principal Design Parameters

Parameter	Description
Reactor Type	AGN-201
Maximum Licensed Power Level	5 watts(thermal)
Fuel Element Design	
Fuel-moderator material	UO ₂ -polyethelyene
Uranium Content	6 wt. %
Uranium Enrichment	< 20% U ²³⁵
Shape	Disk
Thickness of Fuel	Varying from 1 to 4 cm
Diameter of Fuel	25.6 cm
Number of fuel disks	9
Source type	Ra-Be (10 mg RaCl ₂ mixed with Be powder)
Excess Reactivity:	0.65% $\Delta K/K$ (maximum)
Control Rods:	
Coarse control rod	1
Fine control rod	1
Safety rods	2
Total reactivity worth or rods	$\approx 4\% \Delta K/K$
Reactor cooling	Natural convection of tank water
β_{eff}	0.0075

5 REACTOR COOLING SYSTEM

AGN-201M reactors operate at very low power levels (5 watts(thermal) maximum), for short periods of time. For this reason, these reactors do not require an active coolant system. The little heat generated by this type of reactor is easily transferred to the environment by natural circulation of the fast neutron shielding water in the reactor tank. In addition, operation at 5 watts will not cause the temperature of this water to rise.

The staff concludes that by design this reactor does not require any type of coolant system to remove heat generated either by operation of the reactor or by fission product decay.

6 ENGINEERED SAFETY FEATURES

Engineered Safety Feature (ESF) systems are systems designed to mitigate the radiological consequences of design-basis accidents. The reactor has a maximum licensed power level is 5 watts (thermal) resulting in a very low fission product inventory. Additionally, the accident analyses contained in Section 14 of this document, and Section 14 of the facility submitted Safety Analysis Report, indicate that no accident (including the maximum hypothetical) will cause the release of significant amounts of radiological contaminants. Based on these assumptions the licensee has determined that the ISU reactor facility does not require any ESF systems.

The NRC staff concludes that operation of the ISU AGN-201M reactor without any ESF systems does not pose any significant health and safety hazards to the public or to the environment in the event of an accident.

7 INSTRUMENTATION AND CONTROL

7.1 Instrumentation System

Instrumentation and control (I&C) systems comprise the sensors, electronic circuitry, displays, and actuating devices that provide the information and the means to safely control the reactor and to avoid or mitigate accidents. The I&C systems in use at the ISU AGN-201M reactor are similar, in general, to those used at other U.S. research reactors of a similar size.

Table 7.1 Reactor Control and Safety Channels
(Note all setpoints and scrams are per TS 3.2.a through j except as noted.)

Device	Action	Set points
Nuclear Safety Channel #1 (Startup Count Rate Channel)	Low Power Scram ¹ High Power Scram ²	5% of full scale ¹ 10 watts(thermal) ²
Nuclear Safety Channel #2 (Log Power Channel)	Low Power Scram High Power Scram Short Reactor Period Scram	3×10^{-13} amp 10 watts(thermal) 5 seconds
Nuclear Safety Channel #3 (Linear Power Channel)	Low Power Scram High Power Scram	5% of full scale 10 watts(thermal)
Tank water level interlock	Lose of shielding Scram	25.4 cm below highest point on the reactor shield tank manhole opening
Tank water temperature interlock	Reactivity addition limit Scram	15°C or greater
Seismic displacement interlock	Seismic protection Scram	Horizontal amplitude > 0.159 cm
Area Radiation Monitor	Radiation protection Alarm	≤ 10 mR/hr
Console electricity loss	Normal Shutdown Scram	Loss of electrical power
Manual Scram	Normal Shutdown Scram	Scram on operator decision

¹ May be bypassed with Reactor Supervisor permission whenever either the reactor control or safety rods are not in their fully withdrawn position
² Not required by TS

7.1.1 Nuclear Instrumentation

The Nuclear Instrumentation used at the ISU AGN-201M reactor consists of three channels. Nuclear Safety Channel #1 uses a BF_3 proportional counter to detect very low levels of neutrons within the core. The primary safety function associated with channel #1 is to provide a trip mechanism at low power levels to preclude reactor startup with an insufficient neutron population. In addition, channel #1 supplies a high power trip which is NOT required by technical specifications. The neutron detector is mounted on a buoyant tube which is held down by a solenoid arm during reactor startup. At higher power levels, greater than 0.1 watt, the operator activates the solenoid switch allowing the detector to float up to a fixed position. This along with a partial cadmium jacket, allow the source range detector to operate over the entire range of reactor power.

Nuclear Safety Channel #2 uses a BF_3 filled ionization chamber to detect reactor flux. The output of the detector is fed to a logarithmic micro-ammeter covering the range from 10^{-13} to 10^{-6} amps without range switching. In addition this channel feeds a period circuit, which displays from infinity to 3 seconds. The primary safety function associated with channel #2 is to provide a trip mechanism at low power levels and high power levels. In addition, channel #2 supplies a low period trip. All three of these scrams are required by technical specifications. The output from channel # 2, feeds a strip recorder on the reactor console.

Nuclear Safety Channel #3 uses a BF_3 filled ionization chamber to detect reactor flux. The output of the detector is fed to a linear micro-ammeter covering the range from 3×10^{-13} to 10^{-3} amperes, with a linear readout. This is accomplished using a range switch. The primary safety function associated with channel #3 is to provide a trip mechanism at low power levels and high power levels, for each switched range. The output from channel # 2, feeds a strip recorder on the reactor console.

7.1.2 Process Instrumentation

The reactor also has numerous process instrument scrams. When a predetermined condition is reached, these circuits will break the continuity of the interlock circuit causing a reactor scram. The process scrams are: shielding water level, shielding water temperature, earthquake, sensitrol relay, reset buttons, and control rod connector plugs.

A sensitrol relay is actually a sensing device with two relays, one high and one low. The lower relay is normally closed and the higher is normally open. The sensitrol relays in the control console are designed to be open when reactor power is greater than 5% and less than 90%. When reactor power is less than five percent, the lower relay will close, and when reactor power is greater than 90%, the upper relay will close. The closing of either relay will cause a scram.

The shielding water level switch is a water-tight micro-switch and an actuator connected to a float. If the shielding water decreases to a pre-determined minimum level, the micro-switch will break the interlock circuit. The shielding water also contains a simple bimetallic thermal switch. If the temperature of the shielding water decreases to a predetermined level (calibrated for 15°C), the bimetallic strip will bend, breaking the interlock circuit. Finally an earthquake detector consists of a steel ball mounted on two terminal strips. If the reactor receives a physical shock of sufficient size, the ball will move relative to the two terminal strips breaking the interlock circuit.

In addition to the above, to insure that no instrumentation may be made inoperative during reactor operation, all reset buttons and cable connectors are included in the interlock circuit. Holding down any reset button or any improperly connected cable connector to the safety and controls rods will open the interlock circuit.

Finally, the facility has a fixed radiation area monitor in the reactor console. This system is reviewed and evaluated in chapter 11 of this SER.

7.2 Nuclear Control System

The control console is a desk-type with controls or indications for control rod drives, facility interlocks, neutron detectors, remote area radiation monitoring and other alarms. Control console power is provided through the "MAIN" switch located in the lower left cabinet section of the control console desk. Instruments and components are provided to monitor, indicate, record and control neutron flux density, and radiation intensities in the area near the reactor console. A detailed description of the nuclear control system is presented in Section 4.5 of this SER.

7.3 Conclusions

Redundancy in the important ranges of power measurement is ensured by overlapping ranges of the source, log, and linear channels. All important nuclear and process variables are monitored and/or displayed on the control console.

The NRC staff concludes that the I&C systems at the ISU AGN-201M reactor are well designed and maintained.

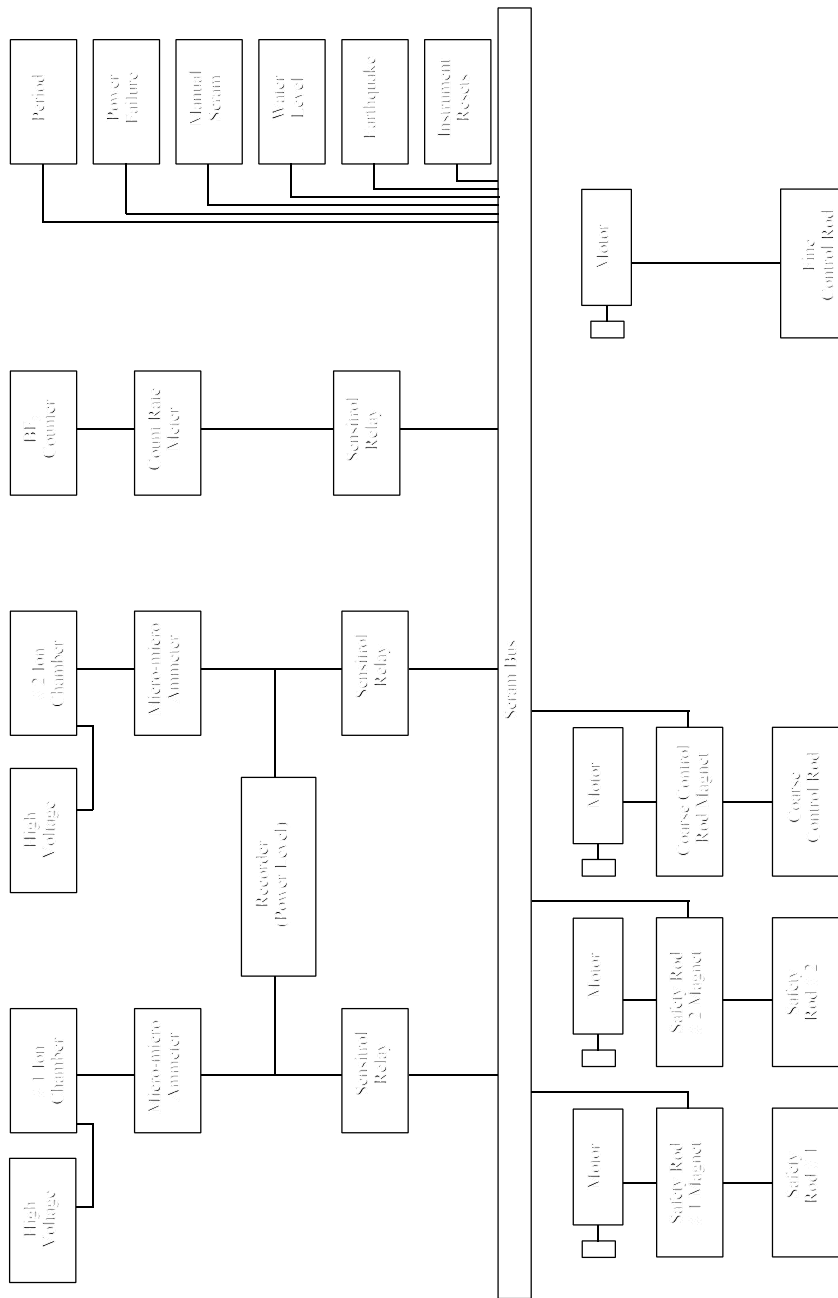

AGN-201M Control System

Figure 7.1 Control System

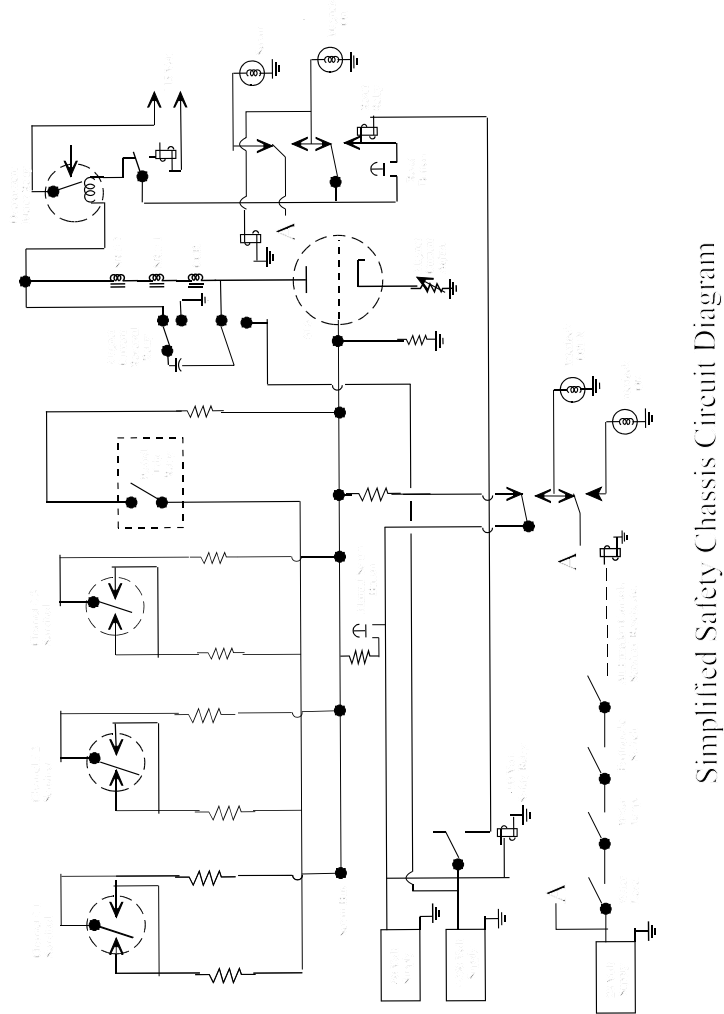

Simplified Safety Chassis Circuit Diagram

Figure 7.2 Simplified Safety Chassis Circuit Diagram

8 ELECTRICAL POWER

8.1 Normal Electrical Power System

The routine electric power requirements for the ISU AGN-201M reactor are 2 kilowatts of 110 VAC, single phase, at a frequency of 60 hertz. The reactor room receives 110 VAC, 240 VAC and lighting from the Lillibridge Engineering Laboratory power which in turn is supplied by with 110, 240 and 480 VAC power from the campus system. The cabinet within the left pedestal of the control console contains the “main” breaker for console power.

8.2 Emergency Electrical Power System

The AGN-201M reactor design does not require the use of emergency electrical power for either reactor operation, or the removal of decay heat generated following an accident. The control system is designed to be fail-safe by causing the reactor to scram on a loss of electrical power. In the case of a loss of electrical power, emergency lights powered by battery, will operate automatically, and battery powered portable radiation monitoring instruments are located at the console.

8.3 Conclusions

The electrical power system associated with the ISU reactor is similar to those at other low-power research reactor facilities. This, coupled with the fact that the reactor will scram automatically on a power failure, supports the staff's conclusion that the normal electrical power system supplemented by battery powered emergency lights and portable radiation instruments is acceptable for continued safe operation of the ISU AGN-201M reactor.

9 AUXILIARY SYSTEMS

9.1 Fuel Storage and Handling

Because of the low power level of the AGN-201M reactor, refueling is not necessary, even after 40 years operation. The normal fuel storage is in the reactor core, except for one laboratory experiment, (approach to critical). During that experiment, a clean area is set up on the reactor top and the tank is vented (through filters). The reactor core reactivity for this experiment is altered by the removal and replacement of the top five fuel element disks. This experiment is done under the supervision of both ISU reactor and radiological management. Protective clothing is worn when handling fuel.

The only other fuel associated with the reactor laboratory is the fuel used for a subcritical assembly (sigma pile), which is kept in an approved storage facility.

9.2 Fire Protection System

The components of the AGN-201M reactor are basically nonflammable, as is the building in which it is housed. No special precautions regarding the reactor are required in the event of a fire. A carbon-dioxide (CO₂) extinguisher is located on the east wall of the reactor room along with a pull station connected to the Lillibridge Engineering Laboratory Fire Alarm System. Facility procedures require the console operator to shutdown the reactor and take the key and notify facility management. Existing fire procedures eliminate accumulation of flammable material in the building reducing the probability of a fire.

9.3 Communications System

The reactor room is serviced by the University's phone system, which allows communication to and from outside sources.

9.4 Ventilation System

The Lillibridge Engineering Laboratory has a dedicated ventilation system which uses 20% new air with 80% recirculated air. Air from the reactor laboratory mixes with air in the Lillibridge Engineering Laboratory ventilation system in the ratio of 1:27 respectively. In the case of an emergency, the ventilation system fans may be turned off to reduce emission and recirculation of any airborne radioactive contamination.

9.5 Conclusions

The fuel handling and storage system designs are adequate to ensure that fuel may be moved, serviced, and stored without danger to operating personnel, or the public due to radioactivity of accidental criticality event.

The communication systems are adequate to ensure sufficient warning can be given of abnormal and emergency events and that appropriate communications may be conducted.

The fire protection provisions and systems are consistent with similar provisions at NRC licensed research and test reactor facilities that contain very little flammable material in the reactor bay.

Based on the above findings, the NRC staff concludes that the ISU auxiliary systems provide the necessary services to the reactor facility for the requested license period.

10 EXPERIMENTAL FACILITIES

The ISU AGN-201M research reactor serves as a source of ionizing and neutron radiation for research, education and radio-nuclide production. Experimental facilities include a *'glory hole'*, four access ports, a thermal column tank, and a removable pneumatic tube transfer system. Technical specifications limit the effect of reactivity of all experiments and provide means for technical and safety review.

10.1 Glory Hole

The reactor is equipped with a glory hole for conducting experiments or irradiating small samples in the core. The glory hole is a 2.22 cm ($\frac{7}{8}$ inch) diameter hole passing through the center of the core at the core median plane. The tube is constructed so samples are irradiated at the core center-line.

10.2 Access Ports

The reactor is equipped with four access ports. These ports are four 10 cm (4 inch) through tubes tangential to the core passing through the graphite reflector.

10.3 Thermal Column

The thermal column consists of a tank above the core, which may be filled with water (normal configuration for shielding), or filled with graphite (to convert the tank to a thermal column facility).

10.4 Pneumatic Tube System (Rabbit)

The pneumatic transfer system allows small sealed samples to be transported rapidly between the core and a laboratory adjacent to the reactor room. These experimental facilities permit studies involving short-lived isotopes. The system uses compressed N₂ to move samples into and out of the core. This system is not covered in the Safety Analysis Report, therefore more detail will be covered in the next paragraph.

The pneumatic transfer tube system is not normally installed. When an experimenter wishes to use the system, it must be installed per Experimental Plan No. 19. The system consists of polyethylene tubing with an inner diameter of 0.625 or $\frac{5}{8}$ inch (1.59 cm), with one terminus in the counting laboratory, and the other inserted into the glory hole. The sample holder (rabbit) is also made of polyethylene, and has a diameter of not more than 1.33 cm (0.524 inch). The system is completely manual. Samples are inserted and removed from the reactor by the manual opening and closing of valves, applying N₂ gas to the system.

10.5 Limits, Reviews, and Conduct of Experiments

TS 3.1.a requires the available excess reactivity with all control and safety rods fully inserted and including the potential reactivity worth of all experiments shall not exceed 0.65% $\Delta k/k$ ($\$0.878$) referenced to 20°C. TS 3.3.a requires experiments containing materials corrosive to reactor components or which contain liquid or gaseous, fissionable materials shall be doubly encapsulated. TS 3.3.b prohibits explosive materials from being inserted into experimental facilities or the reactor or stored within the confines of the reactor facility.

TS 3.3.c requires that the radioactive material content, including fission products of any experiment shall be limited so that the complete release of all gaseous, particulate, or volatile components from the experiment will not result in:

- (1) A total effective dose equivalent to any person occupying an unrestricted area continuously for a period of two hours starting at the time of release in excess of 0.1 Sv (10 mrem) as a result of any airborne pathway, or
- (2) A total effective dose equivalent to any person occupying an unrestricted area continuously for a period of two hours starting at the time of release in excess of 1 mSv (100 mrem) as a result of all pathways, or
- (3) A total effective dose equivalent to any radiation worker occupying a restricted area during the length of time required to evacuate the restricted area in excess of 50 mSv (5 rem).

TS 6.1.3 requires the Reactor Administrator to seek the advice and approval of the Radiation Safety Committee and/or the Reactor Safety Committee in all matters concerning new experiments, new procedures, and facility modifications which might affect safety.

TS 6.1.4 requires the Reactor Supervisor to authorize all experiments, procedures, and changes thereto which have received the approval of the Reactor Safety Committee and/or the Radiation Safety Committee and the Reactor Administrator; and be responsible for the preparation of experimental procedures involving the use of the reactor.

TS 6.1.8 requires the Reactor Safety Committee to ... review and approve all proposed experiments and procedures and changes thereto; ... to determine whether proposed experiments, procedures, or modifications require a license amendment per the requirements of 10 CFR 50.59(c)(2)(i) through (viii), and are in accordance with these Technical Specifications ...

TS 6.1.10 requires the Radiation Safety Officer to review and approve all procedures and experiments involving radiological safety.

TS 6.7.a requires the reactor administrator and the reactor safety committee to review and approve an experimental procedure prepared by the reactor supervisor prior to initiating any new reactor experiment.

TS 6.7.b requires that approved experiments must be performed under the cognizance of the Reactor Supervisor.

10.6 Conclusion

The ISU staff has established adequate reactor experimental facilities, combined with detailed review and administrative procedures applied to research activities, to ensure that experiments are unlikely to fail, release significant radioactivity to the environment, or cause damage to reactor systems or its fuel. The NRC staff concludes that there is reasonable assurance that the experimental programs and facilities do not pose a significant risk to the health and safety of the public.

11 RADIATION PROTECTION AND WASTE MANAGEMENT PROGRAM

11.1 Radiation Protection Program

ISU has a structured radiation protection program with a health physics staff equipped with radiation detection equipment to determine, control and document occupational radiation exposures at all university facilities. ISU has assigned the Vice President for Academic Affairs as the Senior Management representative for Radiation Protection at the University. As part of his duties, the Vice President for Academic Affairs has appointed a Radiation Safety Committee (RSC) and a Radiation Safety Officer (RSO). Figure 11.1 is a chart of the ISU management chain with regard to Radiation Protection.

The RSC is responsible for promulgating policies, rules and procedures for the safe use of radiation sources and materials at the university. The RSO is responsible for assisting the RSC in the performance of its duties. Both the RSC and the RSO report directly to the Vice President for Academic Affairs. Per the ISU Radiation Safety Policy Manual, the Vice President for Academic Affairs is required to meet with the RSC and the RSO a minimum of once a year to discuss the university's radiation safety program. In addition, the Vice President for Academic Affairs is a voting ex-officio member of the RSC, and is expected to attend at least one RSC meeting per year.

11.1.1 ALARA Commitment

The ISU RSC has prepared a Radiation Safety Policy Manual implementing the basic principle that all radiation doses are to be kept "As Low As Reasonably Achievable (ALARA)". Per the ISU Radiation Safety Policy Manual, the ALARA principle is applicable even when the potential dose is well below any prescribed limits.

11.1.2 Health Physics Staffing

The Radiation Safety Division of the Technical Safety Office (TSO) is the organizational entity that provides the administrative and technical services in support of the ISU radiation protection program. The Radiation Safety Office is located in room 101A of the Physical Science Building, which is located next to the Lillibridge Engineering Laboratory.

The ISU Radiation Safety Policy Manual defines five levels of radiation workers. 1. Responsible User, 2. Radiation User, 3. Badged Personnel, 4. Minimally exposed personnel and 5. Potentially exposed personnel. A Responsible User is "an individual authorized by the Radiation Safety Committee to acquire and use specific radiation sources, and to supervise such use by others." Both the Reactor Administrator and the Reactor Supervisor are designated as "Responsible Users" for the AGN-201M reactor. All other personnel associated with the reactor are classified as Radiation Users which includes both badged personnel and minimally exposed personnel. Typically either the Reactor Administrator or the Reactor Supervisor is designated as the Responsible User for the ISU AGN-201M reactor facility.

11.1.3 Health Physics Procedures

The University has prepared written procedures addressing health physics activities governing different aspects of the control of exposure due to radioactive sources, contamination, and waste. These procedures formalize the relationships between the health physics staff (TSO) and the persons both operating and using the reactor for experimental purposes. These procedures specify administrative limits, action points, and appropriate responses regarding radiological controls. Copies of these procedures are readily available to the operational staff, as well as the health physics and administrative personnel.

11.1.4 Health Physics Training

All ISU reactor facility personnel must receive training in radiation safety prior to assuming their work responsibilities. The training for responsible users must be evaluated by either the RSO or the RSO's Staff. The responsible user is required to ensure that subordinates and students working in their facilities are trained. All training must meet the requirements outlined in the ISU Radiation Safety Policy Manual. In addition, all responsible users and radiation users must attend annual refresher training, which covers any new local or NRC requirements, problems encountered over the past year, discussion of exposure reports, and an overview of radiation safety basics.

11.1.5 Radiation Sources

The primary source of radiation at the ISU AGN-201M reactor facility is the reactor itself. Once shutdown, the fission product activity decays to a low level in a matter of days. The level in the polyethylene is low enough to allow a fuel disk to be handled without shielding 24 hours after shutdown. All fission products generated by the reactor are contained within the fuel disks. Radiation exposure during operations is reduced to acceptable levels by water, lead and concrete shielding surrounding the core.

Secondary sources of radiation associated with the ISU AGN-201M reactor facility are activated foils and samples. Radiation exposure from these experimental sources, and activated experimental components is controlled through the use of operating procedures using the normal protective measures of time, distance and shielding.

11.1.6 Routine Monitoring

The ISU AGN-201M reactor console contains one fixed position radiation area monitor (RAM). The RAM has an alarm setpoint with an audible warning. It is calibrated to alarm at 10mR/hr. In addition there are portable beta-gamma detectors (Ion chamber and Geiger-Müller) available to operations personnel. All of these detectors are maintained and calibrated according to requirements contained in the ISU Radiation Safety Policy Manual.

Radiation surveys are performed according to the procedures within the ISU Radiation Safety Policy Manual. This manual also specifies frequency of personal surveys, laboratory surveys by the user and laboratory surveys by the TSO.

ISU uses a National Voluntary Laboratory Accreditation Program (NVLAP) accredited dosimetry service for external radiation monitoring. Dosimeters are exchanged quarterly and results reviewed during quarterly RSC meetings to ensure proper oversight of the ALARA program. ISU uses two types of thermo-luminescent devices (TLDs) that measure dose due to (1) photons, electrons, and neutrons; and (2) photons and electrons. The Type 1 dosimeter (TLD 760) is issued to all radiation users associated with the AGN-201M reactor. The reactor facility also maintains pocket dosimeters to monitor dose rates to visitors.

11.2 Radioactive Waste Generation and Management

Because the low power level, and resultant low neutron flux levels, there has been negligible generation of radioactive waste (airborne, liquid or solid) at the ISU AGN-201M reactor. For most research reactors, the generation of radioisotopes Ar⁴¹ and N¹⁶ are the most significant radioactive waste products. However, due to the design and low power levels associated with the AGN-201M reactor, even these radioisotopes are not produced in sufficient quantity to constitute a significant radiological hazard.

Materials activated in the experimental facilities are generally short half-life nuclides for student laboratory use. The facility maintains records of radionuclides produced by the reactor. Transfers of radioactive materials to other licensees is rare. When transfers are done, they are conducted according to appropriate state, and federal regulations. All radioactive waste is transferred to TSO for disposal, according to the procedures within the ISU Radiation Safety Policy Manual.

11.3 Conclusions

The NRC staff reviewed Idaho State University Radiation Safety Policy Manual along with the operational history of the AGN-201M reactor and concludes that any airborne, radioactivity release from the operating reactor at 5 W(t) will be insignificant. The staff also concludes that the waste management activities at the ISU have been, and are expected to continue to be, conducted in compliance with 10 CFR 20 consistent with the guidance in ANSI/ANS 15.11-1993, *Radiation Protection at Research Reactor Facilities* and ALARA principles.

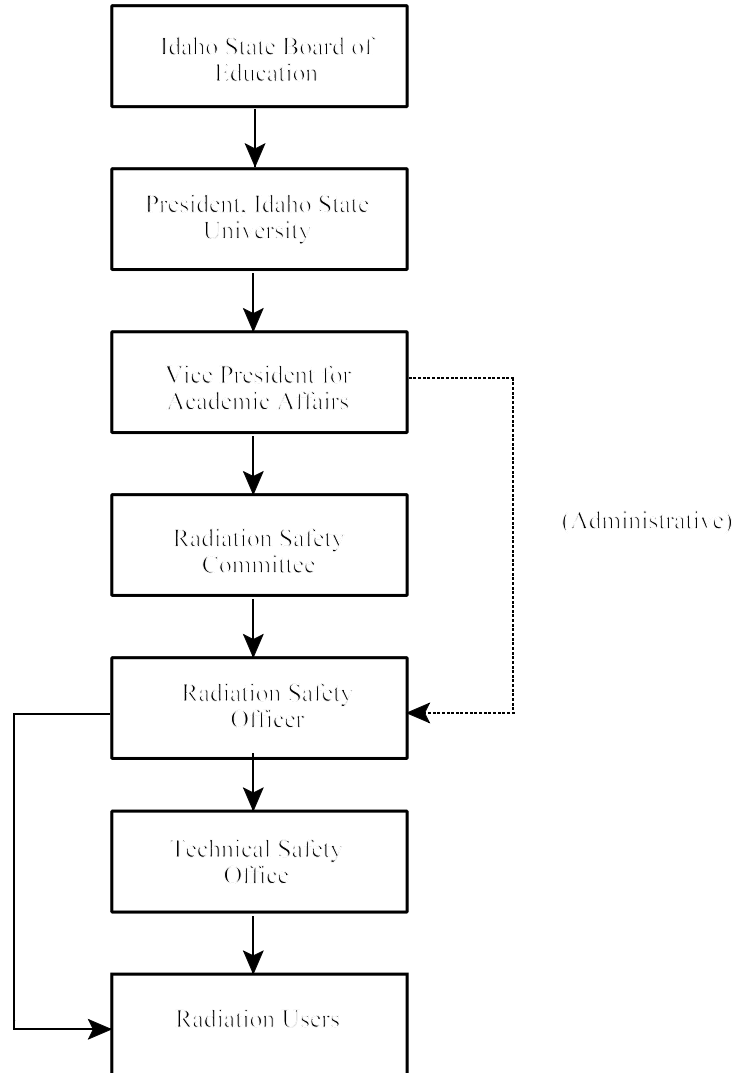

Figure 11.1 Idaho State University Radiation Protection Organizational Chart

12 CONDUCT OF OPERATIONS

12.1 Overall Organization

The ISU AGN-201M reactor facility organizational chart is shown in figure 1 to this chapter.

12.2 Training

Operator training is done by in-house personnel. The licensee submitted a revised Operator Requalification Program with the license renewal package. The NRC has reviewed the program and found that it meets all applicable regulations (10 CFR 50.54 (i-l) and appendix A of 10 CFR 55) and is consistent with guidance contained in ANSI/ANS 15.4, 1888. The revised program will be approved as part of this license renewal.

12.3 Operational Review and Audits

ISU has established two review committees: the Radiation Safety Committee and the Reactor Safety Committee. The Radiation Safety Committee has overall responsibility for advising the University administration and the Radiation Safety Officer on all matters concerning radiological safety at all University facilities.

The Reactor Safety Committee is responsible for, but not limited to: reviewing and approving safety standards associated with the use of the reactor facility; reviewing and approving all proposed experiments and procedures and changes thereto; reviewing and approving all modifications to the reactor facility which might affect its safe operation; determining whether proposed experiments, procedures, or modifications meet the requirements contained in 10 CFR 50.59, and are in accordance with these Technical Specifications; conducting periodic audits of procedures, reactor operations and maintenance, equipment performance, and records; review all reportable occurrences and violations of these Technical Specifications, evaluating the causes of such events and the corrective action taken and recommending measures to prevent reoccurrence; reporting all their findings and recommendations to prevent reoccurrence; and, reporting all their findings and recommendations concerning the reactor facility to the Reactor Administrator.

12.4 Procedures

The licensee has developed a comprehensive set of written operating procedures for all aspects of reactor facility operation. These procedures address, but are not limited to: (1) reactor operation, including startup and shutdown; fuel movements; (2) surveillance checks, calibrations, and inspections required by Technical Specifications (TSs); (3) administrative controls for operations; and (4) maintenance and conduct of experiments.

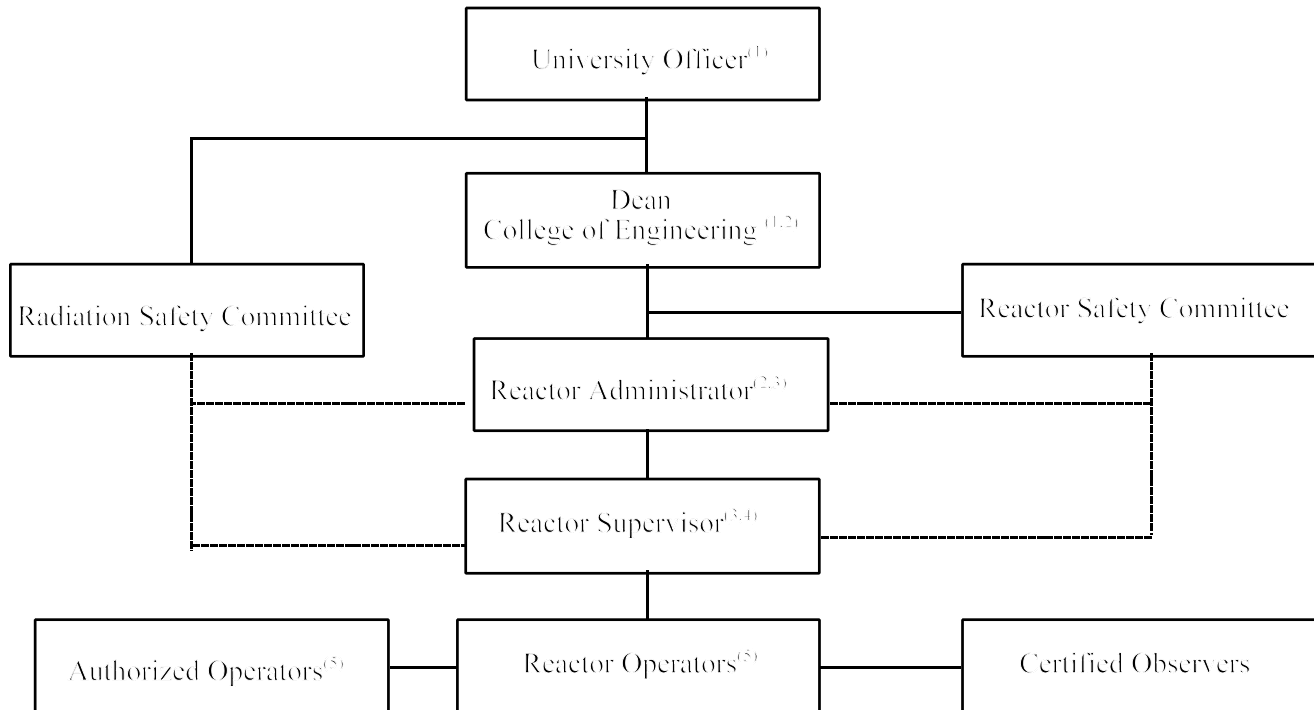

⁽¹⁾ University Officer and Dean of the College of Engineering may be same individual.
⁽²⁾ Dean of the College of Engineering and Reactor Administrator may be same individual.
⁽³⁾ Reactor Administrator and Reactor Supervisor may be same individual.
⁽⁴⁾ Requires NRC Senior Reactor Operators License.
⁽⁵⁾ Requires NRC Reactor Operators License except where exempt per 10 CFR 55.13.

Figure 12.1 AGN-201M Reactor Administrative Organizational Chart

Changes to these procedures are governed by TS 6.6. Substantive changes to these procedures require review by the Reactor Safety Committee, and approval by the Reactor Administrator. Temporary procedures which do not change the intent of previously approved procedures and which do not involve any of the criteria listed in 10 CFR 50.59 (c) may be employed upon approval by the Reactor Supervisor.

12.5 Emergency Planning

The licensee submitted a revised Emergency Plan with the license renewal package. The NRC has reviewed the plan and found that it meets all applicable regulations (Appendix E of 10 CFR 55). The revised program will be approved as part of this license renewal.

12.6 Physical Security Plan

The licensee submitted a revised Physical Security Plan with the license renewal package. The NRC has reviewed the plan, found that it meets all applicable regulations (10 CFR 54.34(c) and 73.40(a)) and finds the plan acceptable. The revised plan will be approved as part of this license renewal. The Physical Security Plan and the staff's evaluation are withheld from public disclosure under 10 CFR 2.790(d)(1).

12.7 Conclusions

The NRC staff concludes that the licensee has sufficient experience, management and oversight structure, and procedures to provide reasonable assurance that the ISU AGN-201M reactor will continue to be managed in a way that will cause no significant radiological risk to the health and safety of the public.

13 ACCIDENT ANALYSES

NUREG-1537, "Guidelines for Preparing and Reviewing Applications for the Licensing of Non-Power Reactors" specifies accidents for consideration. The licensee considered the potential consequences on the reactor fuel and on the radiological health and safety of the licensee's staff, and the public for the Maximum Hypothetical Accident (licensee terminology: Maximum Credible Reactivity Accident) and the loss of Shielding Water from the AGN shield tank.

13.1 Maximum Hypothetical Accident (MHA)

The licensee determined that the MHA for the ISU AGN-201M research reactor is the insertion of fissionable material (U^{235}) into the reactor core via the glory hole. The original argument was put forth by the reactor designer (Aerojet General Nucleonics) and was published in the Hazards Summary Report for the AGN-201 reactor in August 1957. The analysis made the following assumptions:

- (1) At time zero (t_0), a 2% step increase in reactivity is inserted into the reactor at full power operation.
- (2) The energy in the core at t_0 is negligible in comparison with the energy liberated during the ensuing excursion.
- (3) No heat is removed from the core during the excursion.

During the MHA, the licensee calculates that the reactor would reach a peak power of approximately 170 Megawatts, then rapidly decreases to approximately 800 kilowatts, then the power will slowly decay all within a window of 0.3 seconds. Also within these 300 milliseconds, the total energy released from the core is calculated to be 5.8 Megajoules. The maximum temperature in the core (other than the core fuse) is calculated to be 120°C. The calculated dose to an individual at the surface of the concrete shield would be 3.2 rem. The temperature within the fuse would be greater because of its position in the middle of the core and the higher density of fuel within it. The fuse is expected to melt and add 5% negative reactivity shutting down the reactor, and preventing recurrence of the accident.

The prediction that only the thermal fuse would melt is reasonable because the melting temperature for the polyethylene in the fuel matrix is 200°C. Therefore the assumption that fission products would be contained in the fuel, and primary and secondary containers is also reasonable. There would be some gaseous fission product release from the melted fuse, but this is considered a small amount (\approx 2 millirem), and as such would not be detectable at the site boundary.

13.2 Loss of Shield Tank Water

If all water is lost in the shielding tank while the reactor is operating, it is estimated that radiation levels due to gammas would increase by a factor of six, and radiation levels due to fast neutrons would increase by a factor of 11. At normal full power operation, this would be approximately 7 mrem/hr for gamma rays and 170 mrem/hr for fast neutrons at the concrete shield boundary. This level of radiation would trip the high level radiation alarm mounted on the reactor console.

13.3 Conclusions

The NRC staff concludes that even under the least favorable atmospheric conditions, the MHA will not result in occupational radiation exposure of the licensee staff or radiation exposure of the general public in excess of 10 CFR 20 limits. In addition, the staff concludes that for a loss of shielding water accident, the TS required and procedural controls provide reasonable assurance that the risk to reactor personnel and the general public is minimal.

14 TECHNICAL SPECIFICATIONS

The licensee submitted new technical specifications as part of its license renewal. These TSs define certain features, characteristics and conditions governing the operation of the ISU AGN-201M research reactor and are explicitly included in the renewal license as Appendix A. The staff reviewed the format and content of the TSs using the guidance within ANSI/ANS 15.1-1990, *The Development of Technical Specifications for Research Reactors* and the guidance in applicable sections of NUREG 1537, *Guidelines for Preparing and Reviewing Applications for the Licensing of Non-Power Reactors*, dated 1996.

The NRC staff finds the submitted TSs to be acceptable and concludes that normal plant operation within the limits of the TSs will not result in offsite radiation exposures in excess of the limits specified in 10 CFR Part 20. Furthermore, the limiting conditions for operation and surveillance requirements will limit the likelihood of malfunctions and mitigate the consequences to the staff, public and environment in regard to potential accidents.

15 FINANCIAL QUALIFICATIONS

The ISU AGN-201M reactor facility is owned and operated by a state educational institute in support of its role in education and research.

The staff reviewed the financial status of the licensee and concludes that the necessary funds will be made available to support continued operations and, when necessary, to shut down the facility and carry out decommissioning activities. The licensee's financial status is in accordance with 10 CFR 50.33(f). Therefore the staff concludes that ISU's financial qualifications are acceptable for continued operations of the AGN-201M research reactor facility.

16 PRIOR UTILIZATION AND AGING

16.1 Prior Utilization

The staff reviewed past operation of the ISU AGN-201M reactor with special emphasis on degradation of safety components and systems. The review showed that the reactor staff performed regular preventative maintenance, corrective maintenance, and replaced components when required. The staff noted some equipment malfunctions, but determined that most of these malfunctions were random one-of-a-kind incidents. There is no indication of significant degradation of the instrumentation, and there is strong evidence based on past experience and TS requirements, that any future degradation will be met with prompt remedial action by the AGN-201M reactor staff.

This reactor operates at relatively low flux and temperature levels compared to other NRC licensed reactors. Because of this aging effects due to both temperature and neutron flux are considered to be insignificant.

16.2 Conclusion

The staff concludes that there has been no significant degradation of equipment and that facility management will continue to maintain and operate the reactor so that there is no significant increase in the radiological risk to facility staff, the public or the environment.

17 CONCLUSIONS

On the basis of its evaluation of the application as set forth in the previous chapters of this SER, the NRC staff has reached the following conclusions:

- The application, as supplemented, filed by the Idaho State University for renewal of the operating license for their AGN-201M research reactor complies with the requirements of the Atomic Energy Act of 1954, as amended (the Act), as well as the Commission's regulations set forth in 10 CFR Chapter I.
- There is reasonable assurance that the facility will be operated in conformance with the application (as amended), as well as the provisions of the Act and the rules and regulations of the Commission.
- There is reasonable assurance that (a) the activities authorized by the operating license will be conducted without endangering the health and safety of the public and (b) such activities will be conducted in compliance with the Commission's regulations as set forth in 10 CFR Chapter I.
- The licensee is technically and financially qualified to engage in the activities authorized by the license in accordance with the Commission's regulations as set forth in 10 CFR Chapter I.
- The renewal of this license will not be inimical to the common defense and security or to the health and safety of the public .